

Application

Used to convert a direct-current input signal into a pneumatic output signal for measuring and control tasks · Particularly suitable as intermediate element between electric measuring devices and pneumatic controllers or between electric control devices and pneumatic control valves

Ex certified 

These converters are designed for use in all kinds of industrial applications, especially in the field of process engineering.

The converters accept a load-independent 4 to 20 mA or 0 to 20 mA direct current input signal which they convert into a pneumatic output signal.

Wide output pressure ranges can be selected for the Type 6111 i/p Converter by installing various converter modules (see Technical data). The maximum output pressure that can be achieved is 8 bar.

Special features

- Wide selection of measuring ranges
- High output pressures up to 8 bar
- Easy replacement of i/p module
- Zero reset at specific mA value when switch-off electronics are activated
- Operation possible without an upstream pressure regulator
- Version designed as rail-mounting unit with plastic housing or as field unit for offshore applications in a stainless steel enclosure
- Supply air manifold for rail-mounting units available as accessories for 3, 4, 5 and 6 converter units (Fig. 4)

Versions

- Type 6111 as a rail-mounting unit (Fig. 1) · Mounted on a top-hat rail
- Type 6111 as a field unit for offshore applications (Fig. 2) Mounted using a bracket

Special versions (on request)

- 0/2 to 10 V input signal with Type 6151 module
- Electric connection with an angle connector according to DIN EN 175301-803 A
- AS-Interface connection over Type 6150 module
- Initial pressure of 0 bar possible

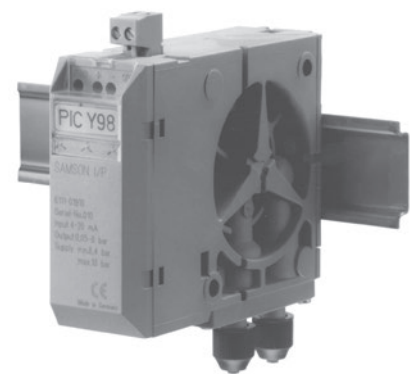

Fig. 1: Type 6111 i/p Converter, rail-mounting unit



Fig. 2: Type 6111, field unit for offshore applications

Principle of operation (Fig. 3)

The electropneumatic converter consists of an i/p converter module, which operates according to the force-balance principle, and a downstream volume booster.

When operated, the supplied direct current (4) flows through the plunger coil (2) located in the field of a permanent magnet (3). At the balance beam (1), the force of the plunger coil, which is in proportion to the current, is balanced against the force of the dynamic backpressure. The backpressure is produced on the flapper plate (6) by the air jet leaving the nozzle (7).

The nozzle is supplied with air from the pneumatic output (36). With an input signal of 0 mA, an output pressure of approximately 50 to 80 mbar is already issued due to the offset spring.

The supply air (9) flows in the lower diaphragm chamber, and a certain amount flows to the output. When the current increases, the flapper moves closer to the nozzle. The force of the resulting backpressure p_K pushes both the diaphragm (5) and sleeve (8) downwards, allowing additional air to enter the chamber. The passing air volume increases until the forces on the diaphragm obtain a state of equilibrium. When the current decreases, this action is reversed. The backpressure created by the nozzle and flapper decreases, and the diaphragm is pressed upwards. In this process, it releases the sleeve, if applicable, and opens the vent (11) until the forces on the diaphragm are balanced again.

Converter modules with an input signal range from 4 to 20 mA have a slide switch which activates the switch-off electronics. The electronics cause the pneumatic output to be vented up to approx. 100 mbar when the input signal falls below ± 4.08 mA tolerance. In this way, the tight shut-off function of a valve can be guaranteed.

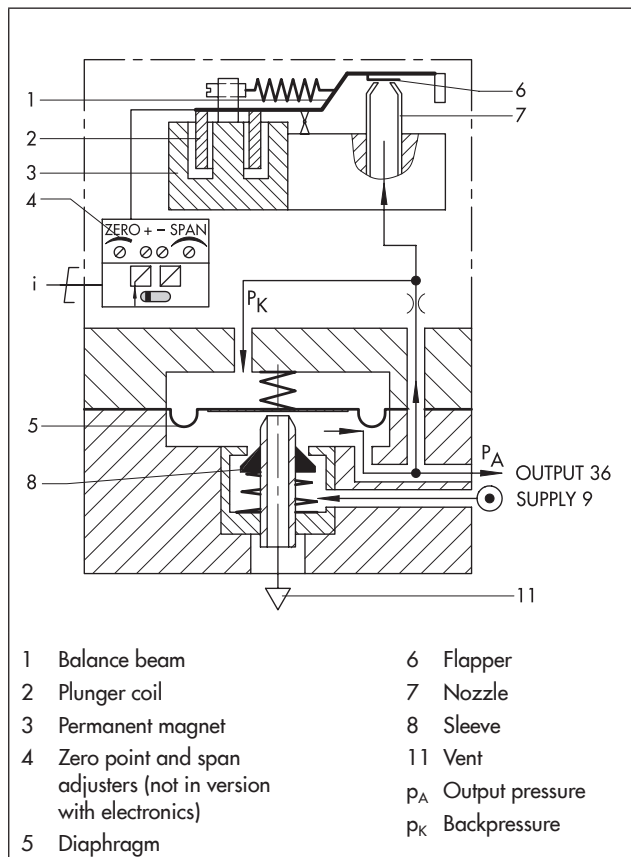

Fig. 3: Functional drawing of Type 6111



Fig. 4: Supply air manifold for Type 6111

Table 1: Technical data

Type	Type 6111	Rail-mounting unit	Field unit
Explosion protection		⊕ II 2 G Ex ia IIC T6	⊕ II 3 G Ex nA IIC T6
Input		4 to 20 mA (0 to 20 mA on request), for split-range: 4 to 12 mA or 12 to 20 mA, other signals on request	
Load	Standard Explosion-protected version Version without switch-off electronics:	≤ 6 V (corresponding to 300 Ω at 20 mA) 7 V (corresponding to 350 Ω at 20 mA) ≤ 4 V (corresponding to 200 Ω at 20 mA)	
Output	with Type 6112 i/p Module	0.2 to 1 bar (3 to 15 psi) (standard range) 0.4 to 2 bar (6 to 30 psi) (standard range) Special ranges adjustable at the factory to meet customer specifications	
	Module A	Initial value ²⁾ 0.1 to 0.4 bar	Span Δp 0.75 to 1.0 bar
	Module B	0.1 to 0.4 bar	1.0 to 1.35 bar
	Module C	0.1 to 0.4 bar	1.35 to 1.81 bar
	Module D	0.1 to 0.8 bar	1.81 to 2.44 bar
	Module E	0.1 to 0.8 bar	2.44 to 3.28 bar
	Module F	0.1 to 0.8 bar	3.28 to 4.42 bar
	Module G	0.1 to 1.2 bar	4.42 to 5.94 bar
	Module H	0.1 to 1.2 bar	5.94 to 8.0 bar ¹⁾
	Max. air output capacity ³⁾	2.0 m ³ /h at an output of 0.6 bar (0.2 to 1.0 bar) 2.5 m ³ /h at an output of 1.2 bar (0.4 to 2.0 bar) 8.5 m ³ /h at an output of 5.0 bar (0.1 to 8.0 bar)	
Supply air		At least 0.4 bar above the upper signal pressure range value, max. 10 bar without supply pressure regulator	
	Air quality acc. to ISO 8573-1: 2001	Max. particle size and density: Class 4 · Oil content: Class 3 · Pressure dew point: Class 3 or at least 10 K below the lowest ambient temperature to be expected	
	Power consumption	0.08 m ³ /h at 1.4 bar · 0.1 m ³ /h at 2.4 bar · Max. 0.26 m ³ /h at 10 bar	
Characteristic		Characteristic: Output linear to input	
	Hysteresis	≤ 0.3 % of final value	
	Deviation from terminal-based conformity	≤ 1 % of upper range value (for upper range values up to 5 bar); more exact values on request · ≤ 1.5 % of upper range value (for upper range values above 5 bar)	
	Effect in % of the upper range value	Supply air: < 0.1 %/0.1 bar	
		Alternating load, supply air failure, interruption of the input current: < 0.3 % Ambient temperature: lower range value < 0.03 %/K, span < 0.03 %/K	
Dynamic response		At an output of 0.2 to 1 bar	
	Limiting frequency	5.3 Hz	
	Phase shift	-130°	
Variable position		Max. 3.5 % depending on mounting position: e.g. ± 1 % when mounted horizontally	
Ambient conditions, degree of protection, weight			
	Storage temperature	-40 to 70 °C	
	Ambient temperature	-20 to 70 °C	
	Degree of protection	IP 20	IP 65
	Compliance	CE . EAC	
	Weight	Approx. 0.35 kg	1.9 kg
Materials			
	Housing	Glass-fiber-reinforced polyamide	Stainless steel 1.4581 Bracket 1.4301

¹⁾ Max. possible output pressure 8 bar

²⁾ Initial value raised up to 3.0 bar (special version)

³⁾ Measured with 2 m hose with 4 mm inside diameter

Summary of explosion protection approvals

Version	Type of approval	Certificate number	Date	Type of protection	Comments
6111-1	EC Type Examination Certificate	PTB 01 ATEX 2174	2001-11-26	⊕ II 2 G Ex ia IIC T6	-
6111-8	Statement of Conformity	PTB 02 ATEX 2013 X	2001-11-26	⊕ II 3 G Ex nA II T6	-

The test certificates are included in the mounting and operating instructions or are available on request.

Electrical connection

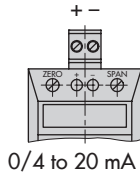

Fig. 5: Terminal assignment · Input signal

Installation

- **Rail-mounting unit** for mounting on a top hat rail according to DIN EN 60715, 35 mm wide
 - Wall mounting possible, using holes with \varnothing 5.5 mm
 - Air connections (supply air and output): hose connection suitable for hose (4 mm inside diameter and 6 mm outside diameter) as standard; also available as ports with $\frac{1}{8}$ NPT, G $\frac{1}{8}$ or M5 female thread
 - Mounting on supply air manifold possible
 - Electrical connection: plug-in two-pole terminals for 0.5 to 2.5 mm² wires
- **Field units** for offshore applications for mounting using a bracket
 - Mounting bracket (stainless steel), item number: 1400-7432 (included in the scope of delivery)
 - Pneumatic connections: $\frac{1}{4}$ NPT
 - Electrical connection: M20 x 1.5

Dimensions · Type 6111 as rail-mounting unit and field unit · Dimensions in mm

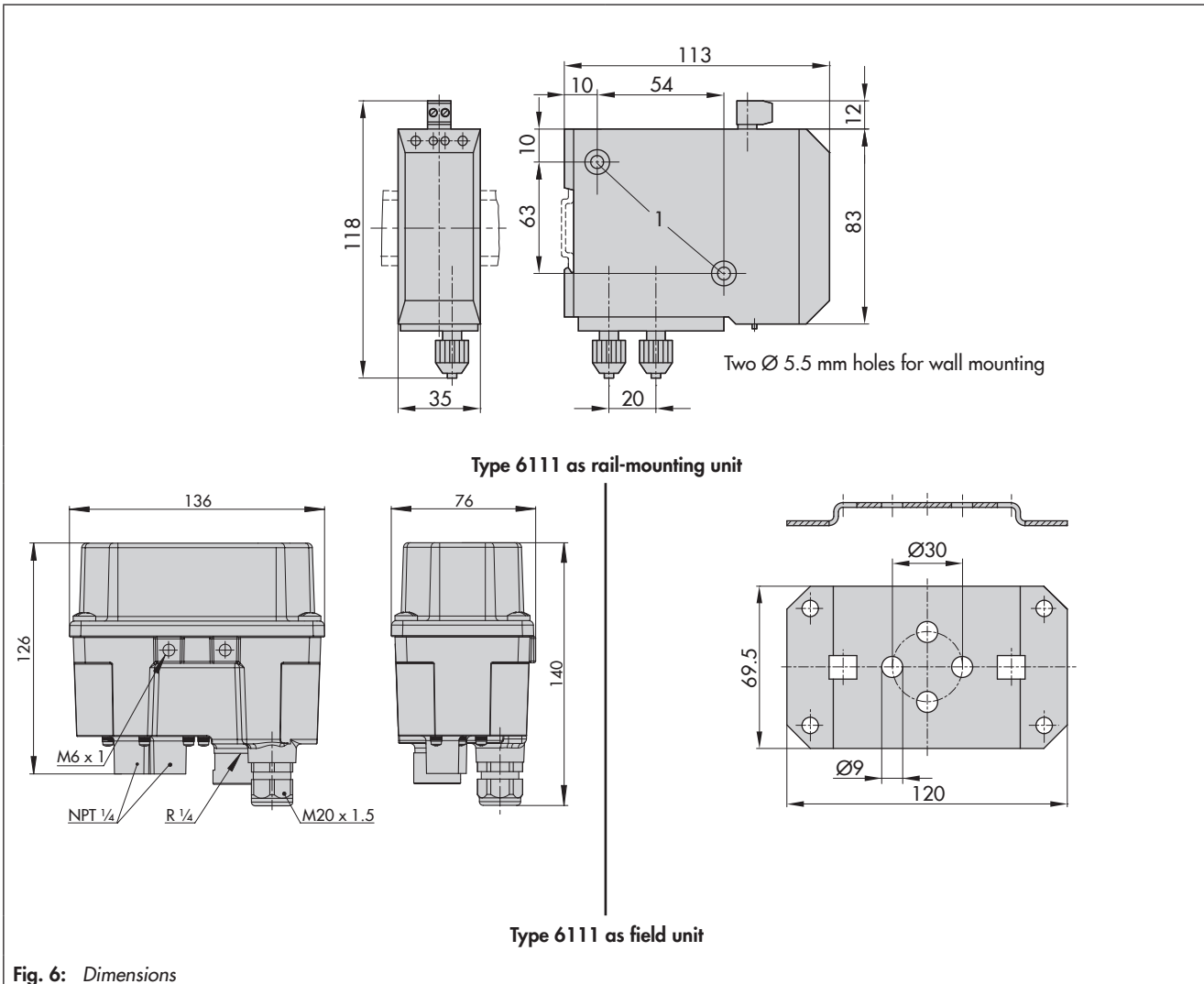

Fig. 6: Dimensions

Ordering data

Article code		Type 6111-											
Explosion protection	Without	0											
	⊕ II 2 G Ex ia IIC T6 acc. to ATEX	1											
	⊕ II 3 G Ex nA II T6 acc. to ATEX ⁴⁾	8											
Housing	For rail mounting, 35 mm top-hat rail (DIN EN 60715)	0											
	Field enclosure in stainless steel 1.4581	1											
i/p converter module	Type 6109		1										
	Type 6112		2										
Input	4 to 20 mA with switch-off electronics			0	1								
	0 to 20 mA without switch-off electronics ¹⁾		2	0	2								
	4 to 12 mA with switch-off electronics		2	0	3								
	12 to 20 mA with switch-off electronics		2	0	4								
Volume booster	I (output from 0.1 bar/3 psi)					1							
	II (output from 0.0 bar/0 psi) ²⁾		2			2							
Output	0.2 to 1.0 bar					1	0	1					
	3 to 15 psi					1	0	2					
	0.4 to 2.0 bar		2			1	0	3					
	6 to 30 psi		2			1	0	4					
	Special ranges ^{3),5)}		2				1	1					
	Initial value 0.1 to 0.4 bar, span Δp 1.00 to 1.35 bar		2				1	2					
	Initial value 0.1 to 0.4 bar, span Δp 1.35 to 1.81 bar		2				1	3					
	Initial value 0.1 to 0.8 bar, span Δp 1.81 to 2.44 bar		2				1	4					
	Initial value 0.1 to 0.8 bar, span Δp 2.44 to 3.28 bar		2				1	5					
	Initial value 0.1 to 0.8 bar, span Δp 3.28 to 4.42 bar		2				1	6					
Initial value 0.1 to 1.2 bar, span Δp 4.42 to 5.94 bar		2				1	7						
Initial value 0.1 to 1.2 bar, span Δp 5.94 to 8.00 bar		2				1	8						
Operating direction	Increasing/increasing								1				
	Increasing/decreasing		2						2				
Pneumatic connection	Hose connection for 4 mm inside diameter and 6 mm outside diameter (M10 x 1 hose screw fittings)	0								0			
	1/8-27 NPT female thread	0								1			
	ISO-228/G 1/8 female thread	0								2			
	M5 female thread	0								3			
	1/4-18 NPT	1								4			
	Electrical connection	Terminals for 0.5 to 2.5 mm ² wires	0									1	
	Angle connector acc. to DIN EN 175301-803	0									2		
	M20 x 1.5	1									3		
Degree of protection	IP 20	0										1	
	IP 65	1										2	
Temperature	T _{min} ≥ -20 °C												0
Special version	Without												0 0 0

¹⁾ Without switch-off electronics and without potentiometer for zero point and explosion-protected device without potentiometer for span correction

²⁾ A relatively stable supply air network is required for the special version with volume booster II

³⁾ Specify setting range, e.g. set to 0.1 to 4 bar; output pressure max. 8 bar, supply air 10 bar

⁴⁾ The rail-mounting unit must be installed in an enclosure with minimum degree of protection IP 54 for Ex nA version.

⁵⁾ Initial value raised up to 3.0 bar (special version 300 and 301)