

PROCO

The Expansion Joint and Check Valve People



The PROCO Series 700 ProFlex™ Rubber Check Valves are a cost effective way to control back pressures from sewage treatment plants, outfalls and tidal operations. They are a fully passive flow device requiring neither maintenance nor any outside sources of power or manual assistance to operate.

The PROCO Series 700 ProFlex™ Check valves are offered as direct replacements for ineffective and maintenance ridden flap type check valves, commonly known to seize, rust and bind in unwanted positions. Unlike flap type valves, the ProFlex™ rubber check valves will handle large obstructions without jamming or having swing gates binding open. Specify the PROCO Series 700 ProFlex™ rubber check valves to provide backflow protection from (1) Sewage slurries, (2) Outfalls to ocean fronts from heavy rainfall activity, (3) Prevention from land erosion due to back flow conditions, (4) Protection from saltwater to fresh water ponds and catch basins and numerous other water based applications. Our history in the manufacture of rubber piping products dates back to 1930. When an engineered solution is needed to solve a piping or backflow problem, call PROCO.

The Proco Series 700 ProFlex™ Rubber Check Valves are available in the following styles:

- **Style 710: Flanged:** Designed to bolt directly to existing flanges or new installations, flanges are drilled to ANSI 125/150# standard. Other drilling standards are also available upon request. The style 710 can be installed in either vertical or horizontal applications.
- **Style 710TT: Flanged Blending System Valves:** The Patented Torsionally twisted valve is designed to bolt directly on existing or any new installations. This valve is supplied to ensure proper mixing in potable water reservoirs and tanks. The torsional design ensures quick and accurate blending which provides a properly blended volume of potable water.
- The Hydraulic Blending Analysis provided by Proco (based on CFD and engineered scale modeling) supplies the contractor/end user with strategic location points for each valve. All valves will be ANSI/NSF-61 certified.
- **Style 711/731 Flanged/Slip-on Slope Bottom Check Valves:** Designed for installation on pre-existing or new pipe lines such as manholes, outfalls, vaults, where the outfall invert of the pipe is close to the floor of the manhole or outfall. Can be engineered into the pipe layout with little concern for outfall clearance due to its "low slope" design.

- **Style 720: Flanged In-line:** Designed to fit directly inside of an existing pipe. Supplied with a flat face rubber flange which allows installation between existing pipe flanges eliminating the requirement for a valve body. Flanges are drilled to ANSI 125/150# standard. Other drilling standards are also available upon request.
- **Style 730: Sleeve Type:** Designed to easily slip over an existing pipe, and is affixed with heavy-duty stainless steel clamps. Can be installed in either a vertical or horizontal application.
- **Style 730M: Molded Type:** Molded Type : A economical engineered valve, available in smaller pipe diameter ranging from 3/4" -6" nominal sch 40 pipe size. Designed to prevent odors and low back pressures from seeping back up the stream channel. Supplied with stainless steel gear clamps.
- **Style 730CBD: Coarse Bubble Diffusers:** Designed to provide excellent coarse bubble diffusion in settling ponds, tanks, reservoirs, Supplied with a stainless steel Hex nipple, PVC adapter and variable orifices, makes this the valve of choice.
- **Style 740: Slip In-Inline:** Designed to slip directly inside of an existing pipe. Supplied with a stainless steel expandable clamp to secure it in place.
- **Style 750: Jacketed:** Designed with a full metal enclosure which allows easy installation in existing piping systems. Utilizes the Style 710 as the check valve.
- **Style 770/780: Wafer Style:** Designed with a metal or plastic orifice plate and a rubber disk , this valve is an ideal valve to provide high back pressure capability on clean water applications.
- **Style 790: Low Headloss In-Line:** Designed as an all one piece constructed valve, the Style 790 is one of lowest headloss valves on the market. A passive flow device ensuring no delamination.

ELASTOMERS: All of the PROCO Series 700 ProFlex™ Rubber Check Valves are available in a various selection of elastomers including ANSI/NSF-61 certified product under UL Certification #MH47689. The PROCO Series 700 ProFlex™ Rubber Check Valves will not freeze or deform and function solely on the inlet and back pressures which will be present in each application.

Each valve is carefully constructed using the finest of engineered materials and some of the most experienced rubber technicians in the industry. All check valves are engineered in precise detail to ensure proper operation and will provide years of unhindered operation and trouble free service.

Benefits of the PROCO Series 700 ProFlex™ Rubber Check Valves:

- All rubber construction resists abrasive slurries
- Barnacle resistant Neoprene is standard construction, with ANSI/NSF-61 certified valves also available
- Very quiet operation with no water hammer
- Its unique design prevents backflow
- Negligible maintenance and energy costs
- Will not warp or freeze
- Quick interchange with any flap type check valve
- Available in sizes 1" - 96"
- Available with special I.D to suit concrete pipe

Table 1: Available Materials • Temperatures

For Specific Elastomer Recommendations, See: PROCO™ "Chemical To Elastomer Guide"

PROCO Material Codes	Cover ³ Elastomer	Tube Elastomer	Maximum Operating Temp. °F (°C)
BB	Chlorobutyl	Chlorobutyl	250° (121°)
EE	EPDM	EPDM	250° (121°)
NH	Neoprene	CSM	212° (100°)
NN	Neoprene	Neoprene	225° (107°)
NN-NSF61 ²	Neoprene	Neoprene	225° (107°)
PP	Nitrile	Nitrile	212° (100°)
NR	Neoprene	Natural Rubber	180° (82°)

Notes: ProFlex™ is a trademark of PROCO Products, Inc.
 All products are reinforced with polyester tire cord.
 1. Styles with Neoprene covers meet all requirements of U.S.C.G.
 2. NN-NSF/61 UL Classified Water Quality
 3. Other materials available. Please contact Proco Products



Proco Style **710**

ProFlex™ Flanged Rubber Check Valves



Proco Style **710TT**

ProFlex™ ANSI/NSF-61 Flanged Blending System Valves

Covered by U.S. Patent No. 11,396,951



Proco Style **711**

ProFlex™ Flanged Slope Bottom Check Valves

Covered by US Patent Number 11,221,081



Proco Style **720**

ProFlex™ In-line Flanged Rubber Check Valves



Proco Style **730**

ProFlex™ Slip-on Rubber Check Valves



Proco Style **730M**

ProFlex™ Low Pressure Molded Rubber Check Valves



Proco Style **730CBD**

ProFlex™ Coarse Bubble Diffusers



Proco Style **731**

ProFlex™ Slip-on Slope Bottom Check Valves

Covered by US Patent Number 11,221,081



Proco Style **740**

ProFlex™ Slip-in Style In-line Rubber Check Valves



Proco Style **750**

ProFlex™ Jacketed In-line Flanged Rubber Check Valves

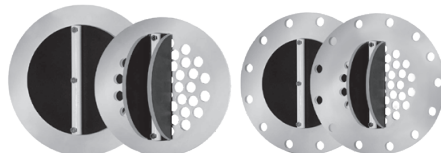

Proco Style **770/780**

ProFlex™ Wafer Style In-line Flanged Rubber Check Valves



Proco Style **790**

ProFlex™ Low Headloss In-line Rubber Check Valves

**PROCO
STYLE**

710

ProFlex™ Flanged Rubber Check Valves



The **ProFlex™ 710** is a full port, concentric design Rubber Duckbill Check Valve. The ProFlex™ 710 Rubber Duckbill Check Valves can be supplied with many different flange drilling configurations, including square or rectangular flanges to suit problematic sluice gate or flap gate replacements.

The unique advantage to this valve is its very low 1" - 2" (25mm-50mm) cracking pressure and is often referred to as the lowest head loss valve in the industry.

All **ProFlex™ 710** Rubber Duckbill Check Valves are supplied with 316ss retaining rings and can also be supplied with 304ss, Galvanized, Epoxy coated, FRP material if required or Encapsulated Steel Rubber Flange.

The **ProFlex™ 710** Rubber Duckbill Check Valves come standard with ANSI 125/150 flange drilling and can also be supplied with DIN, JIS, BS or AS flange patterns.

All **ProFlex™ 710** Rubber Duckbill Check Valves are also available from inventory in a Standard Rated (SR) design, and can also be custom manufactured to meet specific head and back pressures.

For higher pressure/vacuum requirements, the **ProFlex™ 710** Rubber Duckbill Check Valves can also be manufactured using a unique Internal Vacuum Supports (IVS) design which is homogeneous to the inner reinforced layers of the valve allowing a full flow with no obstructions and yet providing excellent anti-inversion features.

Style 710

Diameter		Standard Valve Dimensions				Standard Drilling ANSI 125/150#							Approx. Weight	
		Length		Duckbill Height		Flange O.D.		Bolt Circle Diameter		No. of Holes	Size of Holes			
in.	mm	in.	mm	in.	mm	in.	mm	in.	mm			in.	mm	lbs
1	25	5.1	130	2.4	62	4.25	108	3.125	79	4	0.625	15.9	3	1.5
1.5	40	6.0	153	3.2	82	5.00	127	3.875	98	4	0.625	15.9	3	1.6
2	50	6.6	168	3.8	97	6.00	152	4.75	121	4	0.750	19.1	4	1.7
2.5	65	7.4	188	4.8	122	7.00	178	5.50	140	4	0.750	19.1	5	2.4
3	75	8.5	216	5.6	142	7.50	191	6.00	152	4	0.750	19.1	6	2.7
4	100	10.5	267	6.9	174	9.00	229	7.50	191	8	0.750	19.1	9	3.9
5	125	11.5	293	9.0	228	10.00	254	8.50	216	8	0.875	22.2	14	6.5
6	150	12.8	326	10.6	268	11.00	279	9.50	241	8	0.875	22.2	15	6.7
8	200	15.0	380	13.7	348	13.50	343	11.75	298	8	0.875	22.2	24	10.7
10	250	17.9	455	16.9	428	16.00	406	14.25	362	12	1.000	25.4	31	14.2
12	300	20.3	515	20.6	522	19.00	483	17.00	432	12	1.000	25.4	51	23.1
14	350	22.8	580	23.7	601	21.00	533	18.75	476	12	1.125	28.6	75	34.2
16	400	24.2	615	27.3	693	23.50	597	21.25	540	16	1.125	28.6	93	42.0
18	450	27.2	690	30.6	778	25.00	635	22.75	578	16	1.250	31.8	104	47.1
20	500	28.4	722	32.6	828	27.50	699	25.00	635	20	1.250	31.8	128	58.0
24	600	38.7	983	38.0	964	32.00	813	29.50	749	20	1.375	34.9	203	92.0
28	700	41.1	1045	45.3	1151	36.50	927	34.00	864	28	1.375	34.9	243	110.0
30	750	43.5	1105	49.4	1254	38.75	984	36.00	914	28	1.375	34.9	300	136.3
32	800	44.5	1130	51.0	1295	41.75	1060	38.50	978	28	1.625	41.3	368	167.0
36	900	53.9	1370	59.5	1512	46.00	1168	42.75	1086	32	1.625	41.3	559	253.6
40	1000	53.9	1370	65.8	1671	50.75	1289	47.25	1200	36	1.625	41.3	697	316.3
42	1050	55.7	1415	67.9	1725	53.00	1346	49.50	1257	36	1.625	41.3	744	337.3
48	1200	63.2	1605	76.2	1935	59.50	1511	56.00	1422	44	1.625	41.3	1019	462.3
54	1350	67.9	1725	84.3	2140	66.25	1683	62.75	1594	44	2.000	50.8	1349	611.7
60	1500	73.8	1874	85.4	2170	73.00	1854	69.25	1759	52	2.000	50.8	1598	725.0
64	1600	76.8	1950	89.8	2280	78.00	1981	74.00	1880	52	2.000	50.8	2069	938.5
66	1650	79.9	2030	92.9	2360	80.00	2032	76.00	1930	52	2.000	50.8	2304	1045.2
72	1800	93.2	2367	113.0	2869	86.50	2197	82.50	2096	60	2.000	50.8	2811	1275.1
78	1950	88.0	2234	113.6	2885	93.00	2362	89.00	2261	64	2.125	54.0	3265	1480.8
84	2100	90.2	2290	117.7	2990	99.75	2534	95.50	2426	64	2.25	57.2	3718	1686.5
96	2400	97.2	2470	127.6	3240	113.25	2877	108.50	2756	68	2.5	63.5	4625	2097.9

Notes: Higher back pressures can be provided by using internal vacuum supports and/or engineered Hi-Tensile reinforcement, contact PROCO.

1. Dimensions are approximate and may change due to pipe dimension changes, inlet, back pressures and flow rates.

2. Larger sizes available upon request.

3. Weights are approximate.

Available Elastomers
Neoprene (Barnacle and Algae Resistant),
ANSI/NSF-61, EPDM, Nitrile, Natural
Rubber, CSM and Chlorobutyl.



Detail of the *ProFlex™* Flanged Rubber Check Valve; Style 710

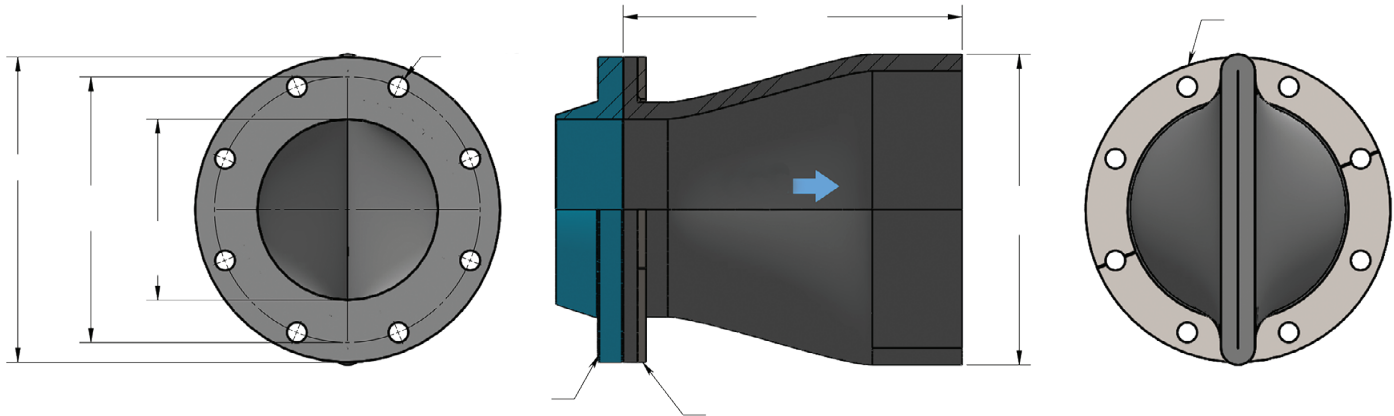

Frequently Asked Questions

ProFlex™ Check Valves

1. Does the ProFlex™ rubber check valve have to be installed in a certain position?

Yes; it should be installed in a vertical position with the bill being the vertical. In zero clearance situations the valve can be rotated up to 30-35 Deg to gain bottom clearance if required.

2. In which degree can the ProFlex™ rubber check valve be installed?

Because the valve is not reliant on any hinges, gates, or weights the ProFlex™ rubber check valve can be installed in any angle from vertical to horizontal.

3. What is "Back Pressure"?

When the ProFlex™ rubber check valve is submerged in a liquid it is subjected to external pressure. It is critical that the maximum depth that the valve will be submerged is specified as this will be considered the maximum back pressure that the valve will be subjected to.

4. What is the cracking pressure to allow the valve to open?

It typically takes 1" to 2" of head pressure over back pressure to crack open all 700 series valve(s). For the Series 790 it will take approximately 33-50% of pipe diameter to flush the valve completely. Contact Proco for further assistance.

5. What back pressures can the ProFlex™ rubber check valve withstand?

Back pressures are in direct relation to the size of the valve, on the smaller diameters it is acceptable to specify up to 200 psi of back pressure and on larger diameters a back pressure limitation would be approximately 12 psi. Each ProFlex™ rubber check valve is manufactured to the exact line pressure, back pressure and flow rates which we require from you for manufacture. Proco can even supply valves up to 650 psi utilizing internal back pressure supports.

6. What are the most common installations?

The ProFlex™ 710 flanged rubber check valve is bolted directly to a head wall replacing an existing flap gate, the ProFlex™ 730 sleeved type rubber check valves are clamped directly to a fabricated flanged nipple or clamped directly to an existing pipe.

7. Can I use the ProFlex™ rubber check valve on potable water applications?

The ProFlex™ rubber check valves are available with an ANSI/NSF-61 certified elastomer. Due to the large demand for clean water and potable applications, this will eliminate the concerns commonly affiliated with contaminants or leaching of elastomers in potable water systems.

8. Can the ProFlex™ rubber check valve be installed on an "out of round" pipe?

Yes, please have the approximate dimensions from 4 different angles to provide proper sizing.

9. Can river currents and ocean waves damage the valves?

In most cases river currents and ocean waves will not damage the ProFlex™ rubber check valves, but if currents or waves in question are of an abnormal nature, it is suggested that side walls or rock pilings are utilized.

10. Can the ProFlex™ rubber check valve be used as a pressure relief valve?

The ProFlex™ rubber check valves have been designed to offer superior service as a backflow preventer and can also be considered as a pressure relief valve. Often used on reservoirs to prevent hydraulic lifting or floating of tanks.

11. Can PROCO make a special design to suit my requirements?

In most instances the ProFlex™ rubber check valve can be fabricated to suit different applications. Contact PROCO for your requirements.

12. What types of elastomer are available?

The ProFlex™ rubber check valves can be manufactured and supplied to withstand almost any type of media. Most commonly supplied is a barnacle and algae resistant Neoprene. Other common elastomers are EPDM, Nitrile, Natural Rubber, and elastomers to meet ANSI/NSF-61 and ANSI/NSF-372 specifications.

13. What types of materials are available for the backing rings and banding clamps?

ProFlex™ rubber check valves are supplied with 316 stainless steel backing rings and 304 stainless steel clamps as a standard. Other materials are available upon request.

14. Can the ProFlex™ 710 be supplied with special flanges or drilling?

Yes, the standard drilling pattern is ANSI 125/150# drilling, other drilling standards such as: ANSI 250/300#, BS-10, DIN NP-10 and DIN NP-16, JIS-5k and JIS-10K are available upon special request.

15. Can I install a ProFlex™ rubber check valve near a residential area?

Yes, one of the unique features of the ProFlex™ rubber check valve is the design of the bill section. While the bill will open and allow passage of fluid when head pressure is present, the bill will close and not allow children or animals to crawl inside when there is no head pressure.

Since the ProFlex™ rubber check valve is manufactured entirely of rubber compounds there is no chance of loud banging which is commonly heard from flap type valves.

16. Can I use a ProFlex™ rubber check valve in winter conditions?

Yes, as in any installation the ProFlex™ rubber check valve will not be hindered by winter or sub-zero installations. If the valve is installed in a running water application the valve will continue to operate satisfactorily, due to the elastomers unique chemical makeup. If unusual circumstances occur the ProFlex™ rubber check valve will freeze without any damage and will return to operation upon thaw.

17. Will the ProFlex™ rubber check valve operate if buried in sand or sediment?

In normal conditions the discharge flow will create a small flow pattern which will then be followed by the flow velocity of the media. This velocity will flush the rest of the sediment away from the valve opening. This has been found to be unique only to the straight bill design as supplied by Proco.

18. What is the maximum temperature that the ProFlex™ rubber check valve can handle?

Temperature can range from - 65 Deg to +400 Deg depending on the specified elastomer.

19. What is the life expectancy of the ProFlex™ Rubber check valves?

All of the ProFlex™ valves are manufactured with the highest grade of elastomers, which commonly are known to supply 35-50 years of service life.

