

VB60 (G 1/2, G 3/4) (SS316L)

Features

- Shavo's type 60 Volume Booster amplifies the volume at a 1:1 ratio whenever input isolation or increased flow capacity is required.
- High capacity Volume Booster, with a fixed minimum deadband, are designed to substantially improve the stroking speed of large actuators.
- An integral adjustable bypass valve provide good operational system stability over wide range of actuator sizes.
- Soft Valve seat design minimizes air consumption.
- CE, ATEX, EAC [(CUTR-10) equivalent to GOST R &K] approved.
- SIL3 capable as per IEC 61508.
- All External parts are NACE MR 0175* approved.

*National Association of Corrosion Engineers MR-0175 defines requirements for sulphide stress cracking resistant materials used in oilwells and corrosive environments).



ATEX version

PARAMETERS	SPECIFICATIONS
Fluid	Compressed Air
Pipe size	1/2" , 3/4"
Pipe Thread (Supply/output connection)	NPT - Standard BSPT, BSP - Optional
Signal Connection	1/4" NPT - Standard
Signal / Output Ratio	1 : 1
Supply Pressure	150 psig (10 bar) maximum (not to exceed actuator rating)
Signal / Output Pressure	100 psig (7.0 bar) maximum
Flow Capacity Standard Nominal Flow Rate at 150 psi (10 bar) inlet pressure 87 psi (6 bar) set pressure and a drop of 14.5 psi(1 bar) from set	1/2" Output – 270 scfm, Cv – 4.5 3/4" Output – 300 scfm, Cv – 5.1
Flow capacity (CV)	1/2" Exhaust – 3.8 3/4" Exhaust – 3.8
Signal to output ratio	1:1 ±5% of 100 psi output span
Maximum Operating Temperature	+80°C
Linearity	±1% (FS)
Material of Construction Body, Spacer, Top cover Internals wetted parts	SS316L SS316L, SS304, etc.
Elastomers	Low Temperature Nitrile : -60°C to + 80°C
Weight	2.5 kgs.

Note :Screw, mounting bracket will not be NACE MR 0175 approved.
Exhaust port - M8 tapped.



Non ATEX version

VB60 (G 1/2, G 3/4) (SS316L)

Option Selector

Sample Model Number → **S V B 6 0 - S S 4 A - N B - X X X - X X X**

Position → **0 1 2 3 4 - 5 6 7 8 - 9 10 - 11 12 13 - 14 15 16**

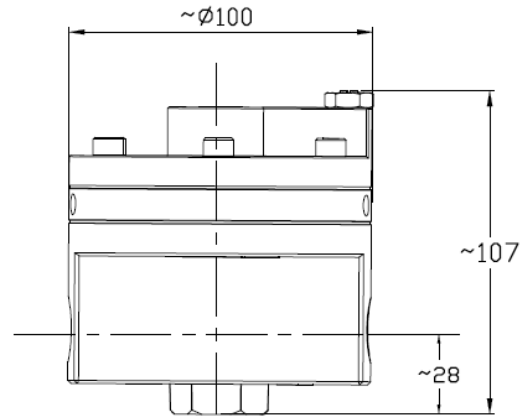
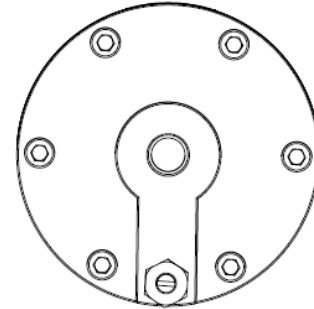
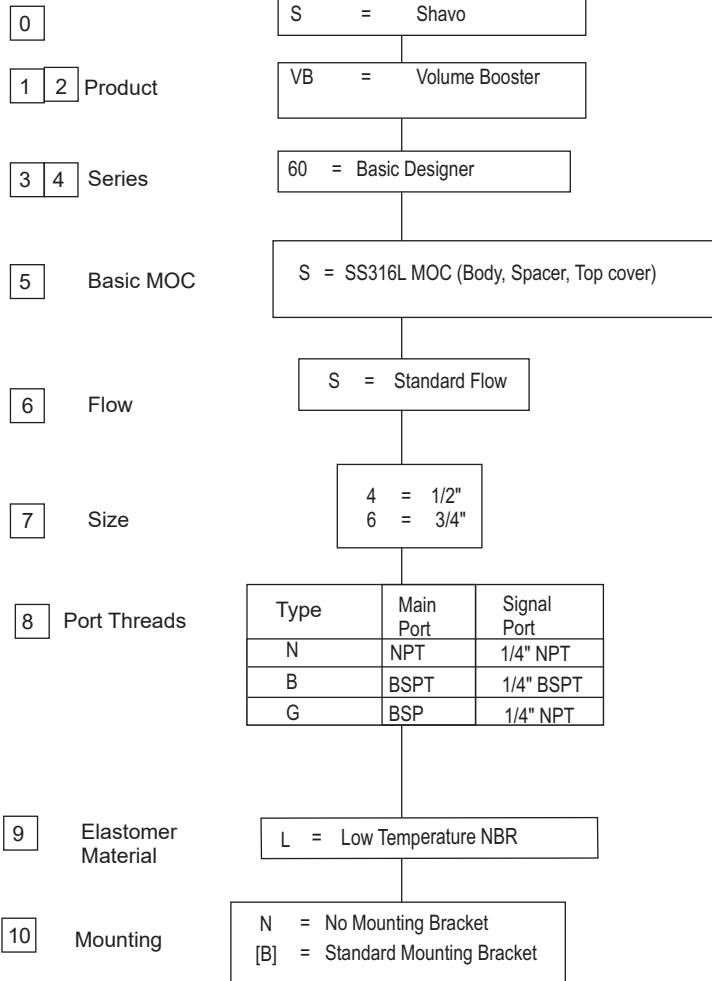

11 12 13 Test / Approval

A	0	0	ATEX
A	0	1	UKEX
A	0	2	UKCA
A	0	3	ATEX, UKEX, EAC Ex, UKCA
A	0	4	ATEX, UKEX, EAC Ex
A	0	5	ATEX, UKEX, UKCA
A	0	6	ATEX, UKEX, EAC Ex
B	0	0	ATEX, CE
B	0	1	ATEX, CE, UKEX, EAC Ex, UKCA
B	0	2	ATEX, CE, UKEX, EAC Ex
B	0	3	ATEX, CE, UKEX, UKCA
B	0	4	ATEX, CE, UKCA, EAC Ex
B	0	5	ATEX, CE, EAC Ex
C	0	0	CE
C	0	1	CE, UKEX, EAC Ex, UKCA
C	0	2	CE, UKEX, EAC Ex
C	0	3	CE, UKEX, UKCA
C	0	4	CE, EAC Ex, UKCA
C	0	5	CE, EAC Ex

VB60 (G 1/2, G 3/4) (SS316L)

D	0	0	ATEX, EAC
D	0	1	ATEX, EAC, UKEX, EAC Ex, UKCA
D	0	2	ATEX, EAC, UKEX, EAC Ex
D	0	3	ATEX, EAC, UKEX, UKCA
D	0	4	ATEX, EAC, EAC Ex, UKCA
E	0	0	EAC
E	0	1	EAC, UKEX, EAC Ex, UKCA
E	0	2	EAC, UKEX, EAC Ex
E	0	3	EAC, UKEX, UKCA
E	0	4	EAC, EAC Ex, UKCA
F	0	0	ATEX, SIL3
F	0	1	ATEX, SIL3, UKEX, EAC Ex, UKCA
F	0	2	ATEX, SIL3, UKEX, EAC Ex
F	0	3	ATEX, SIL3, UKEX, UKCA
F	0	4	ATEX, SIL3, EAC Ex, UKCA
F	0	5	ATEX, SIL3, EAC Ex
G	0	0	CE, EAC
G	0	1	CE, EAC, UKEX, EAC Ex, UKCA
G	0	2	CE, EAC, UKEX, EAC Ex
G	0	3	CE, EAC, UKEX, UKCA
G	0	4	CE, EAC, EAC Ex, UKCA
H	0	0	CE, SIL3
H	0	1	CE, SIL3, UKEX, EAC Ex, UKCA
H	0	2	CE, SIL3, UKEX, EAC Ex
H	0	3	CE, SIL3, UKEX, UKCA
H	0	4	CE, SIL3, EAC Ex, UKCA
H	0	5	CE, SIL3, EAC Ex
J	0	0	EAC, SIL3
J	0	1	EAC, SIL3, UKEX, EAC Ex, UKCA
J	0	2	EAC, SIL3, UKEX, EAC Ex
J	0	3	EAC, SIL3, UKEX, UKCA
J	0	4	EAC, SIL3, EAC Ex, UKCA
K	0	0	CE, EAC, SIL3
K	0	1	CE, EAC, SIL3, UKEX, EAC Ex, UKCA
K	0	2	CE, EAC, SIL3, UKEX, UKCA
K	0	3	CE, EAC, SIL3, UKEX, EAC Ex
K	0	4	CE, EAC, SIL3, EAC Ex, UKCA
L	0	0	ATEX, EAC, SIL3
L	0	1	ATEX, EAC, SIL3, UKEX, EAC Ex, UKCA
L	0	2	ATEX, EAC, SIL3, UKEX, EAC Ex
L	0	3	ATEX, EAC, SIL3, UKEX, UKCA
L	0	4	ATEX, EAC, SIL3, EAC Ex, UKCA
M	0	0	ATEX, CE, SIL3
M	0	1	ATEX, CE, SIL3, UKEX, EAC Ex, UKCA
M	0	2	ATEX, CE, SIL3, UKEX, EAC Ex
M	0	3	ATEX, CE, SIL3, UKEX, UKCA
M	0	4	ATEX, CE, SIL3, EAC Ex, UKCA
N	0	0	ATEX, CE, EAC
N	0	1	ATEX, CE, EAC, UKEX, EAC Ex, UKCA
N	0	2	ATEX, CE, EAC, UKEX, EAC Ex
N	0	3	ATEX, CE, EAC, UKEX, UKCA

VB60 (G 1/2, G 3/4) (SS316L)

N	0	4	ATEX, CE, EAC, EAC Ex, UKCA
[O]	[0]	[0]	Other customer special requirement if Any
P	0	0	ATEX, CE, EAC, SIL3
P	0	1	ATEX, CE, EAC, SIL3, UKEX, EAC Ex, UKCA
P	0	2	ATEX, CE, EAC, SIL3, UKEX, EAC Ex
P	0	3	ATEX, CE, EAC, SIL3, UKEX, UKCA
P	0	4	ATEX, CE, EAC, SIL3, EAC Ex, UKCA
Q	0	0	ATEX, EAC Ex
R	0	0	EAC Ex
R	0	1	EAC Ex, UKEX, UKCA
R	0	2	EAC Ex, UKCA
S	0	0	SIL3
S	0	1	SIL3, UKEX, EAC Ex, UKCA
S	0	2	SIL3, UKEX, EAC Ex
S	0	3	SIL3, UKEX, UKCA
S	0	4	SIL3, EAC Ex, UKCA
V	0	0	ATEX, CE, SIL3, EAC Ex
V	0	1	ATEX, CE, SIL3, EAC Ex, UKEX, UKCA
V	0	2	ATEX, CE, SIL3, EAC Ex, UKEX
V	0	3	ATEX, CE, SIL3, EAC Ex, UKCA
X	X	X	STANDARD UNITS WITHOUT ANY CERTIFICATE / APPROVAL
Y	0	0	ATEX, SIL3, EACEx
y	0	1	ATEX, SIL3, EACEx, UKEX, UKCA
Y	0	2	ATEX, SIL3, EAC Ex, UKEX
Y	0	3	ATEX, SIL3, EACEx, UKCA
Z	0	1	CE, SIL3, EAC Ex, UKEX, UKCA
Z	0	2	CE, SIL3, EAC Ex, UKEX
Z	0	3	CE, SIL3, EAC Ex, UKCA

X	X	X	Standard Unit Without any Compliance
A	0	1	RoHS 3 Compliance
A	0	2	REACH Compliance
A	0	3	Copper Free (Only Applicable Aluminium Version)
A	0	4	RoHS3, REACH Compliance
A	0	5	RoHS3, REACH, Copper Free (Only Applicable for Aluminium Version)
A	0	6	RoHS3, Copper Free (Only Applicable for Aluminium Version)
A	0	7	REACH, Copper Free (Only Applicable for Aluminium Version)

14 15 16 Compliance

Options shown in [] brackets are special, please contact sales HQ / manufacturing.