

8414 N

## DC axial compact fan



### Nominal data

| Type                     | 8414 N            |          |
|--------------------------|-------------------|----------|
| Nominal voltage          | VDC               | 24       |
| Nominal voltage range    | VDC               | 18 .. 28 |
| Speed (rpm)              | min <sup>-1</sup> | 3100     |
| Power consumption        | W                 | 1.8      |
| Min. ambient temperature | °C                | -20      |
| Max. ambient temperature | °C                | 70       |
| Air flow                 | m <sup>3</sup> /h | 69       |
| Sound power level        | B                 | 4.7      |
| Sound pressure level     | dB(A)             | 32       |

ml = Max. load · me = Max. efficiency · fa = Free air · cs = Customer specification · ce = Customer equipment  
Subject to change

**Technical description**

|  |   |
|--|---|
| <b>Housing material</b>                        | Glass-fiber reinforced PBT plastic  |
| <b>Impeller material</b>                       | Glass-fiber reinforced PA plastic   |
| <b>Weight</b>                                  | 0.095 kg  |
| <b>Dimensions</b>                              | 80 x 80 x 25 mm   |
| <b>Airflow direction</b>                       | Exhaust over struts   |
| <b>Direction of rotation</b>                   | Counterclockwise, viewed toward rotor   |
| <b>Storage</b>                                 | Ball bearing  |
| <b>Service life L10 at 40 °C</b>               | 70000 h   |
| <b>Service life L10 at maximum temperature</b> | 35000 h   |
| <b>Cable</b>                                   | Leads AWG 24, TR 64, stripped and tin-plated.   |
| <b>Motor protection</b>                        | Protection against reverse polarity and blocked rotor.  |
| <b>Locked-rotor protection</b>                 | Locked-rotor and overload protection  |
| <b>Approval</b>                                | VDE, CSA, UL, CE  |
| <b>Option</b>                                  | Possible custom designs:<br>Speed signal<br>Go / No-go alarm<br>Alarm with speed limit<br>External temperature sensor<br>Internal temperature sensor<br>PWM control input<br>Analog control input<br>Moisture protection<br>Degree of protection: IP54 / IP68 |

8414 N

# DC axial compact fan

## Product drawing

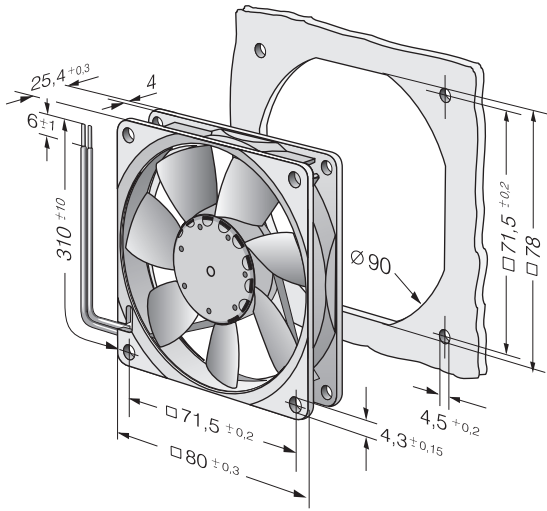

Curves: Air performance

