

EMCORE's 1782 laser module is characterized for use as a CW optical source in CATV and DWDM networks. The 1782 is dc-coupled with a built-in TEC, thermistor, and monitor photodiode. The device is mounted in a 14-pin, OC-48 pinout compatible butterfly package with the optical isolator mounted on the TEC. The 1782 incorporates a high efficiency coupling scheme to deliver 40 mW, 50 mW, 63 mW, 80 mW and 100 mW of CW optical power.

## Applications

- DWDM
- CATV
- Free Space Optics

## Features

- 40, 50, 63, 80 & 100 mW Optical Output Power
- OC-48 Pinout Compatible
- Telcordia Technologies® GR-468 Compliant
- PM Fiber
- -20°C to +65°C Operating Temperature Range
- Monitor Photodiode
- RoHS

## Performance Highlights

Parameter	Min	Typ	Max	Units	
Operating Case Temperature	-20	25	+65	°C	
Wavelength	1550			nm	
Optical Output Power	40 50 63 80 100	- - - - -	- - - - -	mW	
Threshold Current	-	-	40	mA	
Operating Current	-	-	650	mA	
RIN	-	-	-163	dB/Hz	
RIN Through 65 km Fiber					
	Standard	-	-	-155	dB/Hz
	Enhanced	-	-	-157	dB/Hz
SMSR	30	-	-	dB	
Polarization Extinction Ratio (PMF pigtail)	17	-	-	dB	
Optical Return Loss	40	-	-	dB	

## Absolute Maximum Ratings

Stresses in excess of the absolute maximum ratings can cause permanent damage to the device. These are absolute stress ratings only. Functional operation of the device is not implied at these or any other conditions in excess of those given in the operational sections of the data sheet. Exposure to absolute maximum ratings for extended periods can adversely affect device reliability.

Parameter	Symbol	Condition	Min	Max	Units
Operating Case Temperature	T <sub>OP</sub>	continuous	-20	+65	°C
Storage Temperature	T <sub>STG</sub>	continuous	-40	+85	°C
Laser Forward dc Current	-	continuous	-	750	mA
Photodiode Reverse Voltage	V <sub>R,MPD</sub>	continuous	-	10	V
Laser Reverse Voltage	-	continuous	-	2	V
TEC current	I <sub>TEC</sub>	continuous	-	1.7	A
ESD	-	HBM: R = 1500 Ω, C = 100 pF	-500	500	V

## Electrical/Optical Characteristics

Parameter	Symbol	Condition	Min	Typ	Max	Unit
Operating Case Temperature	T <sub>OP</sub>	-	-20	25	65	°C
Optical Output Power	P <sub>O</sub>	40 mW version, T = T <sub>set</sub> , I <sub>F</sub> = I <sub>OP</sub> 50 mW version, T = T <sub>set</sub> , I <sub>F</sub> = I <sub>OP</sub> 63 mW version, T = T <sub>set</sub> , I <sub>F</sub> = I <sub>OP</sub> 80 mW version, T = T <sub>set</sub> , I <sub>F</sub> = I <sub>OP</sub> 100 mW version, T = T <sub>set</sub> , I <sub>F</sub> = I <sub>OP</sub>	40 50 63 80 100	- - - -	- - -	mW
Threshold Current	I <sub>TH</sub>	BOL	-		40	mA
Operating Current	I <sub>OP</sub>	BOL, T=Top 100 mW Option 80 mW Option 63 mW Option 50 mW Option 40 mW Option	- - - - -	- - - - -	650 600 500 400 350	mA
Operating Laser Temperature	-		18	-	35	°C
Laser Bias Forward Voltage	V <sub>OP</sub>	BOL, I <sub>F</sub> = I <sub>OP</sub>	-	-	2.7	V
Wavelength	λ <sub>OP</sub>	T = T <sub>set</sub> , I <sub>F</sub> = I <sub>OP</sub>	1550			nm
Equivalent Lorentzian Linewidth <sup>(1)</sup>	Δν	T = T <sub>set</sub> , I <sub>F</sub> = I <sub>OP</sub> , FWHM	-	-	1.0	MHz
Optical Return Loss	ORL	-	40	-	-	dB
Sidemode Suppression Ratio	SMSR	-	30	-	-	dB
Polarization Extinction Ratio	PER	I <sub>F</sub> = I <sub>OP</sub>	17	-	-	dB
Wavelength Drift Over T <sub>C</sub> Range	Δν <sub>TOP</sub>	T = T <sub>OP</sub>	-	-	40	pm
Relative Intensity Noise	RIN	-	-	-	-155	dB/Hz
Monitor PD Current	I <sub>MPD</sub>	I <sub>F</sub> = I <sub>OP</sub> , V <sub>MPD</sub> = -5 V	100	-	2500	μA
Monitor PD Dark Current	I <sub>D</sub>	I <sub>OP</sub> = 0 mA, V <sub>MPD</sub> = -5 V	-	-	0.2	μA
Thermistor Resistance	R <sub>TH</sub>	T <sub>OP</sub> = 25 °C	9.5	10.0	10.5	KΩ
Thermistor Temp. Coefficients	TC <sub>TH</sub>	T <sub>OP</sub> = 25 °C	-	-4.4	-	%/°C
TEC Current	I <sub>TEC</sub>	-20°C < T <sub>C</sub> < +65°C	-1.0	-	+1.5	A
TEC Voltage	V <sub>TEC</sub>	-20°C < T <sub>C</sub> < +65°C	-2.0	-	+3.0	V

1. The RIN-through-fiber delta increase in RIN at 860 MHz measurement frequency can be related to the linewidth of a source having an ideal Lorentzian lineshape using the following theoretical expression:  $\Delta\nu = \Delta RIN(f) \{4 \pi (D\lambda^2 L/c)^2 f^2\}^{-1}$   
 D = fiber dispersion (assumed 17 ps/(nm\*km)), L = fiber length (65 km), c = speed of light in free space

## Outline Drawing

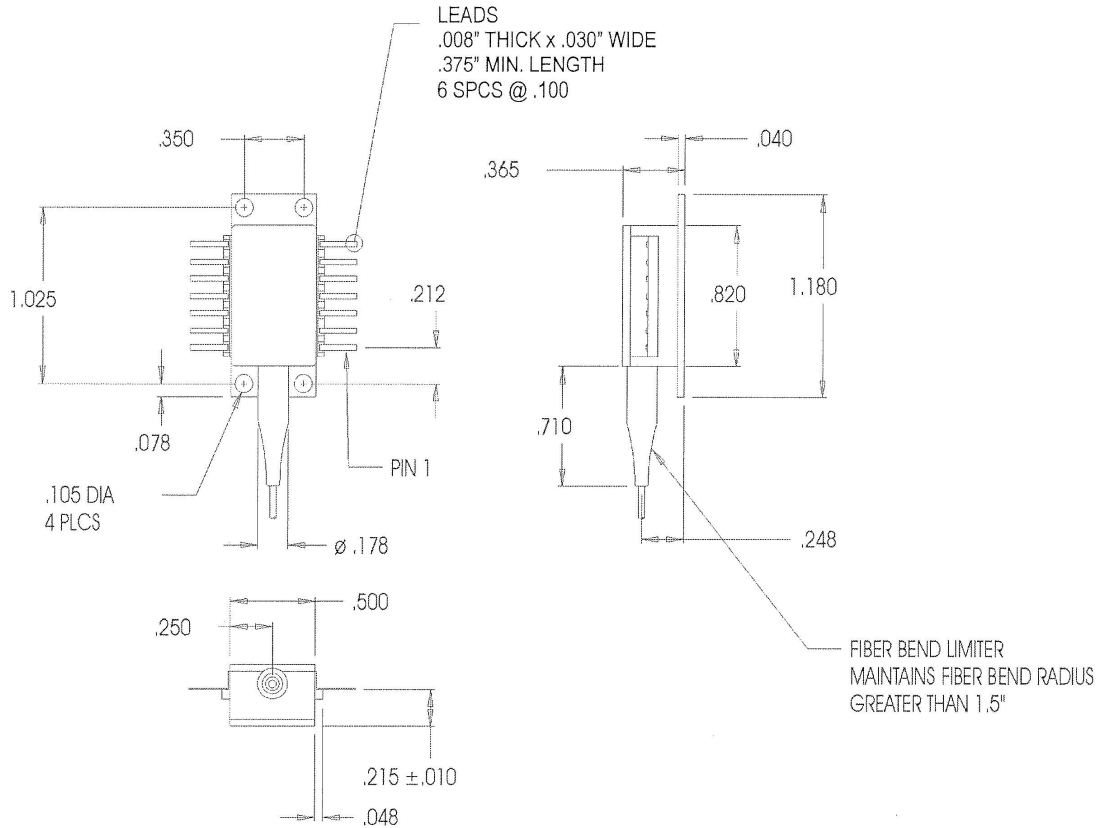

## Pin Assignments

Pin	Description
1	Thermistor
2	Thermistor
3	Dc Laser Bias (-)
4	MPD Anode (-)
5	MPD Cathode (+)
6	Thermal Electric Cooler (+)
7	Thermal Electric Cooler (-)
8	Case Ground
9	Case Ground
10	NC
11	Laser Common (+), Case Ground
12	Laser Modulation (-)
13	Laser Common (+)
14	NC

## ITU Grid Channel Numbering

Please contact EMCORE Sales for ITU Wavelength Channel availability.

## Package Schematic

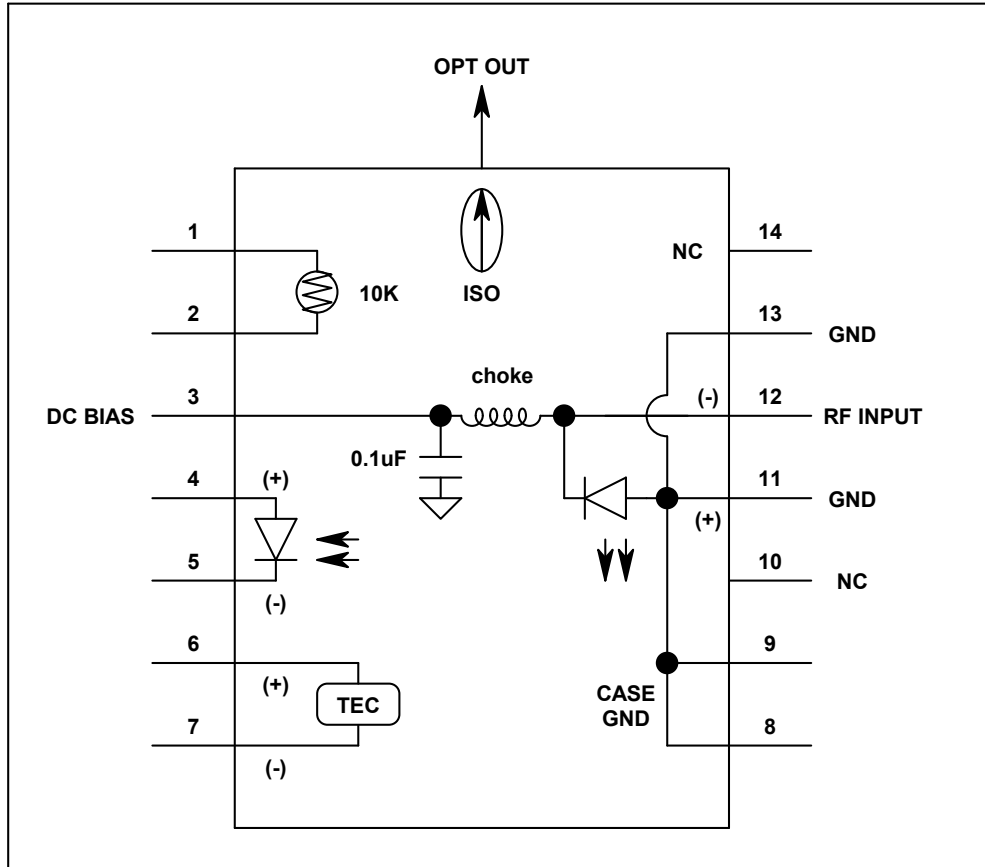

## Laser Safety

This product complies with 21 CFR 1040.10 and 1040.11 except for deviations pursuant to Laser Notice No. 50, dated June 24, 2007.

All Versions of this laser are Class 1M laser product, tested according to IEC 60825-1:2007/EN 60825-1:2007 Single-mode fiber pigtail with FC/APC connectors (standard).

Wavelength = 1.5  $\mu$ m.

Maximum power = 100 mW.

Because of size constraints, laser safety labeling (including an FDA class 1M label) is not affixed to the module, but attached to the outside of the shipping carton.

Product is not shipped with power supply.

**Caution: Use of controls, adjustments and procedures other than those specified herein may result in hazardous laser radiation exposure.**

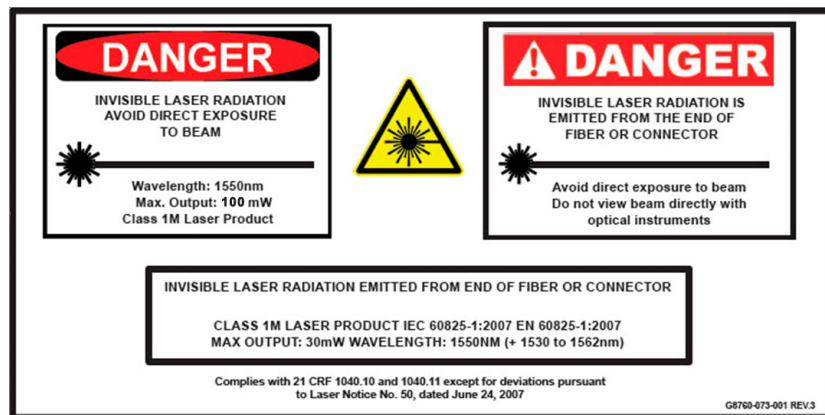

## Ordering Code Definitions

1782x – NM – xxx – yy – FC - PM

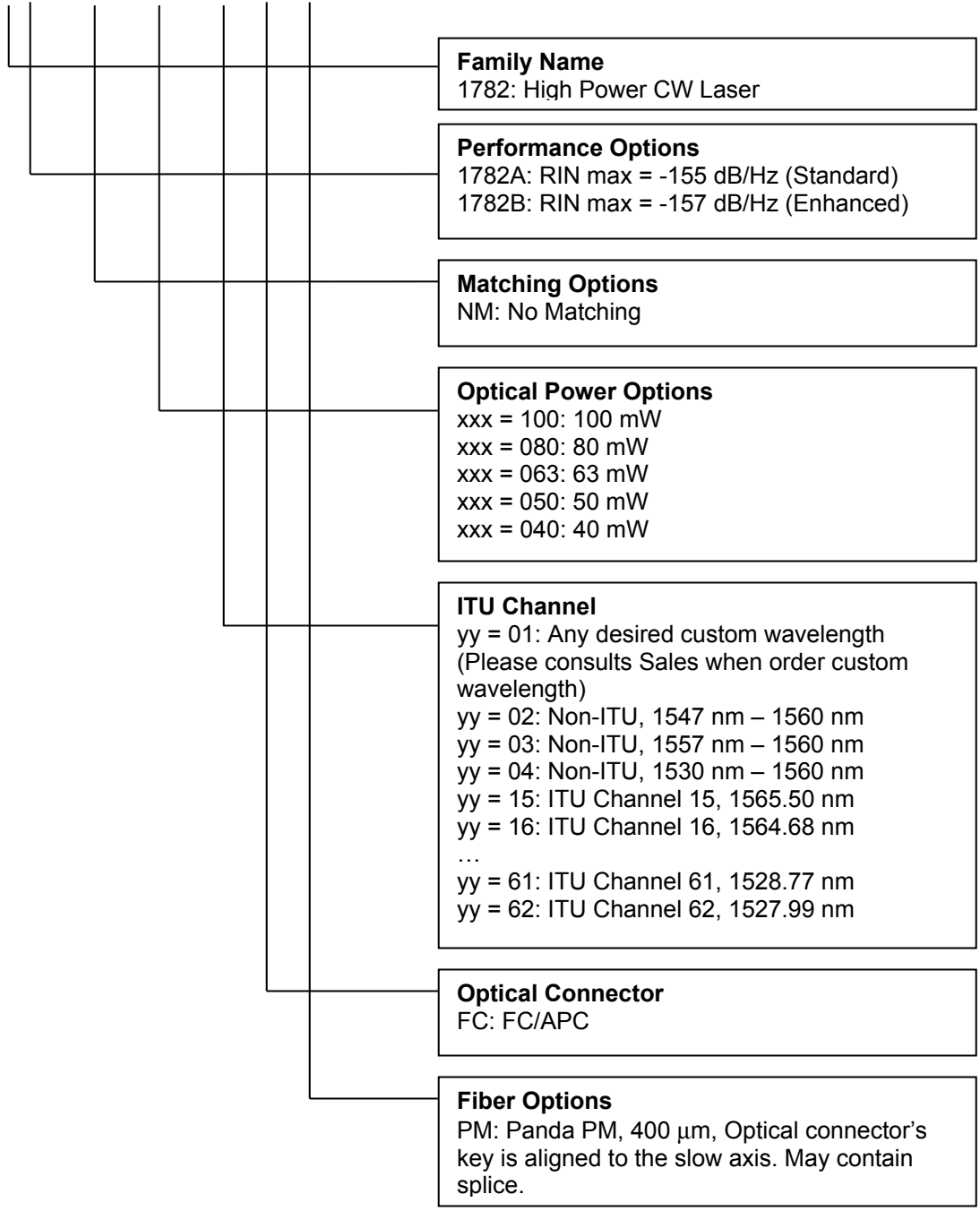

### Example

**1782B-NM-100-18-FC-PM:** CW Laser, Enhanced RIN, Non Matching, 100mW, Channel 18, FC/APC, PM fiber