

Proportional electrohydraulic controls for PVPC pumps

pressure-flow alternate P/Q controls, analog or digital

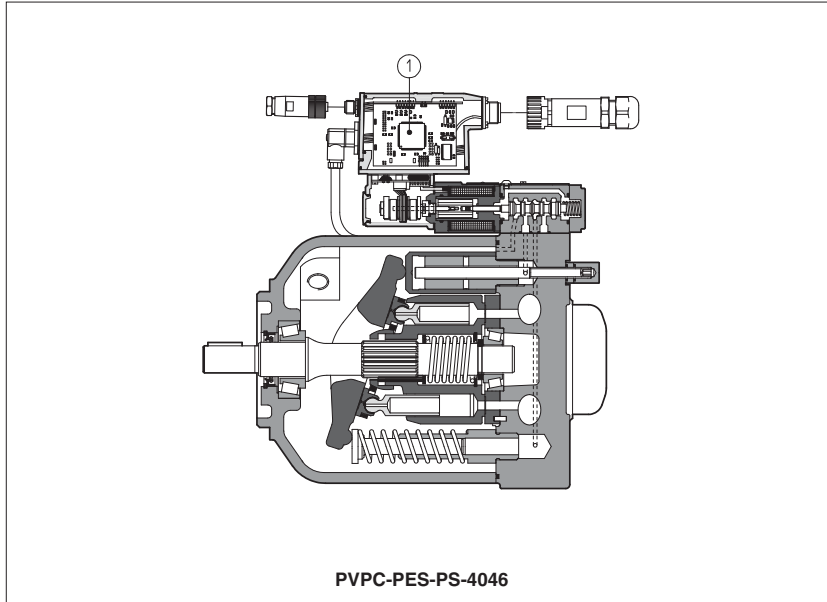

The variable displacement axial piston pumps type PVPC, can be supplied with advanced electrohydraulic proportional controls:

- open loop pressure control;
 - load sensing flow control;
 - Open and closed loop P/Q controls;
- They allow to perform high dynamics and fine regulations, directly commanded from PLC or from the machine controller. They are available with separated driver or with integral electronics ①.

New PES digital controllers, integrated to the pump, realize alternate closed loop controls of pressure, flow and max power limitation. The P/Q controls are also available with optional sequence module (LZQZR or PERS versions) that allow to operate the pump with minimum pressure in the circuit close to zero. Following communication interfaces are available for the digital PE(R)S execution, see section ②:

- **-PS:** Serial
- **-BC:** CANopen
- **-BP:** PROFIBUS DP

For technical characteristics and features of the PVPC pumps, see table A160.

1 MODEL CODE

PVPC	X2E	- PERS	- BC	- 4	046	/31044 /	*	/1	D / 18	10	/*
Variable displacement axial piston pump											Synthetic fluids: WG = water-glycol PE = phosphate ester See notes, section ②
Additional suffix for double pumps X2E = with a fixed displacement pump type PFE (see tab. A005)											Series number
Type of control (see section ⑦ and ⑧): CZ = proportional pressure compensator LQZ = proportional flow control (load sensing) LZQZ = proportional pressure & flow control (load sensing) LZQZR = as LZQZ plus sequence module PES = closed loop integral digital P/Q controller PERS = as PES plus sequence module											Options, for CZ, LQZ, LZQZ see sections ③: 18 = with 18 VDC coil instead of standard 12 VDC coil Electronics options for PES and PE(R)S see sections ④ and ⑤: I = current reference input and monitor output signals (4 ÷ 20 mA) C = current feedback input signal (4÷20 mA) for remote pressure transducer X = with integral pressure transducer (only for PERS) S = with two on-off inputs for multiple pressure PID selection (PS execution) or double power supply (BC and BP execution)
Communication interface, only for PES and PERS versions PS = Serial BP = PROFIBUS DP BC = CANopen											Direction of rotation (viewed at the shaft end) D = clockwise S = counterclockwise
Size: 3 = for displacement 029 4 = for displacement 046 5 = for displacement 073 and 090											Shaft (SAE Standard): 1 = keyed (7/8" for 029 - 1" for 046 - 1 1/4" for 073 and 090) 5 = splined (13 teeth for 029 - 15 for 046 - 14 for 073 and 090)
Max displacement: 029 = 29 cm ³ /rev 046 = 46 cm ³ /rev 073 = 73 cm ³ /rev 090 = 88 cm ³ /rev											
Type of PFE (for double pumps), see tab. A005											
Pressure setting (only for PERS): 200 = 200 bar 250 = 250 bar 280 = 280 bar											

1) pumps with ISO 3019/2 mounting flange and shaft (option /M) are available on request

2 OPERATING CHARACTERISTICS

Pump model		PVPC-3029	PVPC-4046	PVPC-5073	PVPC-5090
Displacement	[cm ³ /rev]	29	46	73	88
Theoretical max flow at 1450 rpm	[l/min]	42	66,7	105,8	127,6
Max working pressure / Peak pressure	[bar]	280/350	280/350	280/350	250/315
Min/Max inlet pressure	[bar abs.]	0,8 / 25	0,8 / 25	0,8 / 25	0,8 / 25
Max pressure on drain port	[bar abs.]	1,5	1,5	1,5	1,5
Power consumption at 1450 rpm and at maximum pressure and displacement	[kW]	19,9	31,6	50,1	54,1
Max torque on the first shaft	[Nm]	Type 1 200	Type 1 230	Type 1 490	Type 1 490
		Type 5 190	Type 5 330	Type 5 620	Type 5 620
Max permissible load on drive shaft	[N]	$\frac{F_{ax}}{F_{rad}}$	$\frac{F_{ax}}{F_{rad}}$	$\frac{F_{ax}}{F_{rad}}$	$\frac{F_{ax}}{F_{rad}}$
		1000 1500	1500 1500	2000 3000	2000 3000
Speed rating	[rpm]	600 ÷ 3000	600 ÷ 2600	600 ÷ 2200	600 ÷ 1850

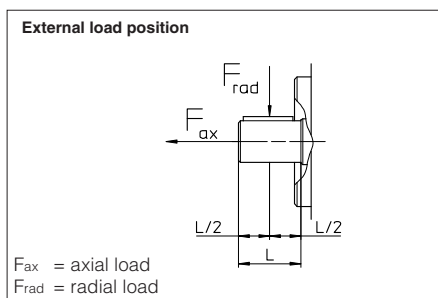

Notes: For speeds over 1800 rpm the inlet port must be under oil level with adequate pipes.
Maximum pressure for all models with option /WG is 160 bar, with option /PE is 190 bar.
Max speed with options /WG and /PE is 2000/1900/1600/1500 rpm respectively for the four sizes.

3 MAIN CHARACTERISTICS OF VARIABLE DISPLACEMENT AXIAL PISTON PUMP TYPE PVPC

Installation position	Any position. The drain port must be on the top of the pump. Drain line must be separated and unrestricted to the reservoir and extended below the oil level as far from the inlet as possible. Suggested maximum line length is 3 m.		
Ambient temperature	from -20°C to +70°C for versions with separated electronics / from -20°C to +60°C for versions PES/PERS		
Fluid	Hydraulic oil as per DIN 51524...535; for other fluids see section 11		
Recommended viscosity	15÷100 mm ² /sec at 40°C (ISO VG 15÷100). Maximum start-up viscosity: 1000 mm ² /sec		
Fluid contamination class	ISO 16/13 (filters at 10 µm value with β ₁₀ ≥ 75 recommended)		
Fluid temperature	-20°C +70°C	-20°C +50°C (seals /WG)	-20°C +80°C (seals /PE)
Power supply for pressure transducer (PES, PERS)	24 V _{DC}		

3.1 Coils characteristics - only for CZ, LQZ, LZQZ(R) executions

Coil resistance R at 20°C	Pump size 3	3 ÷ 3,3 Ω for standard 12 V _{DC} coil; 13 ÷ 13,4 Ω for 18 V _{DC} coil (only for version CZ, LQZ, LZQZ*)
	Pump sizes 4, 5	3,8 ÷ 4,1 Ω for standard 12 V _{DC} coil; 12 ÷ 12,5 Ω for 18 V _{DC} coil (only for version CZ, LQZ, LZQZ*)
Max solenoid current	2,6 A for standard 12 V _{DC} coil; 1,5 A for 18 V _{DC} coil (available only for version CZ, LQZ, LZQZ*)	
Max power	35 Watt	
Protection degree (CEI EN-60529)	IP65 for -CZ, LQZ and LZQZ; IP65÷67 for versions with integral electronics (see section 17)	
Duty factor	Continuous rating (ED = 100%)	

4 ELECTRONIC DRIVERS

Pump model	CZ, LQZ, LZQZ(R)						PES, PERS
Drivers model	E-MI-AC-01F	E-MI-AS-IR	E-BM-AC	E-BM-AS-PS	E-ME-AC	E-RP-AC	E-RI-PES
Data sheet	G010	G020	G025	G030	G035	G100	G215

Note: for power supply and communication connector see section 11

5 GENERAL NOTES

Atos proportional pumps are CE marked according to the applicable directives (e.g. Immunity/Emission EMC Directive and Low Voltage Directive). Installation, wirings and start-up procedures must be performed according to the general prescriptions shown in table F003 and in the user manuals included in the E-SW programming software. The electrical signals of the pump (e.g. monitor signals) must not be directly used to activate safety functions, like to switch-ON/OFF the machine's safety components, as prescribed by the European standards (Safety requirements of fluid technology systems and components-hydraulics, EN-892)

6 CONNECTIONS FOR CZ, LQZ, AND LZQZ(R)

SOLENOID POWER SUPPLY CONNECTOR	
PIN	Signal description
1	SUPPLY
2	SUPPLY
3	GND

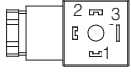

7 PRESSURE TRANSDUCER SELECTION (excluded option /X)

The pressure transducer type E-ATR-7 must be ordered separately (see table G465) For option X the pressure transducer is integral to the pump.

Pump code:	Pressure transducer code:
PVPC-PER(S)-*/200	E-ATR-7/250
PVPC-PER(S)-*/250	E-ATR-7/400
PVPC-PER(S)-*/280	E-ATR-7/400
PVPC-PER(S)-*/200*/C	E-ATR-7/250/I
PVPC-PER(S)-*/250*/C	E-ATR-7/400/I
PVPC-PER(S)-*/280*/C	E-ATR-7/400/I

8 ELECTRONICS OPTIONS FOR PES AND PERS

Standard execution provides on the 12 pin main connector:

Power supply	-The power supply must be appropriately stabilized or rectified and filtered: apply at least a 10000 µF/40 V capacitance to single phase rectifiers or a 4700 µF/40 V capacitance to three phase rectifiers. A safety fuse is required in series to each driver power supply: 2,5 A fuse
Reference input signals	-The driver controls in closed loop both the pump flow and pressure proportionally to the external reference input signals. The driver is designed to receive two analog reference input signals both referred to the common mode signal zero (AGND). The inputs range and polarity are software selectable within the ±10 V _{DC} maximum range; default settings are 0 ÷ +10 V _{DC} . Driver with fieldbus interface (-BC or -BP) can be software set to receive reference values directly by the machine control unit (fieldbus master); in this case the analog reference input signals can be used for start-up and maintenance operations.
Monitor output signals	-The driver generates an analog output signals proportional to the actual pump swashplate position and to the actual pressure on the pump outlet line; the monitor output signals can be software set to show other signals available in the driver (e.g. analog reference, fieldbus reference, pilot spool position). The output polarity is software selectable within ±10 V _{DC} maximum range; default settings are 0 ÷ +10 V _{DC} .
Fault Output Signal	-Fault output signal indicates fault conditions of the driver (solenoid short circuits/not connected, reference signal cable broken for 4 ÷ 20mA input, pressure/swashplate/pilot transducer cable broken, etc.). Fault presence corresponds to 0 V _{DC} , normal working corresponds to 24 V _{DC} (pin 11 referred to pin2). Fault status is not affected by the status of the Enable input signal
Enable Input Signal (only for /S and /SX options)	-To enable the driver, supply a +24V _{DC} on pin 3 referred to pin 2: when the Enable signal is set to zero the pump functioning is disabled but the driver current output stage is still active. This condition does not comply with European Norms EN954-1.

For other functions, see table G215.

Following options are available to standard execution to special application requirements.

8.1 Option /I

It provides 4÷20 mA current reference and monitor signals instead of the standard 0÷+10 V_{DC}.

It is normally used in case of long distance between the machine control unit and the pump or where the reference signal can be affected by electrical noise; the valve functioning is disabled in case of reference signal cable breakage.

8.2 Option /C

The pump electronics is set to receive 4÷20 mA feedback signal from the remote pressure transducer, instead of the standard 0÷10 V.

8.3 Option /X (only for -PERS)

Option providing the presence of the pressure transducer, with output signal 4÷20 mA, integral to the pump and factory wired to the PES electronics through a cable gland.

8.4 Option /S

Multiple pressure PID selection (only for /S and /SX options in -PS execution)

Two on-off input signals are available on the main connector to switch the active pressure PID parameters among one of the four setting stored into the driver.

Supply a 24V or a 0V on pin 9 and/or 10, to select one of the PID settings as indicated in the table beside.

PID SET SELECTION				
PIN	SET 1	SET 2	SET 3	SET 4
9	0	0	24 V _{DC}	24 V _{DC}
10	0	24 V _{DC}	24 V _{DC}	0

Logic power supply (only for /S and /SX options in -BC or /BP execution)

Separate power supply for the solenoid (pin 1,2) and for the digital electronic circuits (pin 9,10).

Cutting solenoid power supply allows to interrupt the valve functioning but keeping energized the digital electronics thus avoiding fault conditions of the machine fieldbus controller (e.g. for emergency, as provided by the European Norms EN954-1 for components with safety class 2).

Note: pin 2 and 10 (zero Volt) are connected together inside the electronics;

8.5 Possible combined options: /CS, /SX, /IC, /IS, /IX, /ICS and /ISX.

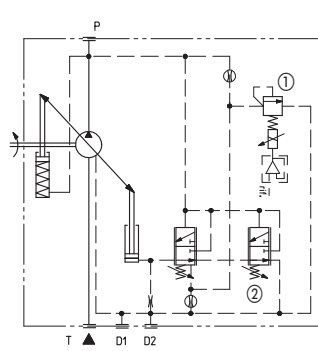

CZ

Proportional pressure compensator

The pumps displacement, and thus the flow, remains constant as far the pressure in the circuit reaches the value set on the proportional pilot valve ①, then the flow is reduced to maintain the circuit pressure to the value set by the electronic reference signal to the proportional valve. In this conditions the pressure in the circuit can be continuously modulated by means of the reference signal.
 Proportional pressure setting range: see below pressure control diagram.
 Compensator setting range ②: 20÷350 bar (315 bar for 090)
 Compensator factory setting ②: 280 bar (250 bar for 090)

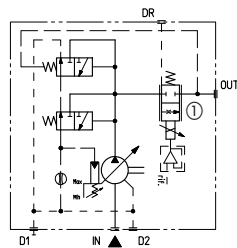
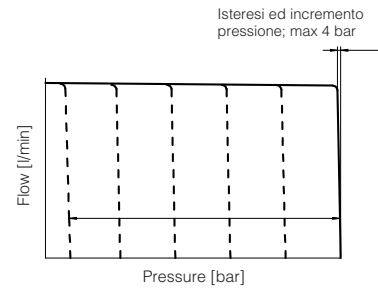

LQZ

Proportional flow (load-sensing)

Open loop control of the flow rate via an reference signal to the electronic driver of the pilot proportional valve. This energy saving control regulates the outlet pressure up to the minimum level required to operate the flow set by the reference signal to the proportional valve ①.

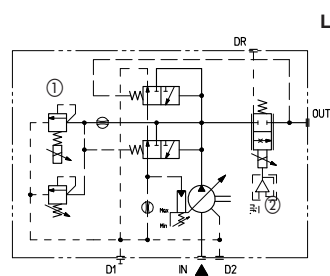
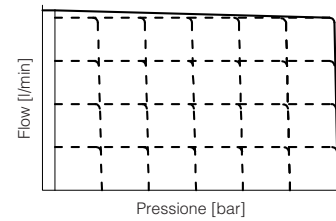

LZQZ

Proportional pressure & flow (load sensing)

Open loop control of pressure ① and flow ② via two reference signals to the electronic drivers of the two pilot proportional valves. This energy saving control regulates the outlet pressure up to the minimum level required to operate the flow set by the reference signal.
 In addition the proportional pressure control reduces the outlet flow, as per CZ control once max pressure is reached.
 Minimum regulated pressure: 15 bar
 For lower minimum regulated pressure, consult our technical office.
 Maximum allowed pressure: 250 bar

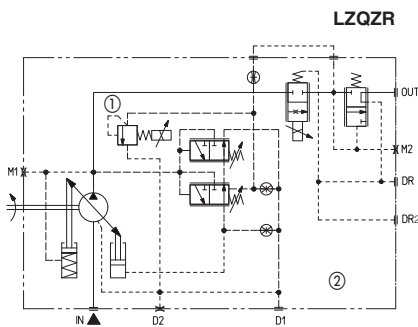
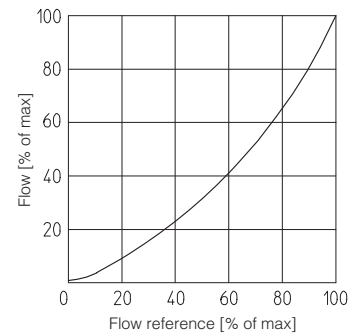

LZQZR

Flow and pressure proportional control with sequence module.

Same construction concept of LZQZ control, in addition it is equipped with RES ② sequence module which ensures the minimum pump piloting pressure in case the system pressure drops below the minimum value (18 bar).

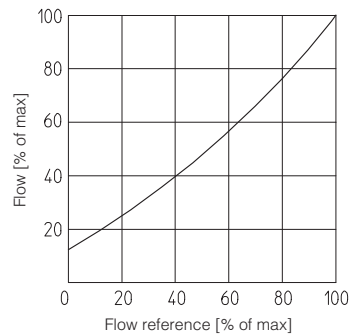

Note: DR2 is available only for size 50.

Diagrams for CZ, LQZ, LZQZ

Regulation diagrams

- 1 = Flow control
- 2 = Pressure control

- (1) for standard 12 Vdc coil
- (2) for 18 Vdc coil

**Pump size
88 73 46 29 cm³/rev**

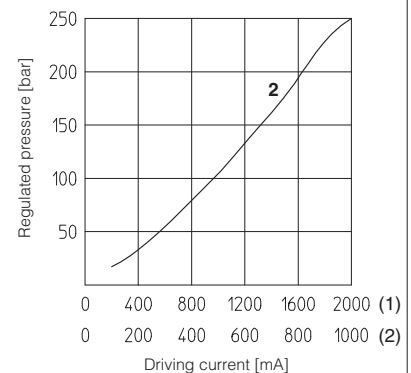
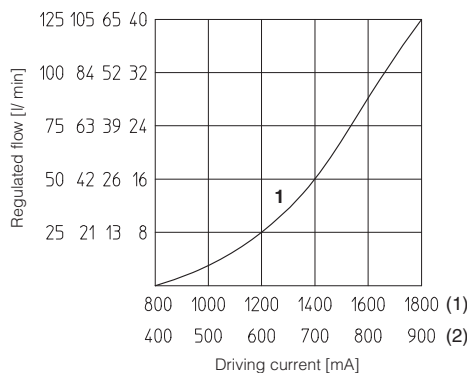

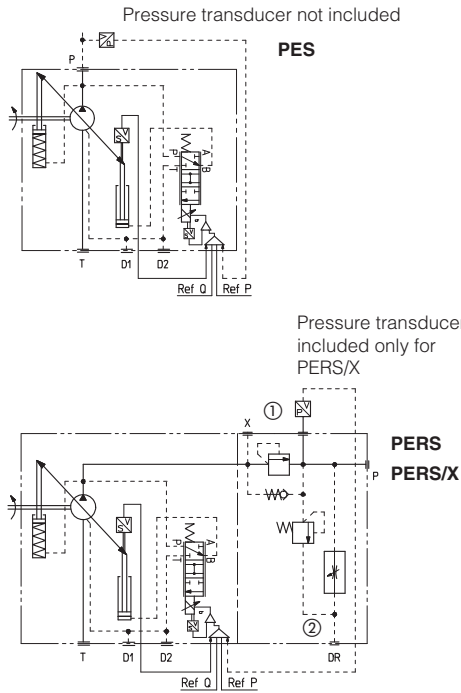

Digital P/Q controller integrates the alternate pressure and flow regulation with the electronic max power limitation.
 A remote pressure transducer must be installed on the system and its feedback has to be interfaced to the pump digital driver.
 Flow control is active when the actual system pressure is lower than the pressure reference input signal: the pump flow is regulated according to the flow reference input. Pressure control is activated when the actual pressure grows up to the pressure reference input signal: the pump flow is then reduced in order to regulate and limit the max system pressure (if the pressure tends to decrease under its command value, the flow control returns active). This option allows to realize accurate dynamic pressure profiles. Following communication interfaces are available:

- PS, Serial communication interface. The pump reference signals are provided with analog commands via the 12 pins connector
- BC, CANopen interface
- BP, PROFIBUS DP interface

The pumps with -BC or -BP interfaces can be integrated into a fieldbus communication network and thus digitally operated by the machine control unit. The digital control ensures high performances as flow and pressure linearity (see diagram 1), better flow knee (see diagram 2), internal leakage compensation (controlled flow independent to the load variations).

- PVPC-PES** basic version, without sequence module and without pressure transducer, which has to be installed on the main line and wired to the 12 poles connector of the integral digital electronics.
- PVPC-PERS** version with sequence module RES ② which grant a minimum piloting pressure (18 bar) when the actual pressure falls below that value. Without pressure transducer.
- PVPC-PERSX** as -PERS version plus integral pressure transducer, with output signal 4÷20 mA, factory wired to the pump digital electronics through a cable gland.

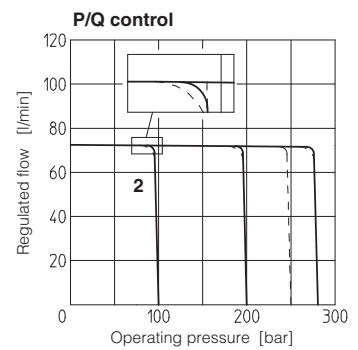
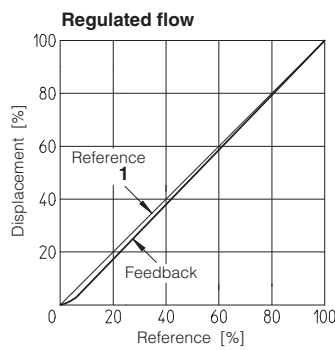
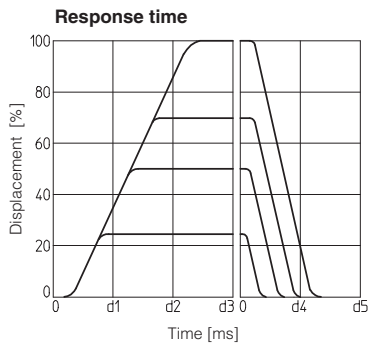

Type pump	d1	d2	d3	d4	d5
	[ms]				
PVPC-PE(R)S-3029	30	60	90	30	60
PVPC-PE(R)S-4046	40	80	120	40	80
PVPC-PE(R)S-5073	50	100	150	50	100
PVPC-PE(R)S-5090	60	120	170	60	120

Response time of displacement variation for a step change of the electronic reference signal.

11 SOFTWARE TOOLS

The functional parameters of the digital valves, as the bias, scale, ramp and linearization of the regulation characteristic, can be easily set and optimized with graphic interface by using the Atos E-SW/S software and the relevant USB adapters, cable and terminators, **see tab. G500**. Valves with fieldbus communication interface (-BC and -BP) can be completely managed by the machine control unit; it is required to implement in the machine control the standard communication as described in the user manuals supplied with the relevant programming software. For detailed description of available fieldbus features, **see tab. G510**

12 DIGITAL INTEGRAL DRIVERS -PE(R)S MAIN FUNCTION AND ELECTRONICS CONNECTIONS

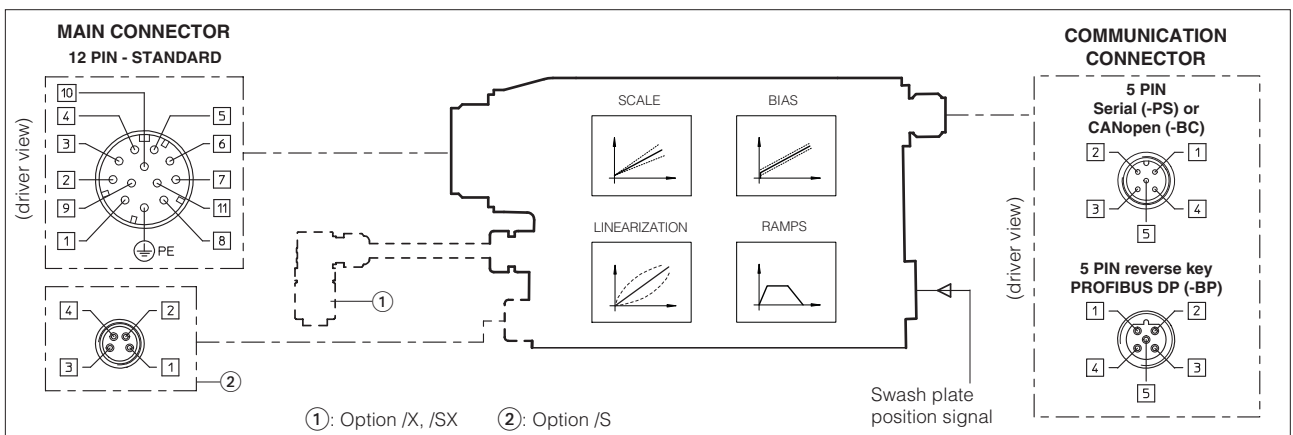

①: Option /X, /SX ②: Option /S

13 ELECTRONIC CONNECTIONS - Standard, Standard with /X and /C options

PIN	SIGNAL	TECHNICAL SPECIFICATIONS	NOTES
1	V+	Power supply 24 Vdc for pilot valve's solenoid power stage	Input - power supply
2	V0	Power supply 0 Vdc for pilot valve's solenoid power stage	Gnd - power supply
3	FAULT	Driver status: Fault (0Vdc) or normal working (24 Vdc)	Output - on/off signal
4	AGND	Ground: signal zero for MONITOR signals (pin 6,8) and INPUT+ signals (pin 5,7)	Gnd - analog signal
5	Q_INPUT+	Flow reference: ± 10 Vdc maximum range (4 \div 20 mA for /I option)	Input - analog signal
6	Q_MONITOR	Flow monitor: ± 10 Vdc maximum range (4 \div 20 mA for /I option)	Output - analog signal
7	P_INPUT+	Pressure reference: ± 10 Vdc maximum range (4 \div 20 mA for /I option)	Input - analog signal
8	P_MONITOR	Pressure monitor: ± 10 Vdc maximum range (4 \div 20 mA for /I option)	Output - analog signal
9	D_IN	Power limitation enable, multiple pressure PID selection or driver enable (software selectable)	Input - on/off signal
PE	EARTH	Internally connected to driver housing	
Standard with /X option			
10	NC	Do not connect for pumps with integral pressure transducer	
11	NC		
Standard and /C option			
10	TR+	Remote pressure transducer feedback: 0 \div 10 Vdc maximum range (4 \div 20 mA) Input differential TR+ and TR-	Input - analog signal
11	TR-		

Note: A minimum time of 270 to 590 ms have be considered between the driver energizing with the 24 Vdc power supply and when the pump is ready to operate; during this time the current to the valve coils is switched to zero.
These connections are the same of Rexroth A10VSO axial piston pumps, model SYDFEE and SYDFEC.

14 ELECTRONIC CONNECTIONS - /S, /SX and /CS options

PIN	SIGNAL	TECHNICAL SPECIFICATIONS	NOTES
1	V+	Power supply 24 Vdc for pilot valve's solenoid power stage	Input - power supply
2	V0	Power supply 0 Vdc for pilot valve's solenoid power stage	Gnd - power supply
3	ENABLE	Enable (24 Vdc) or disable (0 Vdc) the driver	Input - on/off signal
4	Q_INPUT+	Flow reference: ± 10 Vdc maximum range (4 \div 20 mA for /I option)	Input - analog signal
5	AGND	Ground: signal zero for MONITOR signals (pin 6,8) and INPUT+ signals (pin 5,7)	Gnd - analog signal
6	Q_MONITOR	Flow monitor: ± 10 Vdc maximum range (4 \div 20 mA for /I option)	Output - analog signal
7	P_INPUT+	Pressure reference: ± 10 Vdc maximum range (4 \div 20 mA for /I option)	Input - analog signal
8	P_MONITOR	Pressure monitor: ± 10 Vdc maximum range (4 \div 20 mA for /I option)	Output - analog signal
11	FAULT	Driver status: Fault (0Vdc) or normal working (24 Vdc)	Output - on/off signal
PE	EARTH	Internally connected to driver housing	
PS execution			
9	D_IN0	Multiple pressure PID selection	Input - on/off signal
10	D_IN1	Multiple pressure PID selection	Input - on/off signal
BC and BP execution			
9	VL+	Power supply 24 Vdc for driver's logic	Input - power supply
10	VL0	Power supply 0 Vdc for driver's logic	Gnd - power supply

Note: A minimum time of 270 to 590 ms have be considered between the driver energizing with the 24 Vdc power supply and when the pump is ready to operate; during this time the current to the valve coils is switched to zero. These connections are the same of Moog radial piston pumps, model RKP-D.

15 ELECTRONIC CONNECTIONS - 4 PIN REMOTE PRESSURE TRANSDUCER M8 CONNECTOR (only for /S and /CS options)

PIN	/S option	/CS option (Ri = 316)	/SX option (factory wired)
1	TR remote pressure trasducer feedback input (0 \div +10 Vdc)	TR remote pressure trasducer feeback (4 \div 20 mA)	
2	AGND signal zero for remote transducer power supply and feedback	NC reserved (do not connect)	
3	VT remote transducer power supply +24 Vdc	VT remote transducer power supply +24 Vdc	
4	NC reserved (do not connect)	NC reserved (do not connect)	

See tab. G465 for the pressure transducer characteristics and connections.

16 ELECTRONIC CONNECTIONS - 5 PIN COMMUNICATION M12 CONNECTOR

PIN	-PS Serial		-BC CANopen		-BP PROFIBUS DP	
	SIGNAL	TECHNICAL SPECIFICATION	SIGNAL	TECHNICAL SPECIFICATION	SIGNAL	TECHNICAL SPECIFICATION
1	NC	do not connect	CAN_SHLD	Shield	+5V	for termination
2	NC	do not connect	NC	do not connect	LINE-A	Bus line (high)
3	RS_GND	Signal zero data line	CAN_GND	Signal zero data line	DGND	data line and termination Signal zero
4	RS_RX	Valves receiving data line	CAN_H	Bus line (high)	LINE-B	Bus line (low)
5	RS_TX	Valves transmitting data line	CAN_L	Bus line (low)	SHIELD	

17 MODEL CODE OF POWER SUPPLY AND COMMUNICATION CONNECTORS

PUMP VERSION	CZ, LQZ, LZQZ	PES, PERS	-Serial (-PS) or CANopen (-BC) only for PES and PERS	PROFIBUS DP (-BP) only for PES and PERS	PRESSURE TRANSDUCER only for /S
CONNECTOR CODE	SP-666	SP-ZH-12P (1)	SP-ZH-5P (1)	SP-ZH-5P/BP (1)	SP-ZH-4P-M8 /5 (1)(2)
PROTECTION DEGREE	IP65	IP65	IP67	IP67	IP67

(1) to be ordered separately (2) M8 connector moulded on cable 5 mt lenght

VERSION CZ

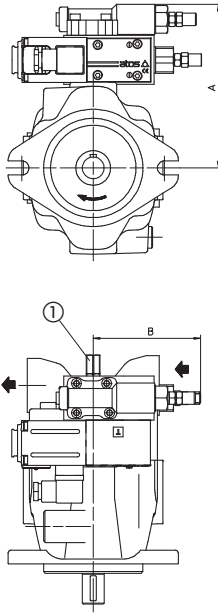

VERSION LQZ

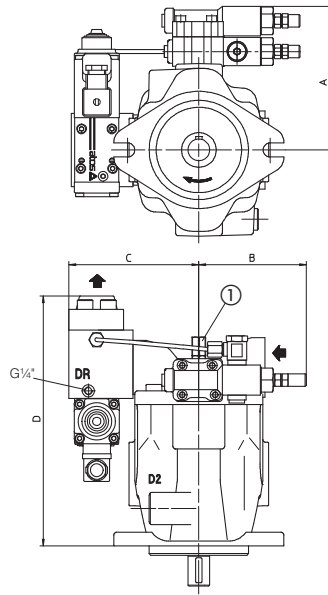

VERSION LZQZ

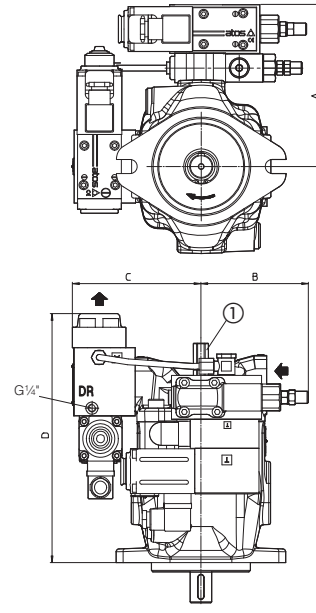

VERSION LZQZR

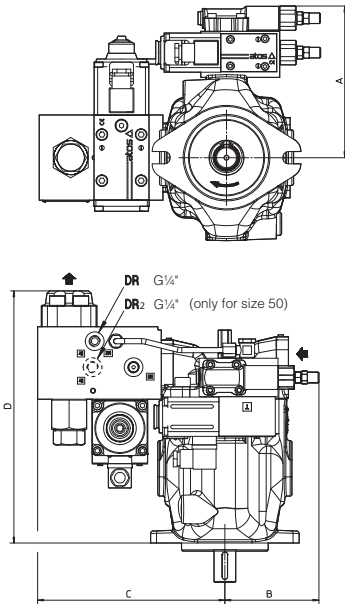

VERSION PES

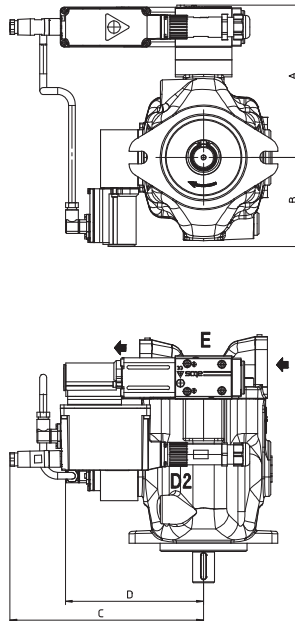

VERSION PERS
VERSION PERS/X (dotted line)

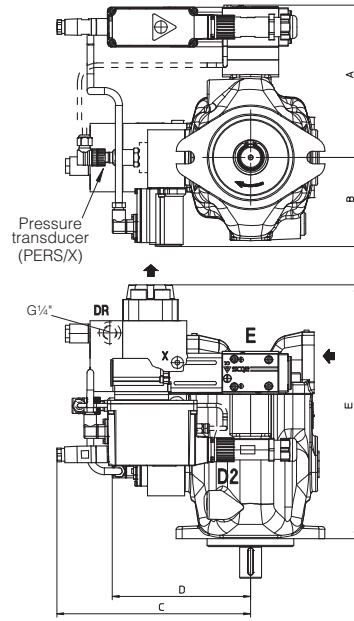

① = Regulation screw for max displacement. Adjustable range 50% to 100% of max displacement (not available for versions PES, PERS and PERS/X).
In case of double pump the regulation screw is not always available, please contact our technical office.

Drawing shows pumps with clockwise rotation (option D); pumps with counterclockwise rotation (option S) will have inlet and outlet ports inverted and consequently also the position of the control devices.

Pump type	Version	A	B	C	D	E	Mass (kg)
PVPC-*-3029	CZ	168	111	-	-	-	22
	LQZ	144	111	132	257	-	24
	LZQZ	168	111	132	257	-	27,5
	LZQZR	168	111	185	185	-	29
PVPC-*-4046	CZ	177	111	-	-	-	28
	LQZ	153	111	156	293	-	33,6
	LZQZ	178	111	156	293	-	37,4
	LZQZR	178	111	220	296	-	39,5
PVPC-*-5073	CZ	190	111	-	-	-	36,9
	LQZ	166	111	163	328	-	44
PVPC-*-5090	LZQZ	190	111	163	328	-	47,6
	LZQZR	190	111	226	328	-	49,6
PVPC-*-3029	PES	170	103,5	246	155	-	21,6
	PERS	170	103,5	246	155	262,5	26
	PERS/X	190	103,5	246	226	262,5	26,4
	PERS	178	103,5	246	162	-	27,6
PVPC-*-4046	PERS	178	103,5	246	162	299	33,7
	PERS/X	178	103,5	246	162	299	34,1
	PES	190	103,5	246	171	-	36,6
PVPC-*-5073	PERS	190	103,5	246	171	337	46,7
	PERS/X	190	103,5	246	171	337	47,1