

R4D560-AQ03-01

AC centrifugal fan

backward-curved, single-intake



Nominal data

Type	R4D560-AQ03-01		
Motor	M4D138-LA		
Phase		3~	3~
Nominal voltage	VAC	230	400
Wiring		Δ	Y
Frequency	Hz	50	50
Method of obtaining data		ml	ml
Valid for approval/standard		-	-
Speed	min ⁻¹	1365	1365
Power consumption	W	2380	2380
Current draw	A	8.65	5.0
Min. back pressure	Pa	0	0
Min. ambient temperature	°C	-40	-40
Max. ambient temperature	°C	60	60
Starting current	A	47	27

ml = Max. load · me = Max. efficiency · fa = Free air · cs = Customer specification · ce = Customer equipment
Subject to change



Technical description

Weight	27 kg
Fan size	560 mm
Rotor surface	Cast in aluminum
Impeller material	Sheet aluminum
Number of blades	9
Direction of rotation	Clockwise, viewed toward rotor
Degree of protection	IP54
Insulation class	"F"
Moisture (F) / Environmental (H) protection class	F3-1
Max. permitted ambient temp. for motor (transport/storage)	+ 80 °C
Min. permitted ambient temp. for motor (transport/storage)	- 40 °C
Installation position	Any
Condensation drainage holes	On rotor and stator sides
Mode	S1
Motor bearing	Ball bearing
Touch current according to IEC 60990 (measuring circuit Fig. 4, TN system)	<= 3.5 mA
Motor protection	Thermal overload protector (TOP) with basic insulation
With cable	Lateral
Protection class	I (with customer connection of protective earth)
Conformity with standards	EN 61800-5-1; EN 60034
Approval	EAC; VDE

AC centrifugal fan

backward-curved, single-intake

Product drawing

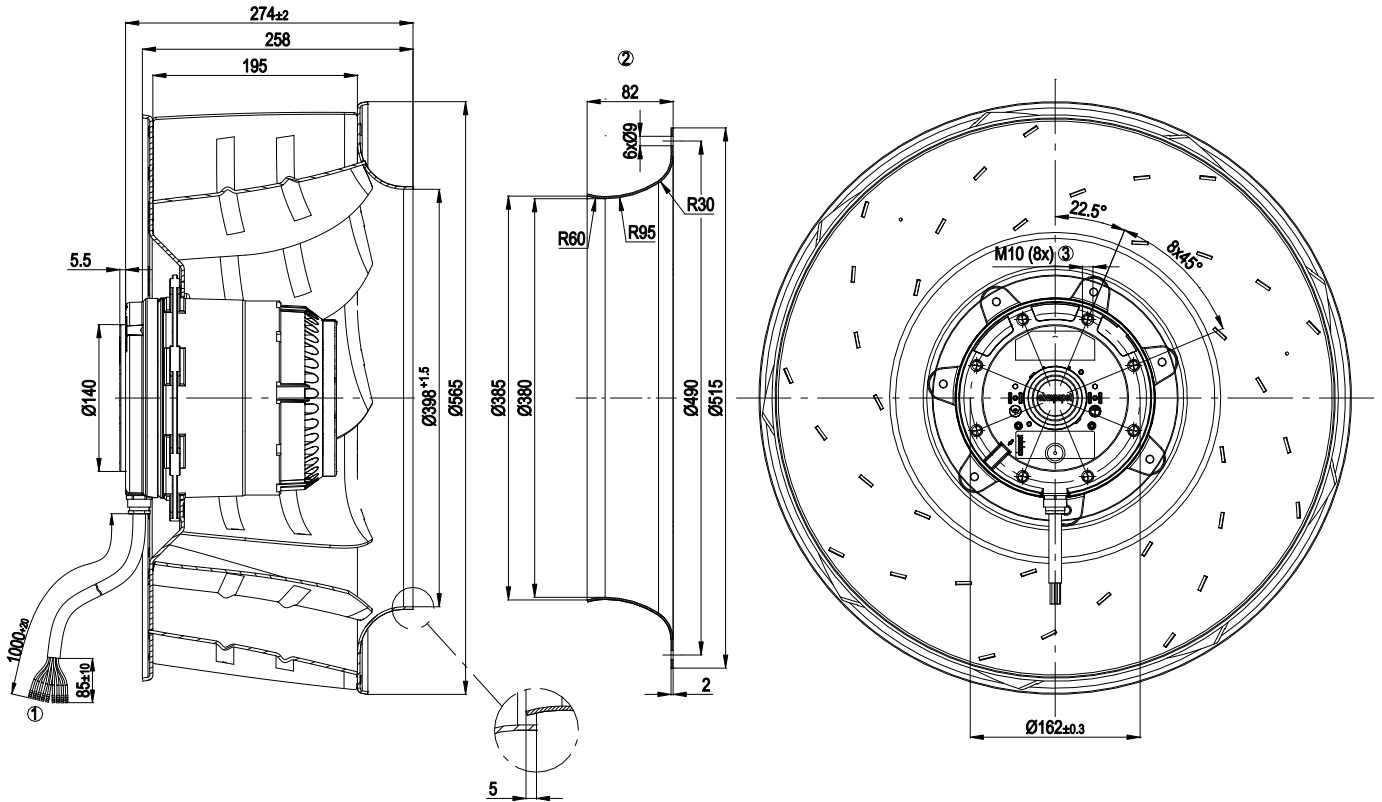

- | | |
|---|--|
| 1 | Cable halogen-free, 9 x 0.75 mm ² , 9 x crimped splices |
| 2 | Accessory part: Inlet ring 63071-2-4013 not included in scope of delivery. |
| 3 | Max. clearance for screw 18 mm |



Connection diagram

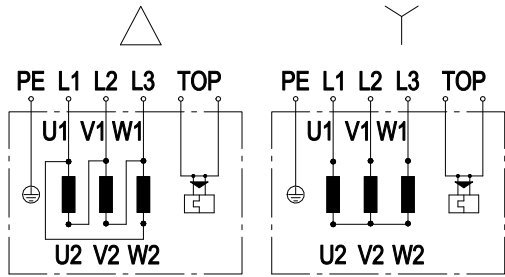

Note: Change of rotation direction by reversing two phases

Δ	Delta connection	Y	Star connection	L1	black
L2	blue	L3	brown	U1	black
V1	blue	W1	brown	U2	green
V2	white	W2	yellow	TOP	2x gray
PE	green/yellow				

Curves: Air performance 50 Hz Y

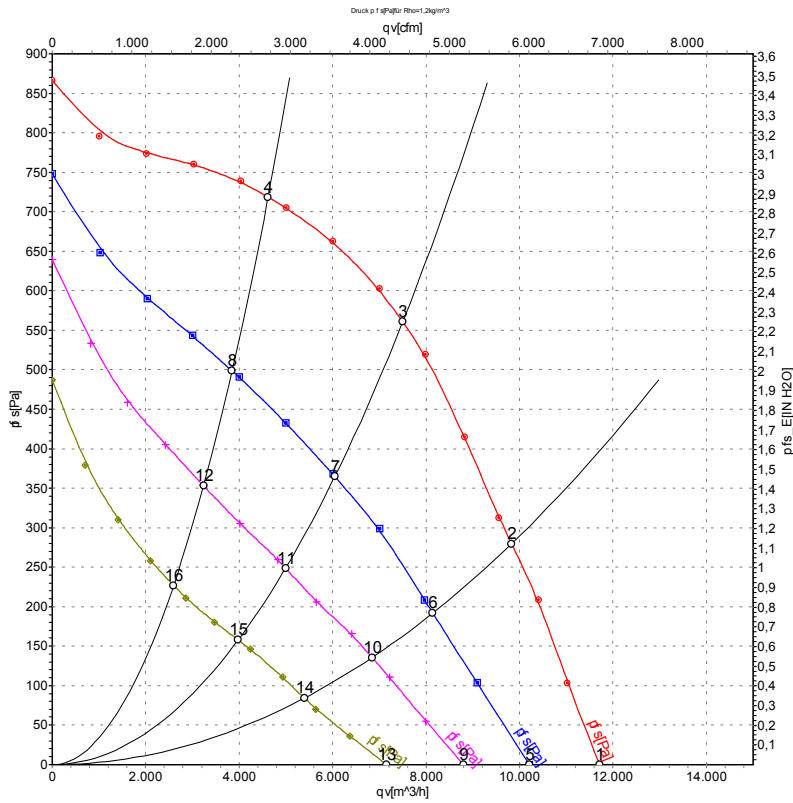

Measurement: LU-70083-1
 Measurement: LU-70117-1
 Measurement: LU-70119-1
 Measurement: LU-70120-1

Air performance measured according to ISO 5801 installation category A. For detailed information on the measurement setup, contact ebmpapst. Intake sound level: Sound power level according to ISO 13347 / sound pressure level measured at 1 m distance from fan axis. The values given are valid under the specified measuring conditions and may vary due to conditions of installation. For deviations from the standard configuration, the parameters have to be checked on the installed unit.

Measured values

	Wired	U	f	n	P _e	I	qv	P _{fs}
		V	Hz	min ⁻¹	W	A	m ³ /h	Pa
1	Y	400	50	1410	1724	4.22	11700	0
2	Y	400	50	1380	2151	4.82	9830	280
3	Y	400	50	1365	2380	5.00	7500	560
4	Y	400	50	1385	2062	4.69	4620	720
5	Y	230	50	1220	1326	4.15	10210	0
6	Y	230	50	1140	1537	4.81	8145	192
7	Y	230	50	1095	1640	5.12	6050	365
8	Y	230	50	1150	1489	4.66	3850	499
9	Y	180	50	1050	1037	4.21	8805	0
10	Y	180	50	955	1136	4.69	6845	136
11	Y	180	50	910	1184	4.88	4995	249
12	Y	180	50	970	1112	4.57	3240	353
13	Y	140	50	855	724	3.94	7150	0
14	Y	140	50	765	768	4.22	5395	84
15	Y	140	50	725	784	4.32	3980	158
16	Y	140	50	780	756	4.15	2595	227

Wired = Wiring · U = Power supply · f = Frequency · n = Speed · P_e = Power consumption · I = Current draw · qv = Air flow · P_{fs} = Pressure increase

