

FTB200 High Accuracy Turbine Flow Meter with Female Thread

- ▶ High pressure resistance
- ▶ Low pressure loss
- ▶ Fast response time
- ▶ High repeatability and accuracy
- ▶ Resistant to contamination
- ▶ Pulse / analog output selectable
- ▶ Resistant to high and low temperatures

Fluid flowing through FTB200 causes the rotor to revolve. As the rotor blade pass the pickoffs, electrical pulses are produced in which frequency is proportionai to the flow rate. The revolutions per minute and the K-factor (number of pulses/Gallon) make it possible to obtain the flow volume passing through the unit.

FTB200 series are used to measure medium or lower viscosity media, such as water,light fuel, solvent, hydraulic oil, lubricating oil etc.



Specifications

Measuring range	0.5...700L/Min
Measuring medium	Medium or lower viscosity liquids
Accuracy	Better than +1% of reading
Repeatability	+0.2% of reading
Pressure Rating	MAX.420bar
Ambient Temperature	-40...85°C
Medium Temperature	-40...120°C
Materials	
Body	304 stainless steel (316 optional)
Rotor Support	304 stainless steel (316 optional)
Turbine	stainless steel
Shaft	Hard Alloy Steel
Bearing	Hard alloy steel plain bearing
Process Connection	BSPP female thread, NPT female thread

Applications

- ▶ Petrochemical/energy industry
- ▶ Hydraulic /lubrication system
- ▶ Water treatment
- ▶ Oil / gas industry
- ▶ Experimental equipment
- ▶ Test systems

Electronics

The electronic part includes sensors and amplifiers. Selecting the appropriate sensors and amplifiers for different applications can ensure the measurement accuracy of the flowmeter. Sensors and amplifiers can be made in one piece or separate pieces according to user requirements.

Sensor

The sensor is divided into magnetic induction sensor and non-magnetic sensor. The difference between the two is that magnetic induction sensor adopts the principle of electromagnetic induction. The sensor is magnetic and will cause braking effect on the turbine at low flow rate, while non-magnetic sensor adopts the principle of carrier and the non-magnetic sensor has no influence on the turbine.

Magnetic sensor (V series) :

- Can be used for most common applications
- Measure ultra-high temperature or ultra-low temperature media (-200... 400°C)
- Applications requiring output mv signals
- When it is used for small flow, the flow range needs to be reduced (due to the nonlinear braking effect at ultra-low flow rate). When replacing the sensor, the flowmeter needs to be re-calibrated

Amplifier

The amplifier can be used in conjunction with magnetic or non-magnetic sensors, with V for magnetic sensor, R for non-magnetic sensor, and H for high temperature resistance.

VS, RS series pulse output amplifier - The output is a square wave signal, its frequency is proportional to the instantaneous.

RF series linearized frequency output amplifier - Extended measuring range and multi-point linearization, the output is square wave, optional 24V, 10V, 5V square wave, the frequency is proportional to the instantaneous flow value.

RA Series linearized analog output amplifiers - Output voltage or current models such as 0-10V, 0-5V, 0-20mA, 4-20mA, and the output value is proportional to the instantaneous flow value.

DW series intelligent amplifier - with digital display, optional analog output, alarm output, with the help of the operation menu for linearization correction, can be equipped with magnetic probe.

BT series explosion-proof intelligent amplifier - explosion-proof shell with digital display, optional analog output, communication output, alarm output, with the help of the operation menu for linearization correction, optional magnetic probe.

Bearings

Bearing is the core component of turbine flowmeter. The selection of bearing should consider whether the medium has lubricity, the measuring range of the flowmeter, the high and low temperature of the medium, etc.

Hard alloy steel plain bearings - Suitable for low lubricity or no lubricity media, smaller range ratio than the use of ball bearing flowmeters.

Dimensions inch[mm]

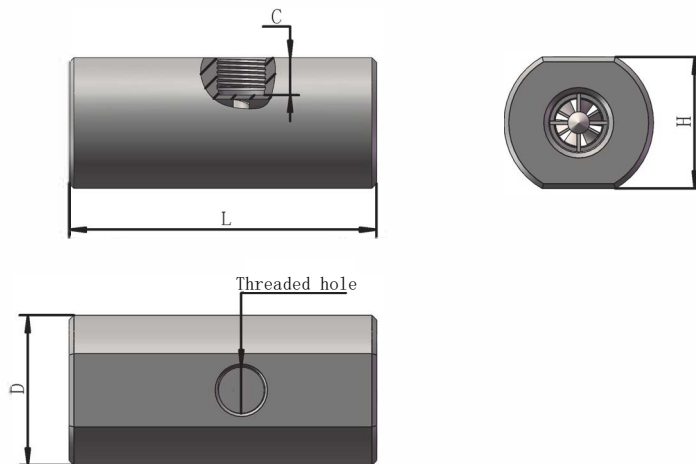

Dimensions inch[mm]

OrderNO.	L		H		D		C	
	inch	mm	inch	mm	inch	mm	inch	mm
FT2004	2.68	68	1.06	27	1.3	33	0.38	9.7
FT2006	2.68	68	1.06	27	1.3	33	0.36	9.2
FT2010	2.68	68	1.18	30	1.42	36	0.34	8.7
FT2013	3.8	96.6	1.61	41	1.85	47	0.46	11.7
FT2015	3.8	96.6	1.61	41	1.85	47	0.46	11.7
FT2020	4.53	115	1.81	46	2.05	52	0.46	11.7
FT2025	5.59	142	1.97	50	2.2	56	0.43	11
FT2032	6.46	164	2.36	60	2.6	66	0.49	12.5
FT2040	7.76	197	2.76	70	3	76	0.53	13.5
FT2050	8.27	210	2.95	75	3.26	83	0.43	11

Model Number

OrderNO.	Type	Measuring range L/Min	Extended measuring range L/Min	DN	MAX pressure Bar	Connection	Max. Filter Diameter (micron)
FT2004	FTB200GF04TCC5L	0.5—5	0.3—5	4	420	G1/4	75
FT2006	FTB200GF06TCC10L	1.0—10	0.5—12	6	420	G1/4	100
FT2010	FTB200GF10TCC20L	2.0—20	0.7—25	10	420	G3/8	150
FT2013	FTB200GF13TCC38L	3.8—38	1—38	13	420	G1/2	150
FT2015	FTB200GF15TCC68L	10—100	3—100	15	420	G1/2	150
FT2020	FTB200GF20TCC130L	13—130	5—145	20	300	G3/4	150
FT2025	FTB200GF25TCC180L	17—170	6—190	25	300	G1	200
FT2032	FTB200GF32TCC280L	25—250	9—270	32	250	G1-1/4	200
FT2040	FTB200GF40TCC350L	32—320	12—360	40	160	G1-1/2	200
FT2050	FTB200GF50TCC700L	67—670	25—700	50	150	G2	200

Optional sensor type

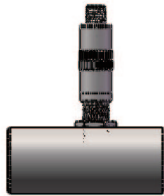

Pulse output type RS1000
VS1000

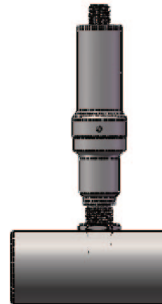

Analog output type VA1000、RA1000、KA1000
Frequency output type VF1000、RF1000、KF1000



DWE Digital display
DW1001
DW1002
DW1003

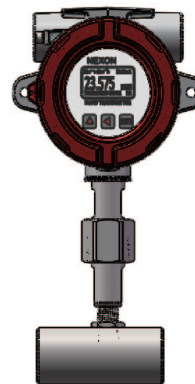

BT Explosion-proof digital display type
BT1001
BT1002