

VEGA

MODEL 2796524



RESOLVER TO SSI INTERFACE

- Works with Harowe/Danaher, Tamagawa, Kerfott, Singer, AMCI or most any Synchro/Resolver
- Makes resolvers as easy to use as an encoder
- SSI Output with 14 Bits of Turn Counts (16,384), 14 Bits of Shaft Position, and Fault Status Bit
- Excitation Frequency 2.5 kHz
- Removable Screw Terminals

With the VEGA 2796524 converter you can have both the ruggedness of a resolver and the digital simplicity of an encoder interface. The 2796524 can be used with almost any resolver. The INDEX/MARKER pulse (Channel Z) will occur once per transducer cycle at the zero degree position.

CONVERTER ACCURACY AND TRACKING RATE

The tracking rate is a function of the excitation frequency. With a 2.5 kHz excitation the tracking rate would be 9,600 rpm.

2796524 SPECIFICATIONS

Excitation:	2.5 kHz @ 3.6 vpp
Resolver Input:	0.8 to 18 vpp
Power Requirements:	5 vDC @ 250 mA (2796524.05) 24 vDC @ 125 mA (2796524.24)
Drive Capacity:	200 mA Peak
Mechanical:	4.10 x 0.75 x 5.00
Accuracy:	+/- 3 arc minutes typical.

RESOLVER TO SSI CONVERTER WITH 14 BIT TURN COUNTER, 14 BIT RESOLUTION, AND FAULT BIT

*** APPLICATIONS ***

- Ideal For Closed Loop Positioning Systems
- Machine Tools
- Nuclear Applications
- PLC Positioning Control
- Index/Rotary Tables
- Tracking/Telescope/Telemetry Systems
- Transfer Lines
- Positioning Systems
- Robotic Applications
- Dispensing Systems

*** ADVANCED FEATURES ***

- Incremental Encoder Output (*Absolute within 1 Resolver cycle)
- Non-Phase Locked Loop Design for Faster Loop Closure
- High Resolution and Highly Accurate
- Tuned Filter for Noise Immunity
- A-Quad-B, Index and Complements
- TTL/Line Driver Outputs
- Quadrature encoder signals to 4 mHz
- Single vDC Supply Operation
- Loss of Phase Detection
- Fault Signal Output (Line Driver, and Active Pull-Up)
- Status LED's for Power, A, B, Z, Signal HI, Signal MID, and Fault
- Configurable Fault signal conditioning for Fail-Safe operations
- Compact Design Only 17.5 mm wide

* Tracking limited to +/- 0.25 Resolver cycle with power off

SSI (Synchronous Serial Interface)

The 2796524 Resolver to Digital Converter has a differential SSI interface for applications requiring serial interface. This makes the 2790524 IDEAL for applications where absolute multi-turn resolver feedback is required.

PART NUMBER AND DESCRIPTION

Model	Description
2796524.05	+5 vDC Resolver to SSI
2796524.24	+24 vDC Resolver to SSI

SSI (Synchronous Serial Interface)

The 2796524 board's SSI interface provides serial transmission of absolute position data in binary form from the resolver based on a timed clock pulse train from the host device. The SSI differential interface provides a high degree of noise immunity. For each sequential clock pulse from the host device, the 2796524 board transmits one data bit from the shift registers of the tracking circuit.

Applying 5-25 vDC to P3-9 will preset the SSI turn counter to 8192 and the low order data will reflect the current shaft position of the resolver.

SSI TIMING DIAGRAM

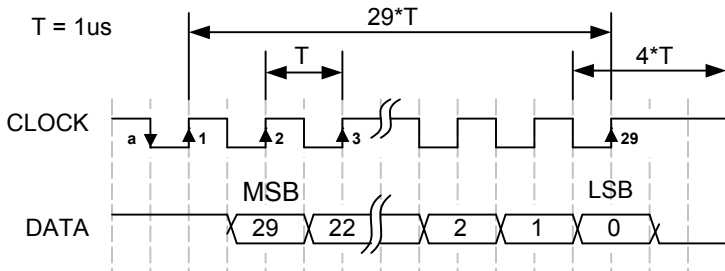

- 1) The 2796524 SSI Format is set up for 29 bit transfers.
- 2) The 2796524 uses the least significant 14 bits for positional data (16384 counts per rev), and the next 14 most significant bits are used for the turn counter. During a fault detection the contacts of the solid state relay between P1-8 and P1-9 will also be opened.
- 3) Data is available less than 100ns after the down clock transition and well ahead of the up clock transition at 1mhz clock frequency. The data should be sampled at the up transition of the clock.
- 4) The 2796524 is normally interrogated 1000 times/sec.
- 5) The Galil motion control board setup string would be: **SIX=1,29,14,0<-10>1.**
- 6) The Galil command **MG_SIX** will sample the Fault status bit.

QUADRATURE OUTPUT

The VEGA 2796 series of converter boards use RS-422-A differential drivers to provide 40 mA into a 100 ohm differential load. These outputs are also TTL compatible.

The output latency is dependent on the excitation frequency. At 2.5 kHz the response will be less than 200 uSec and at 10.0 kHz the response will be less than 50 uSec.

Quadrature is provided via Channel A+, Channel A-, Channel B+ and Channel B-. A count is considered to occur whenever there is a transition in either the Channel A or Channel B output signals. The Channel Z (Index) occurs once per resolver cycle. The phase relationship of the two signals indicates the direction of motion as shown in the figure below.

QUADRATURE OUTPUT FORMAT

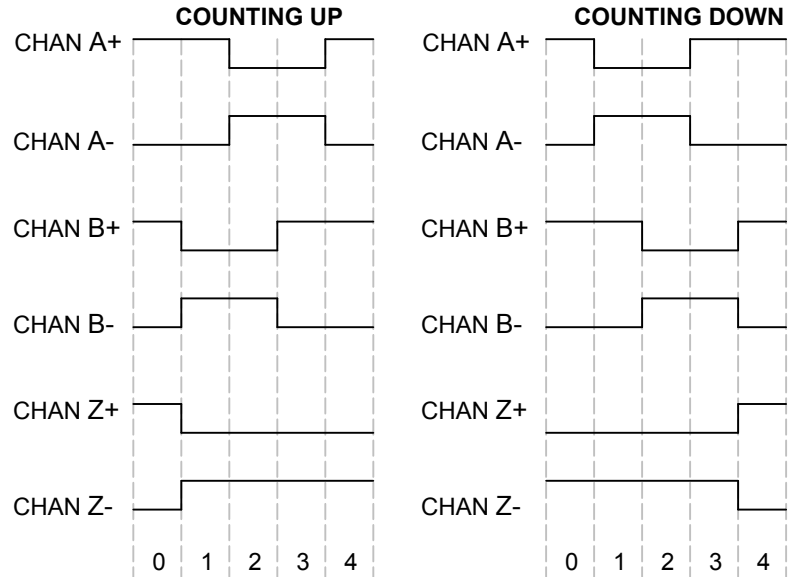

P1 POWER CONNECTOR

PIN#	FUNCTION	COLOR
1	+5 vDC IN (2796524-05 Only)	RED
2	DC Ground	BLK
3	Shield In	SHLD
4	No Connection	N/A
5	No Connection	N/A
6	No Connection	N/A
7	No Connection	N/A
8	!Fault Output	ORG
9	I/O vDC IN	BLU/WHT
10	+24 vDC IN (2796524-24 Only)	BLU

P2 ENCODER CONNECTOR

PIN#	FUNCTION	COLOR
1	Channel A+	Grey
2	Channel A-	Violet
3	Channel B+	Yellow
4	Channel B-	Orange
5	Channel Z+	Blue
6	Channel Z-	Green
7	Shield Out	SHLD
8	No Connection	N/A
9	No Connection	N/A
10	No Connection	N/A
11	No Connection	N/A
12	No Connection	N/A
13	No Connection	N/A

P3 SSI CONNECTOR

PIN#	FUNCTION	COLOR
1	No Connection	N/A
2	No Connection	N/A
3	Shield Out	SHLD
4	DC Ground OUT	N/A
5	SSI Clock-	RED/WHT
6	SSI Clock+	RED
7	SSI Data-	BLUE/WHT
8	SSI Data+	BLUE
9	SSI Preset	YELLOW

P4 RESOLVER CONNECTOR

PIN#	FUNCTION	COLOR
1	Feedback LO	YEL/WHT
2	Feedback HI	RED/WHT
3	Shield Out	SHLD
4	Sine LO	BLACK
5	Sine HI	RED
6	Shield Out	SHLD
7	Cosine HI	YELLOW
8	Cosine LO	BLUE
9	Shield Out	SHLD
10	No Connection	N/A
11	No Connection	N/A

JUMPER SETTINGS (JB1)

FREQUENCY SELECTION (JB1-1 & JB1-2)

The 2796 converters provide a fixed excitation frequency of 2.5 kHz both JB1-1 and JB1-2 jumpers should be removed.

SSI Preset (JB1-3)

Momentarily Installing JB1-3 jumper will preset the turn count to 8192.

RESERVED (JB1-4 thru JB1-9)

On the 2796524 converter board Jumpers JB1-6 thru JB1-9 are reserved and should have all jumpers removed

ACTIVE FILTER SELECTION (JB1-10)

The 2796 also provides jumper selection of the active filter network for the return signal to provide the maximum noise immunity at the selected frequency. For the typical Resolver application operating at 2.5 kHz JB1-10 jumper should be installed. For excitation frequencies above 2.5 kHz JB1-10 jumper should be removed.

INTERNAL GAIN SELECTION (JB1-11 & 12)

The 2796 series of converters provide selectable gain selection via JB1 jumpers 11 and 12. Installing a jumper on JB1-11 selects a gain of x0.25 Installing a jumper on JB1-12 selects a gain of x1.0 and removing the jumpers JB1-11 and JB1-12 selects a gain of x4.0

See Figure 1.0 for JB1 Jumper Chart Below.

THEROY OF OPERATION

The return signal level is monitored for high signal level (HSG LED), and low signal level (FLT LED). During a low level detection or loss of power to the board the fault relay contacts will open (connector P2 terminal 8 and 9). The A-Quad-B outputs will be tri-stated during a fault detection.

The Z channel (Marker Pulse) will occur once per resolver cycle (resolver pole pair) and will occur around 90 degrees from the sine excitation. The Z channel (Marker Pulse) will occur once per resolver cycle (resolver pole pair).

POWER UP SEQUENCE

- 1) The 2796 allows 50 mSec for the power to stabilize
- 2) The 2796 then starts the Sine and Cosine excitations with the sine being in sync with the command square wave
- 3) The 2796 will then initialize the A-Quad-B outputs with channel A and B active (high state) and the Z channel (index/marker) to inactive (low state).
- 4) The 2796 will then interpolate out A-Quad-B counts to the nearest resolver null to indicate absolute shaft position

FAULT SIGNAL INTERFACE

The return signal level is monitored for high signal level (HI LED), and low signal level (LO LED). During a low level detection or loss of power to the board the fault relay contacts will open (P1-8 and P1-9). The relay can drive 600 mAmps. The source voltage must be provided on P1-9 and can range from 5-25 vDC.

During fault detection the A-Quad-B outputs will also be tri-stated, and the SSI fault bit will be set to a high level.

FUNCTION	1	2	3	4	5	6	7	8	9	10	11	12	QUADRATURE COUNTS
2.5 kHz Excitation	0	0											
Reserved	1	0											
Reserved	0	1											
Reserved	1	1											
SSI Preset			0										
Reserved				0	0	0	0	0	0				
10.0 kHz LPF										0			
2.5-5.0 kHz LPF										1			
x 4.0 Gain Select											0	0	
x 0.25 Gain Select											1	0	
x 1.0 Gain Select											0	1	
Reserved											1	1	

Figure 1.0

Indicates Default

RESOLVER SET-UP PROCEDURE

- 1) With the power turned off. Install the 2796 board as described in the application drawing and complete the following steps.
- 2) Jumpers JB1-4 through JB1-9 are reserved on the 2796524 board and should be removed
- 3) Select the passive filter setting by JB1-10 for the corresponding frequency setting. The DEFAULT setting is set to 10.0 KHZ and JB1-10 is removed.
- 4) Select the Internal Gain Selection by setting the JB1-11 and JB1-12 jumpers as described in the JUMPER SETTINGS section. The DEFAULT setting is for a board set to x1 Gain JB1-12 installed (See step 8 for detailed set-up instructions).
- 5) Starting with the JB1-11 jumper removed and the JB1-12 jumper installed (x1.0 Gain Selection). Turn the ADJ Potentiometer fully counter-clockwise (12 turn Pot). Observing the LO, MID and HI LEDs apply power to the board.

NOTE: If the MID or HE LEDs are turned on, remove JB1-12 and install JB1-11 (x0.25 Gain Selection).

- 6) Turn the ADJ potentiometer clock-wise until the (Green) MID LED turns on and the LO LED turns off. Continue turning the ADJ clock-wise until the HI LED turns on. Now turn the ADJ potentiometer counter-clockwise to position the ADJ in the middle of the MID LED band.

NOTE: If you are unable to get the MID or HI LED to turn on, remove both JB1-11 and JB1-12 jumpers (x4.0 Gain Selection).

- 7) Turn the ADJ potentiometer clock-wise until the (Green) MID LED turns on and the LO LED turns off. Continue turning the ADJ clock-wise until the HI LED turns on. Now turn the ADJ potentiometer counter-clockwise to position the ADJ in the middle of the MID LED band.

NOTE: If you are unable to get the MID or HI LED to turn on, remove both JB1-11 and JB1-12 jumpers (x4.0 Gain Selection).

Phase the position loop if necessary by reversing the Sine HI and Sine LO wires to reverse the count direction. At this point the basic set-up is complete and the position loop can now be closed.

- 8) The amplitude balance of the Sine and Cosine excitations, have been factory set and should not require adjustment. To adjust the phase balance of the 2796 board, observe the excitation return on the "ST1" test point. Adjust the oscilloscope to 50 mvDC per division and offset the signal so that just the peak of the signal is visible. Rotate the resolver at 500-600 rpm. If the phase is unbalanced the peak of the sine wave will bounce and become blurred. Adjust the balance pot on the 2796 to achieve 20 mvDC or less bounce.

TEST POINTS

- ACOM** = Analog Ground
PA+ = Sine HI (3.6 vDC Peak to Peak)
PA- = Sine LO (3.6 vDC Peak to Peak)
PB+ = Cosine HI (3.6 vDC Peak to Peak)
PB- = Cosine LO (3.6 vDC Peak to Peak)
SIG = Signal Return (0.8-18.0 vDC Peak to Peak)
ST1 = Stage 1 Signal (3.8 vDC Peak to Peak)

LED STATUS INDICATORS

- CHA** = Channel A State Indicator
CHB = Channel B State Indicator
CHZ = Channel Z (Index/Marker) Indicator
PWR = Power Status Indicator
- FLT** = 1 Flash = Low Signal Continuous
2 Flash = High Signal Continuous
3 Flash 2796512 Only
PUPV Fault (Power Up Position Valid)
Power up position detected +/- 15 Counts of Error
4 Flash = Low Signal Intermittent
5 Flash = High Signal Intermittent
- LO** = Loss of Signal Indicator
MID = Return Signal Proper Indicator
HSG = High Signal Indicator



TROUBLE SHOOTING

SYMPTOM	CHECKS	SOLUTION
No Power LED	Check +5 vDC on 2796524-05 or +24 vDC on 2796524-24	vDC Present → Board Failure – Replace board
LO LED (Low Signal) Continuous	Remove power and disconnect P4 from the board. Ohm the wires on P4-1 and P4-2 and note value.	Resistance values are less than 30 ohms – Check for shorts between P4-1 and P4-2 as well as ground.
	Remove power and disconnect P4 from the board. Ohm the wires on P4-4 and P4-5 and note value. Ohm the wires on P4-7 and P4-8 note value.	Resistance values are less than 30 ohms – Check for shorts between P4-4 and P4-5 as well as ground. Check for shorts between P4-7 and P4-8 as well as ground.
	Apply power and measure between P4-4 and P4-5 for 2.9 vRMS	Signal not present → Board Failure – Replace board
	Apply power and measure between P4-7 and P4-8 for 2.9 vRMS	Signal not present → Board Failure – Replace board
	Check “ST1” test point for 3.6 volts peak to peak	Repeat Step 7 of the Resolver Set-Up Procedure
LO LED (Low Signal) Intermittent	Remove power and disconnect P4 from the board. Ohm the wires on P4-4 and P4-5 and note value. Ohm the wires on P4-7 and P4-8 note value.	Resistance values differ by more than 3 ohms of each other → Check resolver windings – Replace cables and/or resolver
	Check “ST1” test point for bounce	Repeat step 8 of the Resolver Set-Up Procedure
Cyclic Error	Check “ST1” test point for bounce	Repeat step 8 of the Resolver Set-Up Procedure
	Remove power and disconnect P4 from the board. Ohm the wires on P4-4 and P4-5 and note value. Ohm the wires on P4-7 and P4-8 note value.	Resistance values are less than 30 ohms – Check for shorts between P4-4 and P4-5 as well as ground. Check for shorts between P4-7 and P4-8 as well as ground.
	Remove power and disconnect P4 from the board. Ohm the wires on P4-4 and P4-5 and note value. Ohm the wires on P4-7 and P4-8 note value.	Resistance values differ by more than 3 ohms of each other → Check resolver windings – Replace cables and/or resolver
HSG LED (High Signal) Continuous	Check “ST1” test point for 3.6 volts peak to peak	Repeat Step 7 of the Resolver Set-Up Procedure
HSG LED (High Signal) Intermittent	Check “ST1” test point for 3.6 volts peak to peak	Follow procedures described in the LO LED (Low Signal) Intermittent section
MID LED (Signal Midpoint) Continuous	Signal Proper	No Problem... Life is Good
MID LED (Signal Midpoint) Intermittent	Check “ST1” test point for bounce	Repeat step 8 of the Resolver Set-Up Procedure
Feedback Polarity is Reversed	None	Swapping the P4-4 (Sine HI) with the P4-5 (Sine LO) wires will reverse the feedback polarity

APPLICATION INTERFACE

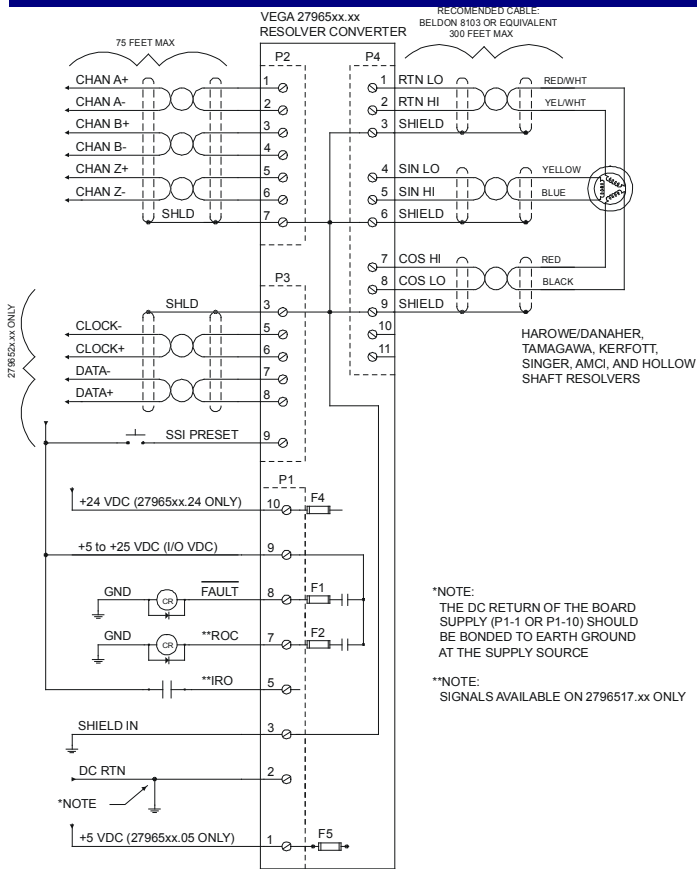

DISASSEMBLY

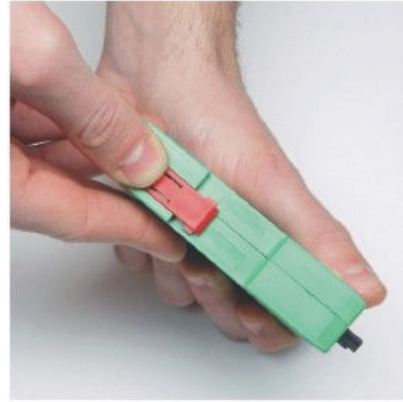

Firmly press the center of the latch hook down and slide towards the center of the enclosure.

NOTE: Use caution not to drop the spring under the latch hook.

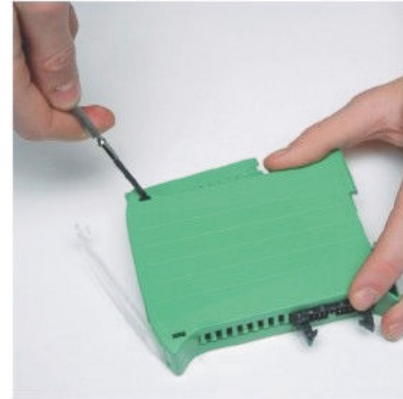

Using a small flat head screwdriver release all four of the enclosure cover hooks.

NOTE: Use caution to avoid breaking the cover hooks.

MECHANICAL

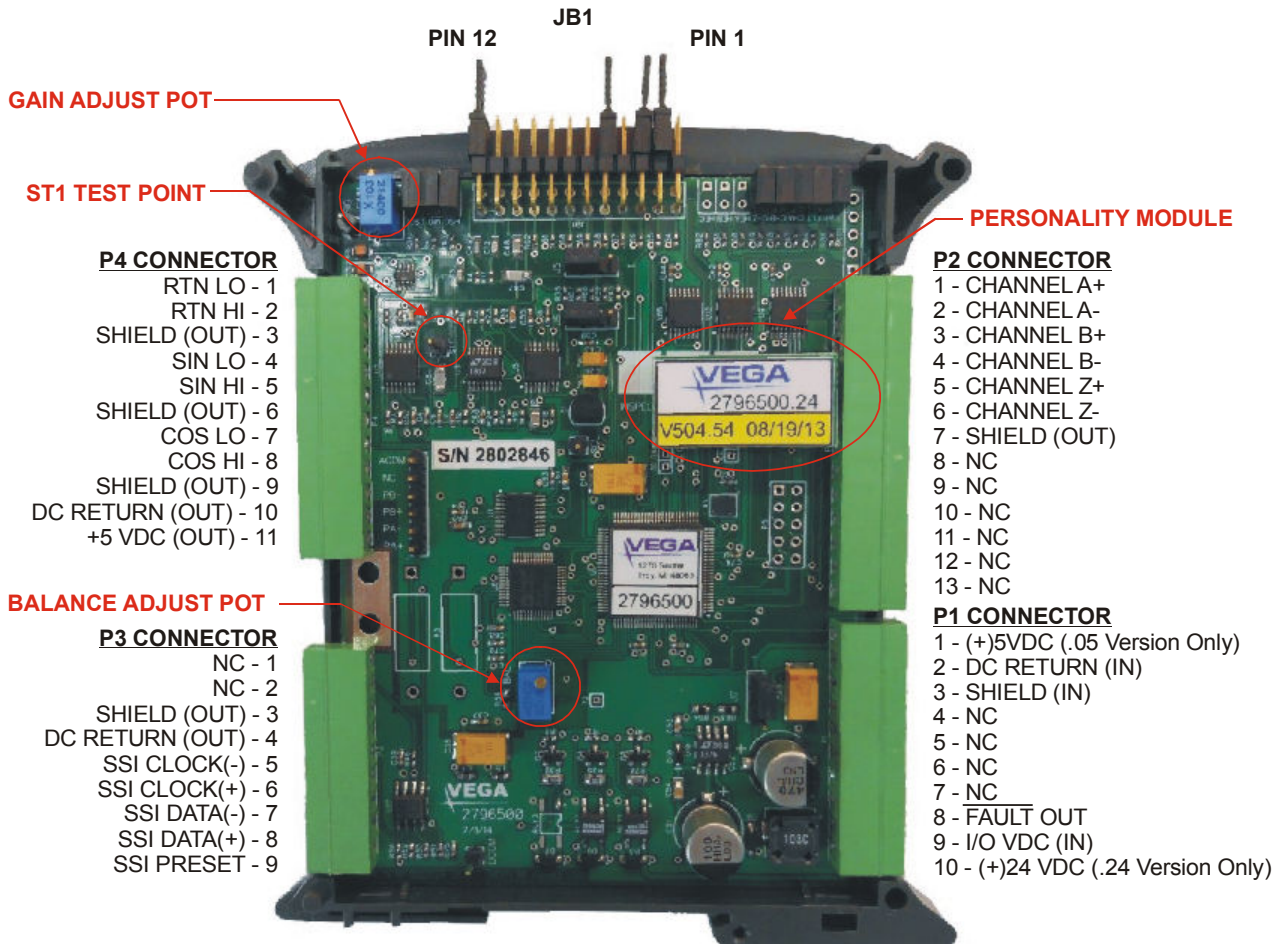

POWER REQUIREMENTS

The 2796524-05 converter requires +5 vDC supply @ 250 mAmp for operation. The 2796524-24 converter requires +24 vDC supply @ 125 mAmp for operation. The supplied power should have less than 50 mVolts of noise and drift.

Recommended Power Supplies (If Required)

TDK DSP30-5 (+5 vDC @ 3 Amps)

TDK DSP60-24 (+24 vDC @ 2.5 Amps)

CABLE SPECIFICATIONS

The 2796 series of converters provide stable and precise sine and cosine excitations. These signals and the return signal are analog and proper routing and shielding techniques should be observed. Shielded twisted pair cables should be used for all interface signals.

Recommended Cable

Shielded (3) Twisted Pair with Drain Wire
Belden #8103 or equivalent



**12974 Jewell Circle NE
Blaine, MN 55449
248.585.3600**

Monday-Friday 8:00am to 6:00pm Central