

## CONVENTIONAL DETECTOR BASES

### NS6 AND NS4 SERIES BASE



NS Series Bases	Alarm Current	ID
NS6-224 OR NS4-224	43mA (70mA @ 33.0V MAX)	HB-5
NS6-220 OR NS4-220	93mA (136mA @ 33.0V MAX)	HB-3
NS6-221 OR NS4-221	46mA (77mA @ 33.0V MAX)	HB-4
NS6-100* OR NS4-100*	150mA @ 15.0-33.0V MAX	HB-55

\* Requires external current limiting to 150mA maximum

### HSC-(X)R RELAY BASE & HSC- 4R 4 WIRE BASE



2 Wire Auxiliary Relay Bases	Alarm Current	ID
HSC-224R	43mA (58mA @ 30.0V MAX)	HB-73
HSC-220R	88mA (98mA @ 26.5V MAX)	HB-72
HSC-221R	49mA (62mA @ 30.0V MAX)	HB-71

4 Wire Base	Alarm Current	ID
HSC-4R	43mA (58mA @ 30.0V MAX)	N/A

The NS6 and NS4 series bases are designed specifically for use with Hochiki's conventional models:

- Photoelectric smoke detectors: SOE-24V, SOE-24H, SOC-24V, SOC-24VN, SLR-24V, SLV-24, SLV-24N, SLV-24V, SLR-835, SLR-24H
- Photoelectric with heat smoke detector: SLR-835H
- Fixed temperature/rate-of-rise heat detector: DCD-135/190

The NS6 base is an electronics free 6" base featuring a plastic tamper-lock lug. Each base is equipped with a resistor. Please refer to the chart (left) for additional specifications. The NS4 base is a 4" version of the NS6 base.

Models HSC-224R, HSC-220R and the HSC-221R are designed specifically for use with the Hochiki conventional models SOE-24V, SOE-24H, SOC-24V, SOC-24VN, SLR-24H, SLR-24V, SLV-24, SLV-24N, SLV-24V, SLR-835, SLR-835H, DCD-135/190. The HSC-(X)R series is a 6" base with two sets of Form "C" relay contacts.

Models HSC-224R, HSC-220R and the HSC-221R are also approved for use with Hochiki's previous conventional model DFE 135/190.

The HSC-4R is designed specifically for 24 volt 4 wire applications using Hochiki conventional models SOE-24V, SOE-24H, SOC-24V, SOC-24VN, SLR-24H, SLR-24V, SLV-24, SLV-24N, SLV-24V, SLR-835, SLR-835H or DCD-135/190. The 6" diameter base is current limited. Relay contact place a direct short circuit across the loop when the detector is actuated.

Model HSC-4R is also approved for use with Hochiki's previous conventional model DFE 135/190.

Bases are available in bone or white to match the detector. Bone (off-white) is the standard color for detectors and bases for most applications.

BASE	BOX MOUNTING		
	3" OCT	4" OCT	4" SQR
NS4-BASE	YES	NO	NO
NS6-BASE	NO	YES	YES
HSC-BASE	NO	YES	YES

#### PRODUCT LISTINGS



California State  
Fire Marshal  
7300-0410-0132

We try to keep our product information up-to-date and accurate. However, we cannot cover all specifications or anticipate all requirements. For additional information contact your local distributor or Hochiki America Corporation.

## CONVENTIONAL DETECTOR BASES

### NS4 AND NS6 SERIES BASE

#### 2-WIRE OPERATION

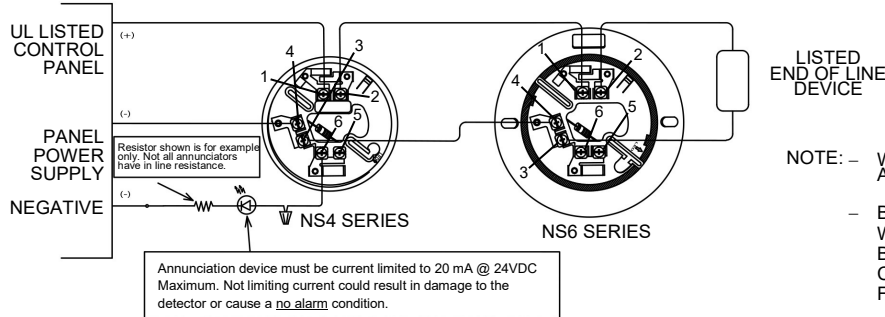

### HSC-(X)R RELAY BASE

#### 2-WIRE OPERATION

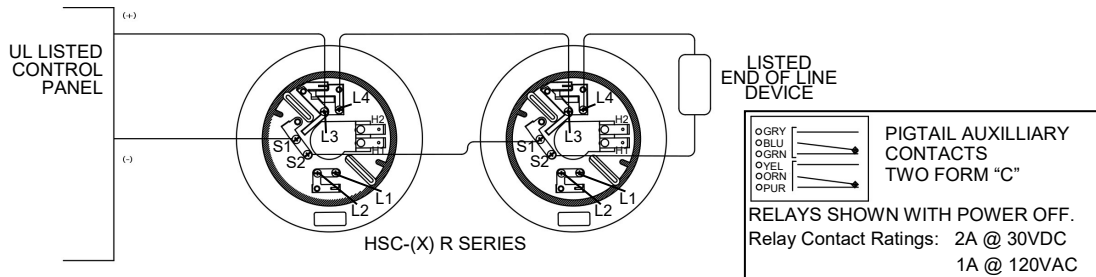

### HSC-4R FOUR WIRE BASE

#### 4-WIRE OPERATION

