

## INSTRUCTION MANUAL MODEL TSA TENSION SENSOR AMPLIFIER

All of the information herein is the exclusive proprietary property of Maxcess International, and is disclosed with the understanding that it will be retained in confidence and will neither be duplicated nor copied in whole or in part nor be used for any purpose other than for which disclosed.

Copyright 2004, all rights reserved.

### 1.0 Introduction

The MAGPOWR Model TSA is a Tension Sensor Amplifier. The TSA supplies 10 vdc or 5 vdc excitation for both full bridge or half bridge tension sensors. The signals from the tension sensors are added together and amplified to produce a 0 to 10 vdc or a 4 to 20 mdc output.

### 2.0 Mounting

The TSA is intended for installation on a vertical panel with a DIN 35 rail, with the wiring terminals facing down. Figure 1 shows the enclosure dimensions.

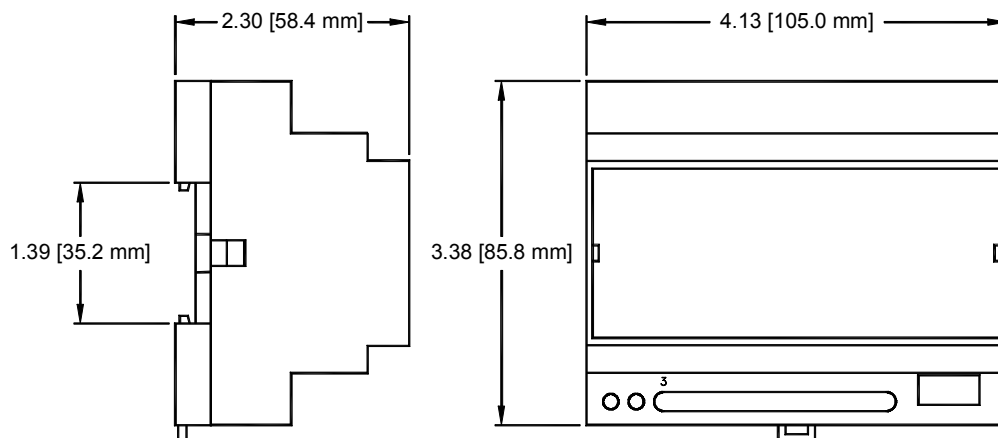
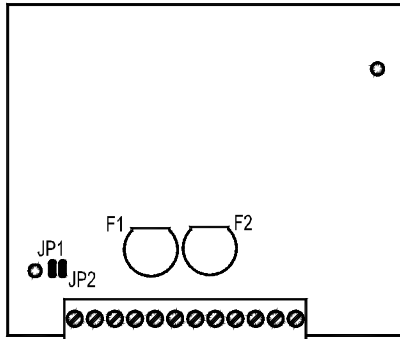

Figure 1  
Enclosure Dimensions

### 3.0 Setup

When Magpowr, or other 21 mv tension sensors are used, no setup is necessary. If 500 mv tension sensors are used, then JP1 and JP2 must be cut (See figure 2). The enclosure may be opened by inserting a flat blade screwdriver under one of the retaining tabs in the base and lifting the cover (See figure 3).



**Figure 2**  
Location of JP1 & JP2

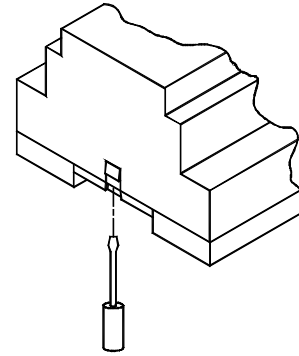

**Figure 3**  
Enclosure Top Removal

#### 4.0 Electrical Connections

Figure 4 shows the wiring connections that are required for the basic system. They are:

- 115/230 vac power cable
- Tension Sensor cables
- Output cable
- Meter cable

Wiring to and from the TSA must be done with double reinforced insulation or protective screening which provides protective separation. All wiring should comply with the essential requirements of the appropriate standard(s) and is the responsibility of the installer.

Route AC power away from sensor wiring. Run all wiring in shielded cable. Connect shields to the terminals indicated as "SHIELD". Maximum shield length and maximum length of wires outside of the shield is 3 in. (75 mm).

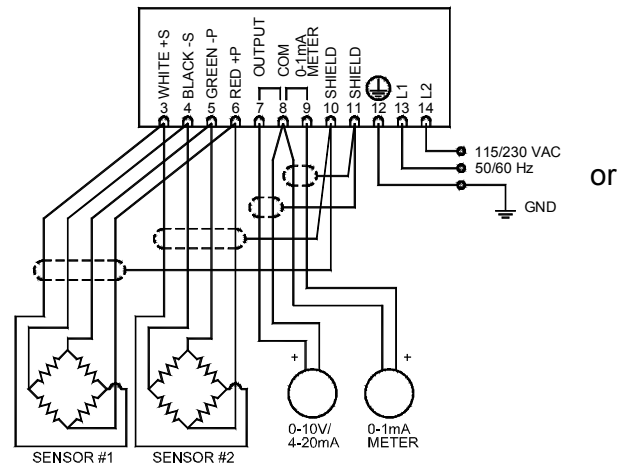

**Figure 4**  
Wiring Connections

#### 5.0 Maintenance

The only maintenance that may be required on the TSA is fuse replacement. Replacement of the fuse(s) requires first removing AC power, then opening the enclosure, which circumvents the enclosure IP rating. The enclosure may be opened by inserting a flat blade screwdriver under the retaining tabs in the base (See figure 3).

#### 6.0 Calibration

Use the "SELECT OUTPUT" switch to choose the desired tension reference output. There are two choices, 0 to 10 vdc or 4 to 20 mdc.

Tension reference output calibration is accomplished by two adjustments (**ZERO** and **GAIN**). The **ZERO** adjustment is used to cancel the weight of the sensing roll. The **ZERO** adjustment will adjust out a sensing roll weight of up to 50% of the sensor(s) load rating(s).

## 6.0 Calibration Continued

After suspending a known weight with a temporary web (See figure 5), adjust **GAIN** until the desired tension reference output is reached. The maximum load on the sensors must be less than or equal to the total sensor rating and greater than 1/8 of the total sensor rating. When two sensors are used the total sensor rating is the combined rating of both sensors (i.e. 100 lb for two 50 lb sensors).

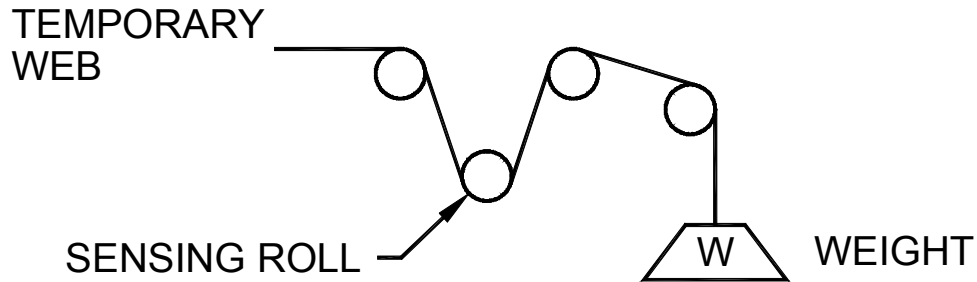

**Figure 5**  
**Dead Weight Calibration**

## 7.0 Troubleshooting

PROBLEM	DIAGNOSTIC
Cannot ZERO the meter	<ol style="list-style-type: none"> <li>1) The total weight of the sensor idler roller and shaft must be less than <math>\frac{1}{2}</math> of total sensor rating. When two sensors are used this is the combined rating of both (i.e. 100 lb for two 50 lb sensors).</li> <li>2) Verify "SELECT OUTPUT" switch set for the appropriate tension reference output.</li> <li>3) Verify tension sensors cables are connected correctly to the TSA.</li> <li>4) Verify JP1 and JP2 are set correctly for the tension sensor(s) being used.</li> </ol>
GAIN adjustment does not give the desired output	<ol style="list-style-type: none"> <li>1) Calibration load is greater than the sensor(s) rating.</li> <li>2) Verify 115/230 vac power select switch is set to the appropriate voltage.</li> <li>3) Verify "SELECT OUTPUT" switch set for the appropriate tension reference output.</li> <li>4) Verify tension sensors cables connected correctly to the TSA.</li> </ol>

<p>GAIN adjustment does not give the desired output (Continued)</p>	<p>5) Verify JP1 and JP2 are set correctly for the tension sensor</p> <p>6) The impedance load on the output is not within specifications (0 to 10 vdc - 10 kohm min.) (4 to 20 madc - 500 ohm max. )</p>
---	---

### 8.0 Specifications

Supply Voltage:	115/230vac, +/- 10%, 50/60 Hz, Switch selectable
Fuses: F1, F2	1.6 amp, Littelfuse Part No. 21601.6, or Wickmann Part No. 19194-053-FS
Enclosure:	IP20
Climatic Class:	3K3 (EN60721)
Temperature Range:	
Operating:	0° C to 50° C
Storage:	-30° C to 80° C
Relative Humidity:	5% to 85%
Pollution Degree:	2 (IEC664-1)
Altitude:	0 to 2000 m
Compatible Residual Current Device Types:	A or B (IEC755)
Worst Case Fault Current:	1.6 amp ac
Sensor Excitation:	5 or 10 vdc, 64 madc maximum
Tension Sensor Input:	0 to 21 mv or 0 to 500 mv, jumper selectable
Outputs:	
Tension Reference Output:	0 to 10 vdc or 4 to 20 madc
Meter Signal:	0 to 1 madc



MAXCESS INTERNATIONAL COMPANIES



GUIDING · INSPECTION



TENSION CONTROL



SLITTING · WINDING