

OVERVIEW

Metrix 440 and 450 electronic vibration switches provide economical, self-contained, single-channel vibration protection. The 440 switch is suitable for use in non-hazardous as well as Class I Div 2 hazardous areas. The 450 switch utilizes the same internal electronics as the 440, but features explosion-proof enclosure styles suitable for Class I Div 1, Class II Div II, and Class III hazardous areas.

Options are available for electronic (triac or FET) or electro-mechanical relay outputs, allowing the switch to be used in an auto-shutdown circuit that trips the machine under high vibration conditions. SR versions provide a single alarm setpoint and corresponding discrete output. DR versions provide two independent alarm setpoints and corresponding discrete outputs, allowing implementation of ALERT (pre-shutdown) and DANGER (shutdown) levels. A separate 4-20 mA proportional output is also provided on all switch models, allowing connection to PLCs, DCSs, strip chart recorders, or other process control systems where vibration levels can be trended.

Vibration on both switches is monitored in RMS velocity units. The standard configuration consists of an internal accelerometer mounted inside the switch housing, providing completely self-contained functionality. The switch may also be configured to use an external accelerometer if desired.*

* **NOTE:** Hazardous area approvals are not available when an external sensor is used with the model 440. Consider models 450 or SM6100 instead, which are approved for use in hazardous areas with a variety of external sensor types when Metrix sensor housing 7295 and explosion-proof wiring practices are used.

APPLICATIONS

Vibration switches are an attractive solution when all of the following criteria apply:

- Only one or two measurement points are required on a machine.
- A fully self-contained approach is desired or required (sensing element, signal conditioning, alarming, and outputs).
- Sufficient room exists to mount a vibration switch on the machine in the correct location and in the correct orientation such that the vibration levels indicative of machinery malfunctions will actually be measurable at the switch mounting location.
- The features of a multi-channel monitoring system are not necessary and cannot be financially justified.
- A 4-20mA vibration transmitter is undesirable or impractical because a PLC, DCS, SCADA system, or other instrumentation is not available for monitoring the transmitter signal.

In situations where one or more of these criteria cannot be met, Metrix offers other solutions that may be more appropriate, such as vibration transmitters and single-channel monitors that accept an external sensor.

440 Switch

The 440 switch is CSA approved for Class I Div 2 Groups B,C,D hazardous areas. Its enclosure carries a NEMA 4X rating and uses a 3-hole mounting pattern.



440 NEMA 4X ENCLOSURE

450 Switch

The 450 switch has the same internal electronics as the 440, but uses an explosion-proof enclosure for CSA-approved use in Class I Div1 Groups E,F,G, and Class II Div 1 Groups E,F,G, and Class III areas. The standard enclosure (4-hole mounting pattern) is available with a solid cover with NEMA 4. The alternate enclosure (2-hole mounting pattern) is available with NEMA 3, 4, 4X, 7 & 9.



450 (ALTERNATE EXPLOSION PROOF NEMA 3, 4, 4X, 7 & 9 ENCLOSURE)

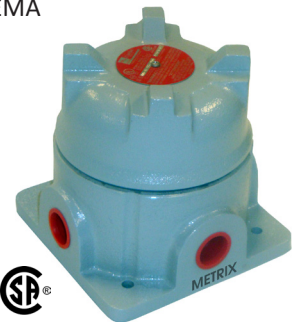

450 (STANDARD EXPLOSION PROOF NEMA 4 ENCLOSURE, SOLID COVER)

Seismic Measurements

440/450 electronic vibration switches are intended for general-purpose seismic vibration measurements on a wide range of rotating and reciprocating machinery with rotative speeds between 120 rpm and 6,000 rpm. Seismic measurements are particularly well-suited for machines that incorporate rolling-element bearings because shaft vibration in such machines is usually transmitted directly through the bearing to the bearing housing, without substantial damping or attenuation. Seismic transducers can also measure vibration that does not originate at the shaft, such as bearing-related wear and defects, footing/foundation problems, piping resonances that are coupled to the machine, etc. Metrix does not recommend seismic measurements as the sole means of protecting machinery with fluid-film bearings where the shaft vibration may not be faithfully transmitted to the measurement location. Thought should be given to the efficacy of such a monitoring strategy before relying substantially or solely upon seismic measurements.

Why Measure Velocity?

When a decision has been made to monitor seismic vibration on the machine casing or support structure, velocity is often the best parameter to use. Acceleration and displacement levels are heavily influenced by the frequency(ies) at which the vibration is occurring, while velocity levels are much less influenced. Thus, although acceleration, velocity, and displacement measurements are inter-related mathematically, seismic velocity measurements tend to be more consistent over a wide range of frequencies than either displacement or acceleration. Consequently, broadband (sometimes called “overall” or “unfiltered”) velocity measurements are appropriate for monitoring many machines as a reliable indicator of damaging vibratory energy, with the notable exception of machines that use fluid-film bearings, which are usually better addressed by shaft-observing proximity probes.

Casing displacement is not a practical measurement to make directly, and is typically just an integrated seismic velocity measurement. As such, the primary decision when selecting a seismic measurement will usually be whether to measure casing velocity or casing acceleration. As noted above, casing velocity will often be more appropriate because it tends to be a more reliable indicator of damaging vibratory energy over a broad frequency spectrum for low- to medium-speed machinery.



NOTE: For machines with fluid-film bearings, shaft-observing proximity probes will provide more effective vibration measurements than seismic transducers due to the rotor dynamics of the machine and the attenuation of vibratory energy through a fluid-film boundary. Accordingly, Metrix recommends and provides proximity probes and associated 4-20 mA transmitters or monitoring systems for such applications.

For machines with rolling element bearings and running speeds above 6,000 rpm, and/or where impulsive casing vibration occurs, acceleration may be a better measurement than velocity. In such situations, it is recommended that you consult with your nearest Metrix sales professional who can review your application and assist with selection of the proper transducer type and associated transmitter or monitoring system.

FEATURES AND BENEFITS

• One or two independently adjustable setpoints

The use of two setpoints* (one for ALERT and one for SHUT-DOWN) is recommended for applications where it is desirable to remotely annunciate an ALERT condition to operators and/or maintenance personnel. This allows appropriate intervention to occur before the machine reaches SHUTDOWN levels. Switches with only a single setpoint are not capable of pre-shutdown warnings unless the 4-20mA output is connected to a PLC or other trending device, and appropriate pre-shutdown alarm limits are programmed in the PLC.

*NOTE: The 440/450 switch provides only over-type (not over/under) alarms.

• LOCKOUT (Power-Up Alarm Inhibit) capabilities

An optional LOCKOUT capability is available for suppressing alarm activation during machine startup conditions when vibration levels may be elevated compared to normal running conditions. When the LOCKOUT option is specified, applying (or cycling) power to the switch suppresses alarms for 20 seconds*, allowing the machine to accelerate through its rough running zone and reach operating speed/load without generating spurious alarms or trips, and without the need to alter setpoints or delays that are suitable for normal running speed of the machine. The 4-20mA output is not affected while the switch is in LOCKOUT mode, allowing actual vibration levels to be displayed and trended at all times.

* NOTE: This delay is set at the factory for 20 seconds and cannot be adjusted in the field. Other delay times may be available upon request as Engineering Specials.

• Accepts Internal or External Sensor

When ordered with the external sensor option, the switch accepts an external accelerometer rather than using an internal accelerometer. The external sensor option is recommended for most applications as it allows the sensor to be mounted at the ideal measurement location and orientation on the machine, without concern for the larger mounting footprint of the vibration switch compared to a sensor. It also allows the vibration switch to be mounted in a more convenient location for viewing and servicing. Also, although the 440/450 is packaged to survive harsh environments of dust, moisture, and corrosion, some machines may exhibit elevated temperatures at the preferred sensor location. Use of an external sensor can allow temperatures as high as 121°C (250°F) at the sensor location and 88°C (190°F) at the vibration switch location.

When an external sensor is not practical, an internal accelerometer can be specified for completely self-contained operation. This allows the switch to be mounted directly at the measurement location and monitor vibration in integrated acceleration (velocity) units. This configuration is suitable when there is sufficient room at the measurement location to mount the switch, when the measurement location still allows the switch to be conveniently viewed and serviced by plant personnel, and when the switch’s inertial mass will not compromise the quality of the vibration measurement.

• RMS amplitude detection

True RMS detection is used to measure the amplitude of the vibration signal. RMS is a good choice for many machines as it is sensitive to the overall vibration energy contained in the waveform without being overly sensitive to short-duration “spikes” that may be contained in the waveform and can lead to spurious alarms or trips on some machines.

- **Easy to wire**

VDE-approved terminal strips accept #12 AWG wire. Terminals use screw-adjustable clamping yoke to provide secure, vibration-proof connections.



- **Simple, intuitive operation**

- Setpoint adjustment knobs are color-coded to easily distinguish between SHUTDOWN (red) and ALARM (yellow) settings. The adjustment scale is graduated in in/sec (rather than percent) to quickly convey switch full scale range.
- LEDs adjacent to each adjustment knob light immediately when a reading is above its setpoint.
- Independent time delay adjustment screws are provided immediately below each setpoint knob. Preset at factory to 3 seconds; adjustable in the field from 2-15 seconds. Time delays ensure that spurious vibration signals do not result in false alarms – measurement must persist above setpoint for duration of time delay to activate alarm circuitry.
- TEST position forces minimum allowable setpoint; any vibration will activate LED immediately; if allowed to persist longer than time delay, the ALARM and SHUTDOWN outputs will activate also, allowing discrete outputs to be tested.

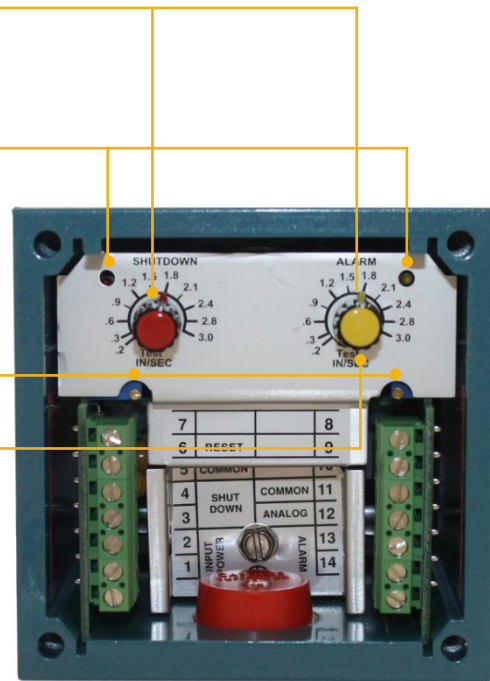

- **Flexible Discrete Output Types**

Discrete outputs are used to externally annunciate alarm conditions and to use the switch as part of an auto-shutdown (i.e., trip) circuit. Switches with one setpoint provide one discrete output. Switches with two setpoints provide two discrete outputs – one for ALARM and one for SHUTDOWN. The outputs can be individually field-configured to have separate time delays and separate shelf states (open on alarm or close on alarm). Any one of three available discrete output formats can be specified at time of ordering:

- **Mechanical Relays**

Mechanical relays are a good choice for most applications as they do not require any holding current to remain in a particular state, have no leakage current, and can be used to switch a large variety of loads. Relays are SPDT and rated for 10A.

- **Triacs**

Triacs are specifically intended for switching heavy AC loads such as electric motors where momentary inrush current can be very high during startup. They are not recommended for most other applications, and are specifically discouraged when the output will connect to light loads such as a PLC or DCS.

- **Solid-State (FET) Relays**

Solid-state relays are designed primarily for applications where the discrete output(s) will be connected to a light load, such as a PLC or DCS. Unlike triacs, solid-state relays require no holding current and have much smaller leakage currents (10 μ A) when in the off state. Because mechanical contacts are not used, arcing, oxidation, use of gold-plated contacts, and other issues associated with mechanical relays and light loads are avoided.

- **Analog 4-20mA output standard**

All switches come with an analog 4-20mA output proportional to vibration velocity where 4mA = 0% of full scale (no vibration) and 20mA = 100% of full scale. This output facilitates easy connection to PLCs, SCADA systems, and other instrumentation for trending and remote display of vibration values. The “live zero” feature allows users to easily distinguish between no vibration (4mA) and no power or loop discontinuity (0mA). The output also provides its own power, eliminating the need for external 24Vdc loop supplies and allowing use of “sinking” type I/O modules at the PLC, DCS, strip chart recorder, or other instrumentation.

- Remote Reset**
 Terminals are provided for remote reset, allowing operators to reset the switch and acknowledge alarms without leaving their station.
- No moving parts, high accuracy/repeatability**
 Unlike mechanical vibration switches, electronic switches have no moving parts and do not rely on internal mechanical tolerances for establishing setpoints or measuring vibration. Setpoints can be established with far better accuracy and repeatability, and much smaller changes in vibration can be detected.
- Velocity Monitoring**
 Unlike mechanical switches which are inherently acceleration sensing devices and require large changes in g-forces to trip, Metrix electronic vibration switches sense vibration velocity – a more suitable measurement for most machines, better able to detect both gross and subtle changes in machinery condition. Velocity is monitored over a wide frequency band from 2Hz to 1000Hz.

SPECIFICATIONS

All specifications are at +25°C (+77°F) unless otherwise noted.

Freq. Range	2 – 1000 Hz (120 – 60000 rpm)
Amplitude Range	See ordering option C (full scale range)
Amplitude Detector Type	True RMS detector; full scale output is scaled to “derived peak” (RMS x $\sqrt{2}$) measurement.
Alarm Time Delay	Field adjustable from 2-15 seconds (factory default setting = 3 sec)
Analog Output	Type: 4-20mA (4mA=0% full scale, 20mA=100% full scale)
	Accuracy: $\pm 10\%$ of setting
	Max Allowable Load Resistance: 450 Ω
Setpoints	Adjustment Location: Internally Accessible
	Accuracy: $\pm 10\%$ of setting
	Repeatability: $\pm 2\%$ of setting
	Range / Engineering Units <ul style="list-style-type: none"> 1.5 in/s models: 0.1 to 1.5 in/s 3.0 in/s models: 0.2 to 3.0 in/s 40 mm/s models: 3 to 40 mm/s 80 mm/s models: 6 to 80 mm/s
Power-up Timed Inhibit (i.e., Lock-out)	Number: <ul style="list-style-type: none"> DR models: 2 (alarm & shutdown) SR models: one (shutdown only)
	Optional (see ordering option H); factory set at 20 seconds (non-adjustable); invoked at initial power up or by interrupting power to the switch

Auto Reset	Configurable; switch can be configured with latching alarms requiring manual reset or non-latching alarms that automatically reset when vibration falls back below setpoint(s)	
Remote Reset	Available via wiring terminals; short terminals to reset/acknowledge alarms.	
Local Reset	Model 440: Optional via local pushbutton on switch housing (see ordering option F); remote reset not available when local reset specified. Local reset not compatible with hazardous area approvals. Model 450: Local reset pushbutton not available.	
Contact Ratings	Triacs	
	Continuous Current	5A
	Surge & Overload (Duty cycle < 1%)	25 A for 1 sec
		50 A for 16 ms
		100A for 10ms
		125 A for 1 ms
	Max. Voltage	140 VAC (115 V model)
		280 VAC (230V model)
	Max. off state leakage current	1 mA
	Isolation	2500 VAC
	Minimum required holding current	50 mA (typical)
	Solid-State Analog Switches (FETs)	
	Continuous Current	170 mA
	Max. Voltage	250V
	Max. off state leakage current	10 μ A
	Isolation	2500V
	Required holding current	None
Electromechanical Relays		
Rating	10A @ 125VAC 6A @ 277VAC 5A @ 30VDC 1/8HP @ 125VAC 1/8HP @ 277VAC	
Maximum Switching Current	10A (AC) 5A (DC)	
Minimum Switching Capacity	100mA, 5VDC	
Type	Form C (SPDT)	
Contact Material	Silver (AgSnO ₂ type)	

Input Power	Options for: <ul style="list-style-type: none"> • 100-130 VAC, 50/60 Hz • 200-260 VAC, 50/60 Hz • 24 VDC ±10% Refer to ordering option G
Power Consumption	≤ 4 W
Light Emitting Diodes (LEDs)	One LED for each setpoint, illuminates immediately upon setpoint violation (i.e., not affected by alarm delay)
Buffered transducer output	Model 440: Standard option for BNC connector (see ordering option F); local BNC connector not compatible with hazardous area approvals; buffered output is unfiltered 100 mV/g acceleration signal (not velocity signal). Model 450: Not available as standard; a special modification is available that provides a BNC connector inside* the housing; consult the factory. * NOTE: Requires removal of enclosure lid for access.
Vibration Sensitive Axis	Perpendicular to mounting base; unit can be mounted in any orientation without change in sensitivity of this axis.
Self Test	One for each setpoint; allows functional testing of setpoint circuitry, time delay, and discrete output operation; permits online verification
Wiring Entries	Model 440: One (3/4" NPT) Model 450: Two (3/4" NPT)
Wiring Terminals	Accept up to 12 AWG wire; use yoke-type clamps; all wiring terminal blocks are captive (non-removable)
Enclosure Rating	NEMA 4X
Enclosure Material	Model 440: Copper-free aluminum; light zinc chromate coating for corrosion resistance; epoxy powder finish inside and out; color: metallic blue Model 450: Copper-free aluminum; electrostatically applied powder epoxy/polyester finish (exterior only); color: gray
Humidity	1% to 100% (non-condensing)
Temperature Limits	Units with internal accelerometer: -30°C to +60°C (-20°F to +140°F) Units with external sensor: -55°C to +88°C (-65°F to +190°F)

Elevation Limit	2,000 m (6562 ft) above sea level Max. operating temperature must be derated 2% for every 305m above 2000m NOTE: Atmospheric pressure at elevations ≥ 2000m reduces heat dissipation and must be accounted for when determining max. operating temperature.
Mounting	Model 440: 3-hole triangular pattern via mounting bosses; uses ¼" hardware; see Figure 1 Model 450 w/ solid cover (F=0): 4-hole square pattern; uses ¼" hardware; see Figure 2. Model 450 w/ lens cover (F=9): 2-hole square pattern; uses ¼" hardware; see Figure 3.
Agency Certifications	Model 440: CSA Class I Div 2 Grps B,C,D, NEMA 4X Model 450: CSA Class I Div 1 Grps B,C,D Class II Div 1 Grps E,F,G Class III NEMA 3, 4, 4X, 7 & 9
Weight	Model 440: 1.6 kg (3.5 lbs) Model 450: 2.7 kg (6.0 lbs)

ORDERING INFORMATION



440-A-BCDE-FGHI ¹ 440 Electronic Vibration Switch		
A		Number of Alarm Setpoints³
	SR	One alarm setpoint ²
	DR	Two alarm setpoints
B		Analog Proportional Output
	2	4-20 mA(absolute) ⁴
C		Scale Range^{4,5}
	0	0.1 – 1.5 in/sec (derived peak)
	1	0.2 – 3.0 in/sec (derived peak)
	2	3 – 40 mm/sec (derived peak)
	3	6 – 80 mm/sec (derived peak)
D		Shutdown Circuit Output⁶
	0	Triac (5A, SPST) ⁷
	2	Solid-state switch (170 mA, 250 Vpk) ⁸
	4	Electromechanical relay (10A, SPDT)
E		Alarm Circuit Output⁶
	0	None ²
	1	Triac (5A, SPST) ⁷
	2	Solid-state switch (170 mA, 250 Vpk) ⁸
	4	Electromechanical relay (10A, SPDT)
F		Approvals / Local Reset / BNC connector
	0	CSA Approvals (Class I, Div 2, Gps B-D) No local reset pushbutton No BNC connector
	2	No Approvals ⁹ Local reset pushbutton ¹⁰ No BNC connector
	7	No Approvals ⁹ No local reset pushbutton Local BNC with 100 mV/g accel signal ¹¹
	8	No Approvals ⁹ Local reset pushbutton Local BNC with 100 mV/g accel signal ¹¹
G		Input Power
	0	115 Vac, 50/60 Hz
	1	230 Vac, 50/60 Hz
	2	24 Vdc
H		Power-up Timed Inhibit (i.e., LOCKOUT)¹²
	0	None
	2	20-sec delay ¹³
I		Transducer Option
	0	Internal Accelerometer
	5	External Accelerometer

NOTES:

- Various other configurable options were available on older Metrix or PMC/BETA 440 switches and may use other digits and/or longer part numbers than those shown here. Consult the factory when ordering spares for (or replacing) such switches.
- When a single alarm setpoint is ordered (A = SR), only a shutdown circuit is provided and option E must be 0.
- Some older switches may simply be labeled “S” instead of “SR” and “D” instead of “DR”.
- The analog proportional output (option B) is related to scale range (option C) and will be 4mA when vibration levels are at or below the bottom scale range. 4 mA = bottom scale range and 20 mA = top scale range.
- The 440 switch uses a true RMS amplitude detector and scales its output by 1.414 (RMS x $\sqrt{2}$) to give a so-called “derived peak” measurement. Because this measurement is derived from the RMS value, it will equal true peak only under the special case of a pure sinusoid, not complex vibration signals.
- For dual setpoint switches, the type of output for shutdown and alarm circuits must be the same. For example, a 440-DR switch with a Triac shutdown circuit (D=0) must also use a Triac alarm circuit (E=1).
- Triac output types are recommended when switching medium power rated AC devices such as motor starters, contactors, and relays. However, triacs require a 50mA holding current and exhibit a leakage current of 1mA.
- Solid-state switch output types are recommended for connection to light loads such as discrete inputs on PLCs or DCSs. This output type is easier to interface as it has virtually no leakage current (10 μ A or less), and does not require any holding current. It also switches AC or DC signals equally well.
- Approvals are not available when a local reset pushbutton and/or BNC connector and/or external accelerometer is specified.
- When a local reset pushbutton is supplied, the remote reset terminals are not available for wiring.
- Although the switch monitors in RMS velocity units, the signal at the optional BNC connector is unfiltered 100mV/g acceleration directly from the sensing element.
- The optional Power-up Timed Inhibit (LOCKOUT) feature is invoked by initial application of (or cycling) primary power to the switch. This feature inhibits alarms from activating for 20 seconds. This feature is used primarily as a “startup delay” capability for machines that exhibit elevated vibration levels during startup relative to normal running levels. To invoke the feature in this manner, power to the switch should be applied (or cycled) concurrent with machine startup.
- 20-sec delay is factory set and not adjustable. Power-up Inhibit state is not annunciated externally and the switch will automatically resume normal alarming functions after 20 seconds have elapsed.

ORDERING INFORMATION

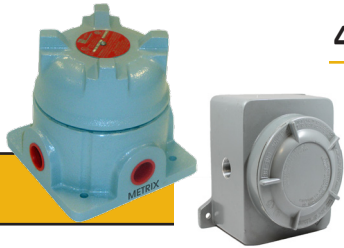

450-A-BCDE-FGHI ¹		450 Electronic Vibration Switch	
A		Number of Alarm Setpoints³	
	SR	One alarm setpoint ²	
	DR	Two alarm setpoints	
B		Analog Proportional Output	
	2	4-20 mA(absolute) ⁴	
C		Scale Range^{4,5}	
	0	0.1 – 1.5 in/sec (derived peak) ⁵	
	1	0.2 – 3.0 in/sec (derived peak) ⁵	
	2	3 – 40 mm/sec (derived peak) ⁵	
	3	6 – 80 mm/sec (derived peak) ⁵	
D		Shutdown Circuit Output⁶	
	0	Triac (5A, SPST) ⁷	
	2	Solid-state switch (170 mA, 250 Vpk) ⁸	
	4	Electromechanical relay (10A, SPDT)	
E		Alarm Circuit Output⁶	
	0	None ²	
	1	Triac (5A, SPST) ⁷	
	2	Solid-state switch (170 mA, 250 Vpk) ⁸	
	4	Electromechanical relay (10A, SPDT)	
F		Housing / Approvals	
	0	Standard NEMA 4 housing (4-hole pattern) Solid cover CSA Class I Div 1 Groups B-D approvals CSA Class II Div 1 Groups E-G CSA Class III	
	9	Alternate NEMA 3, 4, 4X, 7 & 9 housing (2-hole pattern) CSA Class I Div 1 Groups B-D approvals CSA Class II Div 1 Groups E-G CSA Class III	
G		Input Power	
	0	115 Vac, 50/60 Hz	
	1	230 Vac, 50/60 Hz	
	2	24 Vdc	
H		Power-up Timed Inhibit (i.e., LOCKOUT)⁹	
	0	None	
	2	20-sec delay ¹⁰	
I		Transducer Option	
	0	Internal Accelerometer	
	5	External accelerometer ¹¹	

NOTES:

1. Various other configurable options were available on older Metrix or PMC/BETA 450 switches and may use other digits and/or longer part numbers than those shown here. Consult the factory when ordering spares for (or replacing) such switches.
2. When a single alarm setpoint is ordered (A = SR), only a shutdown circuit is provided and option E must be 0.
3. Some older switches may simply be labeled “S” instead of “SR” and “D” instead of “DR”.
4. The analog proportional output (option B) is related to scale range (option C) and will be 4mA when vibration levels are at or below the bottom scale range. 4 mA = bottom scale range and 20 mA = top scale range.
5. The 450 switch uses a true RMS amplitude detector and scales its output by 1.414 (RMS x $\sqrt{2}$) to give a so-called “derived peak” measurement. Because this measurement is derived from the RMS value, it will equal true peak only under the special case of a pure sinusoid, not complex vibration signals.
6. For dual setpoint switches, the type of output for shutdown and alarm circuits must be the same. For example, a 450-DR switch with a Triac shutdown circuit (D=0) must also use a Triac alarm circuit (E=1).
7. Triac output types are recommended when switching medium power rated AC devices such as motor starters, contactors, and relays. However, triacs require a 50mA holding current and exhibit a leakage current of 1mA.
8. Solid-state switch output types are recommended for connection to light loads such as discrete inputs on PLCs or DCSs. This output type is easier to interface as it has virtually no leakage current (10 μ A or less), and does not require a 50mA holding current. It also switches AC or DC signals equally well.
9. The optional Power-up Timed Inhibit feature is invoked by initial application of (or cycling) primary power to the switch. This feature inhibits alarms from activating for 20 seconds. This feature is used primarily as a “startup delay” capability for machines that exhibit elevated vibration levels during startup relative to normal running levels. To invoke the feature in this manner, power to the switch should be applied (or cycled) concurrent with machine startup.
10. 20 sec delay is factory set and not adjustable. Power-up Inhibit state is not annunciated externally and the switch will automatically resume normal alarming functions after 20 seconds have elapsed.
11. Use Explosion-Proof transducer housing model 7295-002. The housing is CSA approved for Class I Groups A-D and Class II Groups E-G.

WIRING DIAGRAMS

Refer to Metrix Product Manual #90018-031

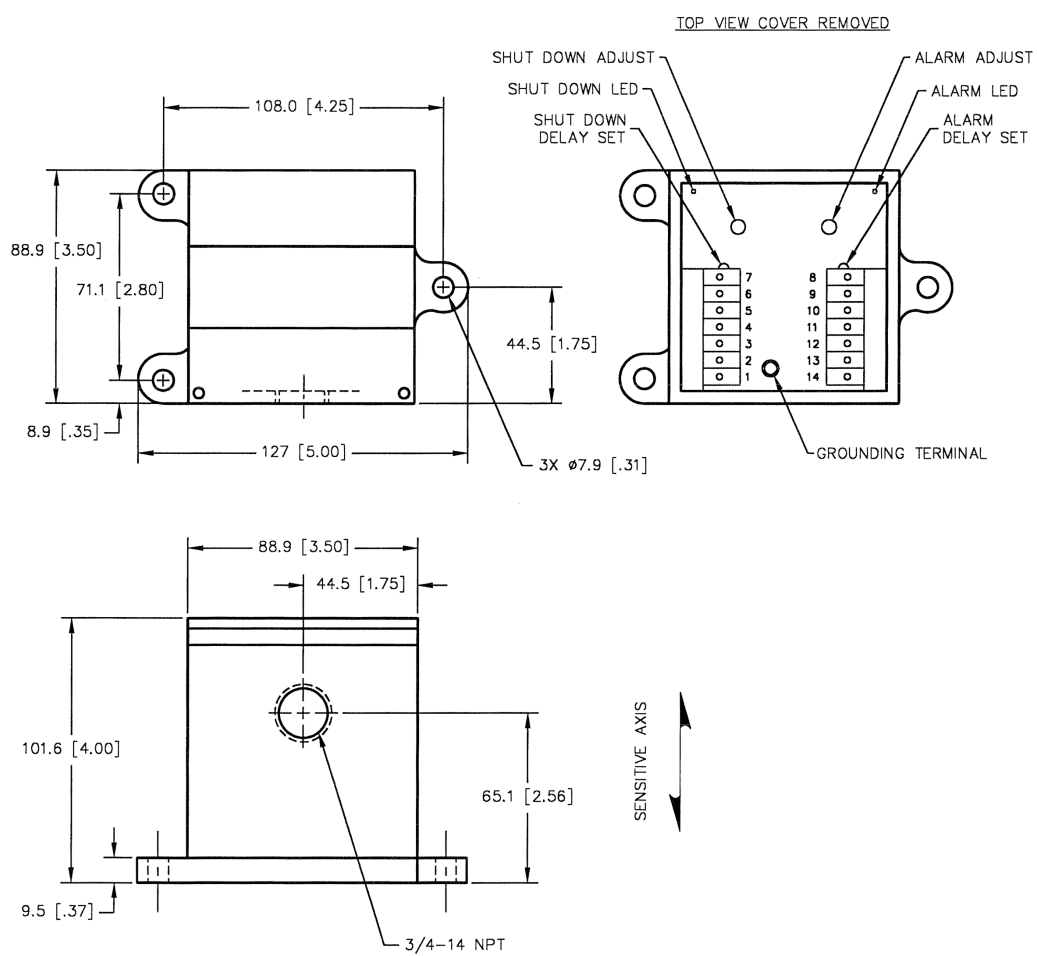

**FIGURE 1 – MODEL 440 ELECTRONIC VIBRATION SWITCH
(TOP COVER REMOVED DEPICTS DR MODEL)**

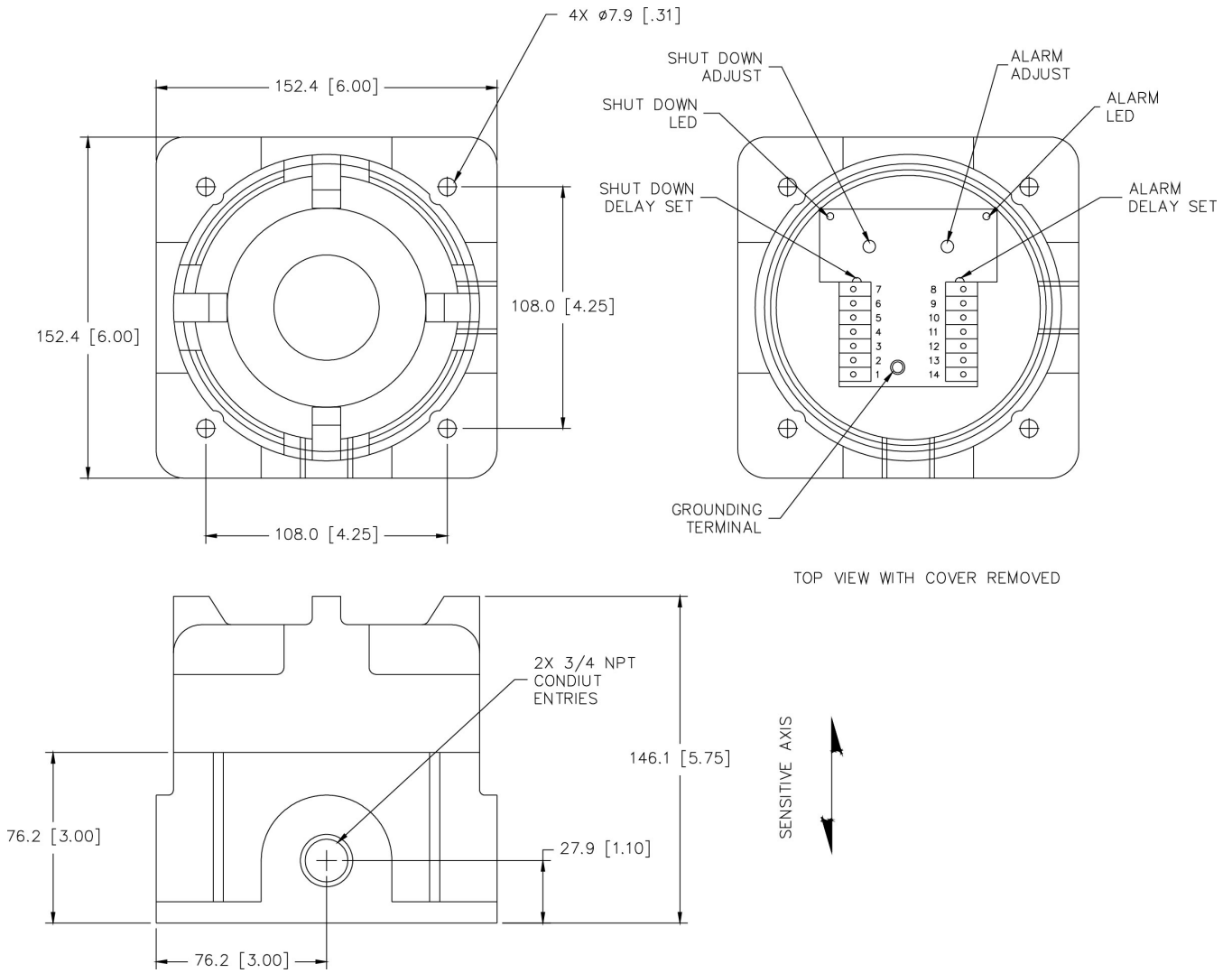

**FIGURE 2 – MODEL 450 ELECTRONIC VIBRATION SWITCH WITH SOLID DOME COVER (OPTION F=0)
(TOP COVER REMOVED DEPICTS DR MODEL)**

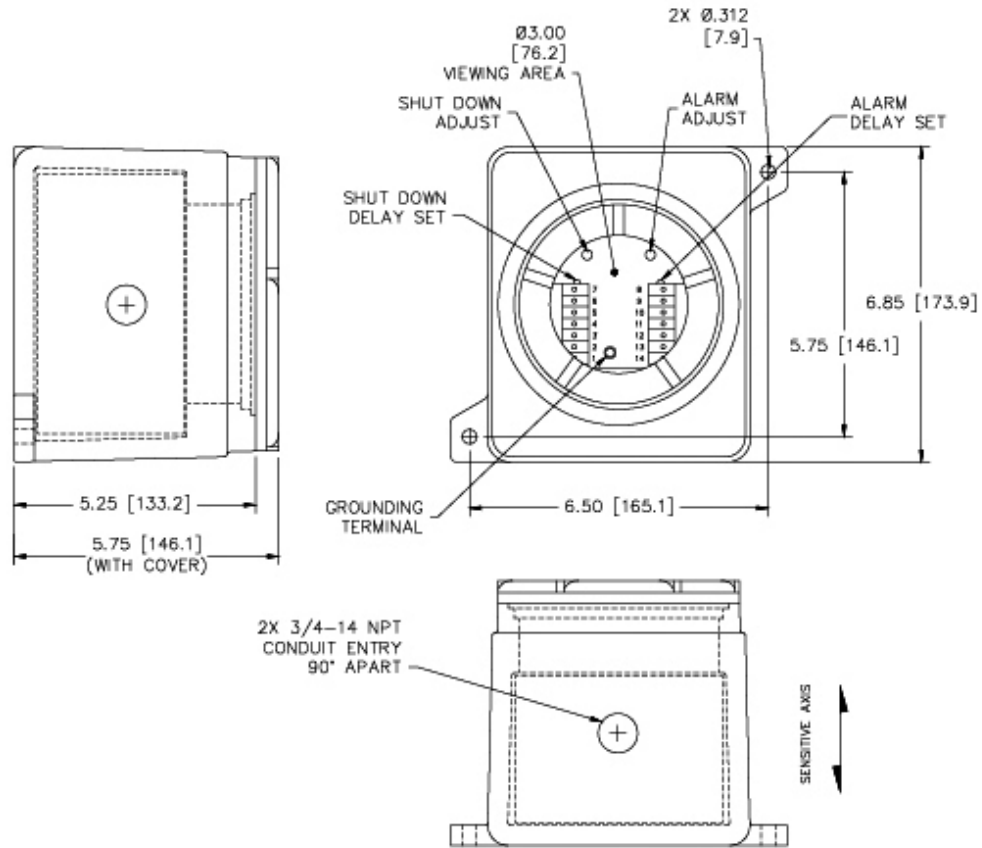

FIGURE 3 – MODEL 450 ELECTRONIC VIBRATION SWITCH WITH ALTERNATE HOUSING STYLE (OPTION F=9) (SWITCH INTERNALS DEPICT DR MODEL)