

Gear Pump Units

For single-line centralized lubrication systems



These units comprising the MFE Group are designed to supply the lubricant used in intermittently operated, single-line centralized lubrication systems.



Pump overview

Order No. ¹⁾	Medium		Flow rate [l/min]	Reservoir capacity [litres]	Reservoir material		Design features / Special technical features	Page
	Oil	Fluid grease			Plastic	Metall		
MFE2-KW3F-2	•		0.2	3	•		24 V mit lubricant level switch with M12x1 plug connector	4
MFE2-KW3F-S9+MGP	•		0.2	3	•		24 V level monitoring with M12x1 plug connector Motor with Harting connector	4
MFE2-K3F	•		0.2	3	•			4
MFE2-KW6F-S1	•		0.2	6	•		Two 24 V lubricant level switches for minimum and advance warning	4
MFE2-KW6F-S5	•		0.2	6	•		Two 24 V lubricant level switches for minimum and advance warning	4
MFE2-KW6F-S6	•		0.2	6	•		Two 24 V lubricant level switches for minimum and advance warning	4
MFE2-KW6F-S7	•		0.2	6	•		Two 24 V lubricant level switches for min. and max. level	4
MFE2-KW6F-S13	•		0.2	6	•		Two 24 V lubricant level switches for minimum and advance warning Motor UL (appr.)	4
MFE2-KW6F-S16	•		0.2	6	•		Two 24 V lubricant level switches for minimum and advance warning with M12x1 plug connector; Filler coupling	4
MFE2-KW6F-S21	•		0.2	6	•		Two 24 V lubricant level switches for minimum and advance warning with M12x1 plug connector Motor with Harting connector	4
MFE2-BW7F-S3	•		0.2	6		•	Two 24 V lubricant level switches for minimum and advance warning	4
MFE5-KW3-2	•		0.5	3	•		Basic version with WS32-2 float switch	10
MFE5-KW3-2-S4	•		0.5	3	•		Basic version with WS35-2 float switch	10
MFE5-KW3-2-S9	•		0.5	3	•		For oil as 5 mm ² /s at max. 16 bars	10
MFE5-KW3-2-S13	•		0.5	3	•		Unit for 50/95 weatherproofing (DIN 50015); WS32-2 float switch	10
MFE5-KW3-S24	•		0.5	3	•		Motor with HAN6ES Harting connector; WS35-S30 float switch	10
MFE5-BW3-2	•		0.5	3		•	Basic version with WS32-2 float switch	9
MFE5-BW3-2-S14	•		0.5	3		•	WS35-2 float switch; Stäubli filler coupling	9
MFE5-BW3-2-S22	•		0.5	3		•	For oil as 5 mm ² /s at max. 16 bars	9
MFE5-BW3-2-S34	•		0.5	3		•	Motor UL/CSA	9
MFE5-BW3-2-S37	•		0.5	3		•	Basic version with WS35-2 float switch	9
MFE5-BW3-S41	•		0.5	3		•	Motor with HAN6ES Harting connector; WS35-S30 float switch	9
MFE5-KW6	•		0.5	6	•		Basic version with WS32-2 float switch	10
MFE5-KW6-S1	•		0.5	6	•		Basic version with WS35-2 float switch	10
MFE5-KW6-S8	•		0.5	6	•		FKM (FPM) version, WS32-S8 float switch	10
MFE5-KW6-S33	•		0.5	6	•		Motor with HAN6ES Harting connector; WS35-S30 float switch	10
MFE5-BW7	•		0.5	6		•	Basic version with WS32-2 float switch	9
MFE5-BW7-CF	•		0.5	6		•	Basic version with WS35-2 float switch	9
MFE5-BW7-S8	•		0.5	6		•	FKM (FPM) version, WS32-S8 float switch	9
MFE5-BW7-S22	•		0.5	6		•	Motor UL/CSA	9
MFE5-BW7-S29	•		0.5	6		•	WS35-2 float switch; Stäubli filler coupling	9
MFE5-BW7-S54	•		0.5	6		•	Unit for 50/95 weatherproofing (DIN 50015); WS32-2 float switch	9
MFE5-BW7-S107	•		0.5	6		•	Motor with HAN6ES Harting connector; WS35-S30 float switch	9
MFE5-BW15	•		0.5	15		•	Basic version with WS32-2 float switch; reservoir	11
MFE5-BW16	•		0.5	15		•	Basic version with WS35-2 float switch; foot-mounted reservoir	11
MFE5-BW15-S7	•		0.5	15		•	Grundausführung mit Schwimmerschalter WS35-2; reservoir	11
MFE5-BW16-S93	•		0.5	15		•	Motor mit Hartingstecker HAN6ES; Schwimmerschalter WS35-S30	11

1) When ordering, the order no. should be supplemented with the power key.

Pump overview

CAUTION

The important information on product usage located on the back cover applies to all systems described in this brochure.



Gear pump units MFE2

Reservoir material	Plastic
Lubricant	Metal
Page	Fluid grease
	4/5

Fill level monitoring	optional
Reservoir capacity	3 or 6 litres
Flow rate	0.2 l/min



Gear pump units MFE5

Reservoir material	Plastic
Lubricant	Oil
Page	10

Fill level monitoring	optional
Reservoir capacity	3, 6 or 15 litres
Flow rate	0.5 l/min



Gear pump units MFE5

Reservoir material	Metal
Lubricant	Oil
Page	9/11

Fill level monitoring	optional
Reservoir capacity	3, 6 or 15 litres
Flow rate	0.5 l/min

MFE2 gear pump unit for fluid grease with main line automatic pressure relief

These units are designed for centralized lubrication systems used in conjunction with piston distributors (total-loss lubrication) and are equipped with the required relief and safety valves.

The drive is provided by a three-phase motor.

The pumps are located below the grease level, in contrast to oil units.

Intermittent operation is required for the distributors' sequence of operation: when the pump is running, the distributors are pressurized, when the pump is at rest,

the main line is relieved of pressure and the distributors reverse. This work cycle is achieved by timing the electric motor.

For suitable control units, see brochures 1-1700-1-EN – 1-1700-4-EN

Overview order No.

Order No. ¹⁾	Reservoir capacity [litres]	Reservoir capacity		Special technical feature
		Plastic	Metal	
MFE2-KW3F-2	3	•		24 V mit lubricant level switch with M12×1 plug connector
MFE2-KW3F-S9+MGP	3	•		24 V level monitoring with M12×1 plug connector Motor with Harting connector
MFE2-K3F	3	•		
MFE2-KW6F-S1	6	•		Two 24 V lubricant level switches for minimum and advance warning
MFE2-KW6F-S5	6	•		Two 24 V lubricant level switches for minimum and advance warning
MFE2-KW6F-S6	6	•		Two 24 V lubricant level switches for minimum and advance warning
MFE2-KW6F-S7	6	•		Two 24 V lubricant level switches for min. and max. level
MFE2-KW6F-S13	6	•		Two 24 V lubricant level switches for minimum and advance warning Motor UL (appr.)
MFE2-KW6F-S16	6	•		Two 24 V lubricant level switches for minimum and advance warning with M12×1 plug connector
MFE2-KW6F-S21	6	•		Two 24 V lubricant level switches for minimum and advance warning with M12×1 plug connector Motor with Harting connector
MFE2-BW7F-S3	6		•	Two 24 V lubricant level switches for minimum and advance warning

1) When ordering, the order no. should be supplemented with the power key.

MFE2 gear pump unit for fluid grease with main line automatic pressure relief

Technical data

Unit

Flow rate	0,2 l/min
Continuous operation at p max.	20 bar
Brief operation at p max.	38 bar
Operation temperature	-10 to +40 °C
Mounting position	as shown
Lubricant	Fluid grease, NLGI grades 000, 00 compatible with plastics, NBR elastomers, copper and copper alloys

Motor

Rated power	70 W
Speed ¹⁾	2 700 min ⁻¹
Type of enclosure to DIN 40050	IP54
Insulation class	F
Voltage	cf. table 1
Frequenza	50/60 Hz

Level switch

MFE2-KW3F-2	24 V DC/250 mA
MFE2-KW6F-S1	10 to 55 V DC

Connectable load:

brief operation (max. 1s)	max. 1 A
continuous operation	max. 350 mA

(andere Aggregate auf Anfrage)

1) With frequency 50 Hz

Voltage (please indicate range when ordering)

Range I Δ/Y 100–130 V / 173–225 V, 50 Hz Δ/Y 0.90/0.53 A
Δ/Y 120–156 V / 208–270 V, 60 Hz

Range II Δ/Y 207–254 V / 360–440 V, 50 Hz Δ/Y 0.50/0.29 A
Δ/Y 249–305 V / 432–528 V, 60 Hz

Range III Δ/Y 230–290 V / 398–500 V, 50 Hz Δ/Y 0.40/0.23 A
Δ/Y 290–346 V / 500–600 V, 60 Hz

Any voltages deviating from these ranges can only be used for the respectively ordered voltage and frequency.

Fig. 1

MFE2-KW3F-2

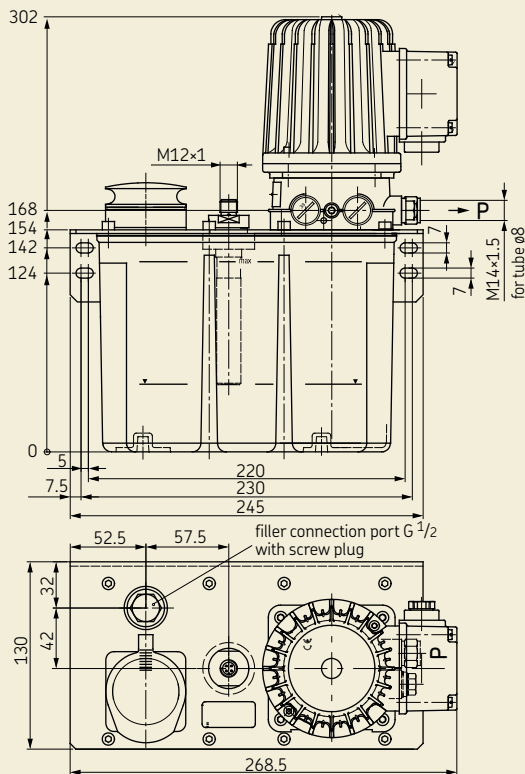
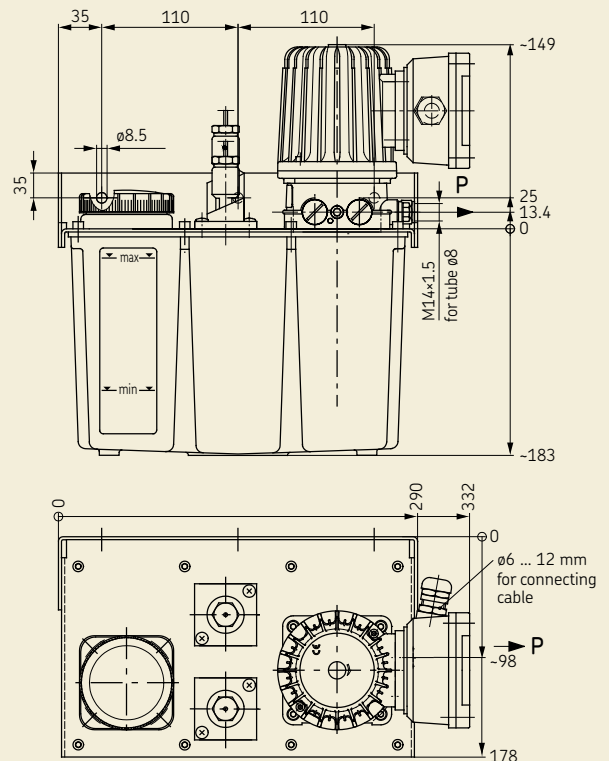

Fig 2

MFE2-KW6F-S1



MFE5 gear pump unit for oil

Gear pump unit mounted separate from oil reservoir

Order No. **ME5**

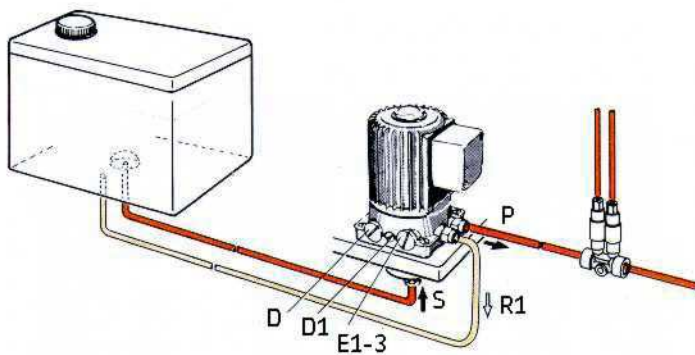

fig. 1

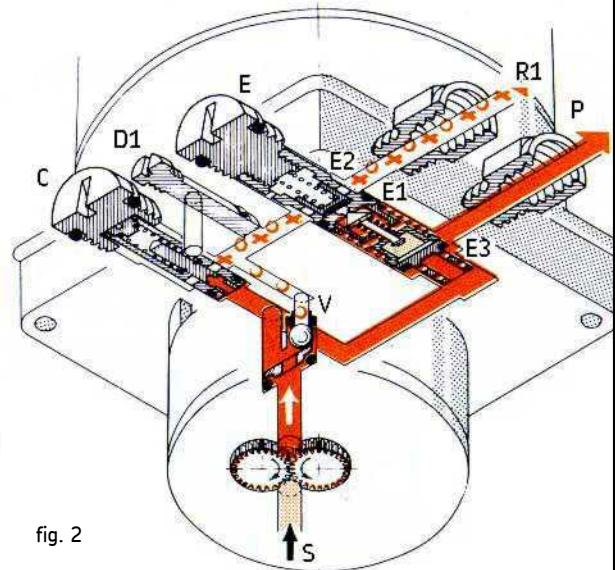

fig. 2

Gear pump unit for flange-mounting on oil reservoir

Order No. **MFE5**

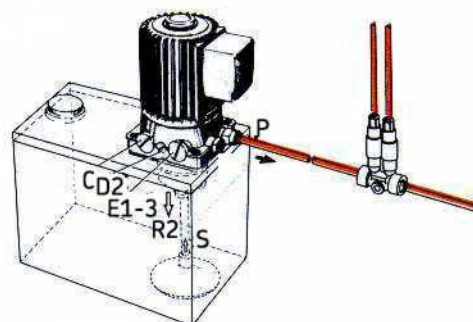

fig. 3

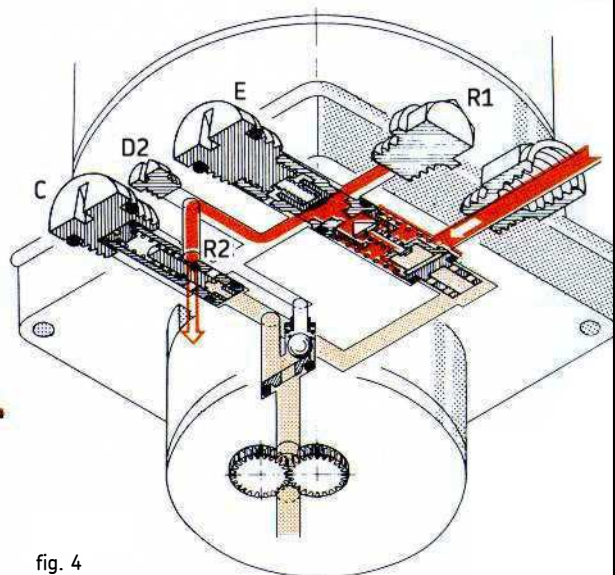

fig. 4

Please provide voltage and frequency when ordering.

A special sealed pump must be used for horizontal flange-mounting of the unit in a position below the oil level.

For gear pump unit model MFE5 complete with metal or plastic reservoir (3, 6 and 15 liters) see the pages 9 – 11.

1-1202-EN

MFE5 gear pump unit for oil

Explanation of hydraulic function

Both (ME5, MFE5) types have the same hydraulic function.

Oil is sucked in at S and flows under pressure through the duct in the direction P. The oil pressure closes valve V and opens valve E3, at the same time closing valve E1 against spring tension. If air is entrained (due to low oil level in the reservoir), valve V remains open and diverts the air or, respectively, the air-oil mixture into the return duct (see bubble (o) marking in direction R1). Valve C allows oil under overpressure to flow out into the return duct (see cross (+) marking).

When the unit stops (interval time), spring-loaded valve E1 opens and valve E3 simultaneously closes. The system pressure at P can now be released through valve E1 – with the exception of a small amount of residual pressure determined by valve E2. This pressure release is required for the piston distributors to function correctly. The pressure relief process is shown in fig. 4.

Explanation of the structural differences

In the case of model ME5, the long screw plug D1 blocks flanged port R2 of the return duct. The oil returning from valves V, C and E1 flows via port R1 through a tube to the separately mounted oil reservoir (see fig. 1 and 2).

In the case of model MFE5, the short screw plug D2 – unlike D1 with model ME5 – leaves flanged port R2 open. A plug closes off external port R1. Flanged port R2 of the return duct drains directly into the reservoir without any connection threads (see fig. 3 and 4).

Fig. 3

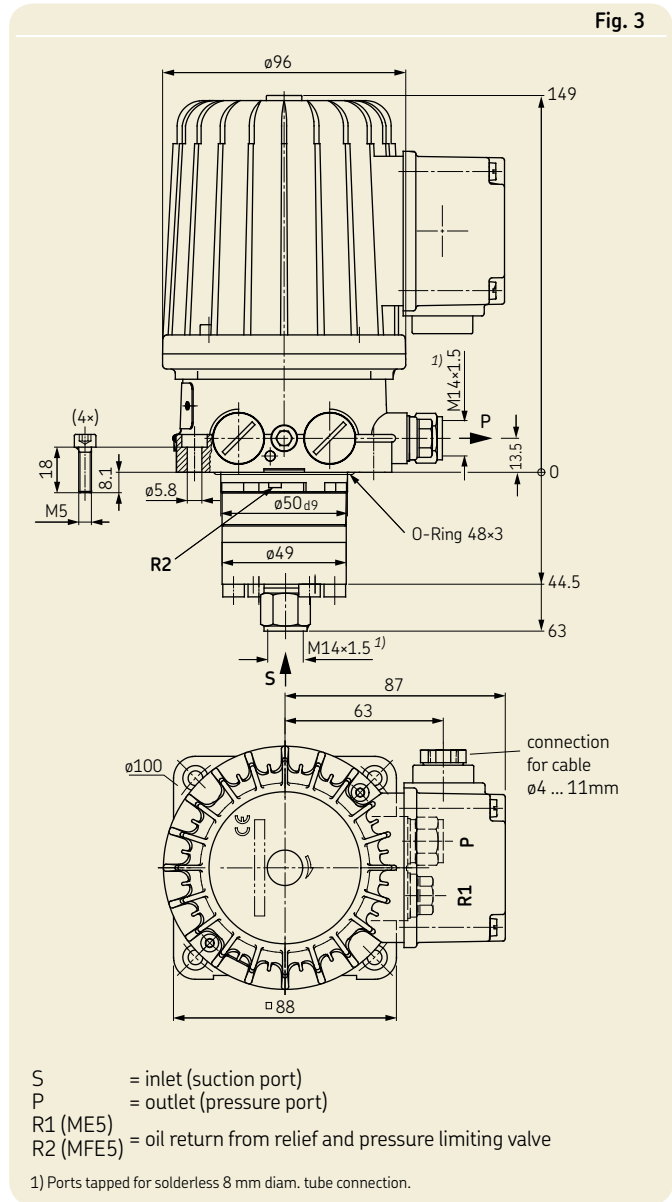

S = inlet (suction port)
 P = outlet (pressure port)
 R1 (ME5) = oil return from relief and pressure limiting valve
 R2 (MFE5)

1) Ports tapped for solderless 8 mm diam. tube connection.

MFE5 unit variants *

Order No. ¹⁾	Flow rate [l/min]	Max. back pressure [bar]	Design
MFE5-2000	0.5	28	Basic version, NBR, plastic terminal box
MFE5-3041	0.5	28	Basic version, NBR, metal terminal box
MFE5-2000-D	0.5	28	Installed below oil level, NBR, plastic terminal box
MFE5-3000-D	0.5	28	Installed below oil level, NBR, metal terminal box.
MFE5-2008	0.5	28	Basic version, FKM (FPM), plastic terminal box
MFE5-2009	0.25	17,5	For light oil as 5 mm ² /s, NBR
MFE5-2053	0.25	17,5	For light oil as 5 mm ² /s, FKM
MFE5-4000	0.5	28	UL/CSA-approved, NBR
MFE5-5000	0.5	28	CCC-approved, NBR
MFE5-1001	0.5	28	HAN6ES Harting connector, NBR, motor 180° turned
MFE5-1088	0.5	28	HAN10ES Harting connector, FKM
MFE5-S67	0.5	28	50/95 weatherproof, NBR, metal terminal box

*) The geometrical dimensions of the variants can deviate of the one shown in Fig.3.
 1) When ordering, the order no. should be supplemented with the power key.
 2) Flow rate based on an operating viscosity of 140 mm²/s, at a back pressure of p = 5 bars.
 3) The max. back pressure is equivalent to the actual value of the built-in pressure limiting valve. If the units are operated with a single-phase AC supply, only 60% of the indicated pressure is permissible, i.e. a 16-bar pressure limiting valve should be fitted to the system.
 The appropriate capacitors for a frequency of 50 and 60 Hz are:
 230 V ... 8 μ F; order No. 179-340-007
 115 V ... 30 μ F; order No. 179-340-060

Technical data of the shown motor

Motor	Three-phase motor
Mode of operation	S1, 100%
Insulation class	F
Rated frequency	50/60 Hz
Voltage ⁴⁾	400/480 V
Rated current	0.29 A
Rated power	0.075/0.09 kW
Rated speed	2700/3200 min ⁻¹
Rated flow rate	0,5/0,6 l/min
Operating pressure	28 bar
Operating temperature	+10 to 40 °C
Medium	20 to 1000 mm ² /s
Type of enclosure acc. to DIN 50050	IP 54
Max. suction head	500 mm

4) See page 8: „Multivoltage motors“

Multi-voltage motors for pump units (assembly M..)

Many export oriented companies have to deal with voltages/frequencies that deviate from those in Germany. To make it easier for them to buy the most common pump units for centralized lubrication systems, we have developed 3 multirange motors that cover a wide range of three-phase voltages and frequencies.

Pump units with or without oil reservoirs are included, provided the hydraulic power data listed in the brochures are not exceeded (limit values).

These pump units are designated as:

M2, MF2, MFE2, M5, MF5, MFE5, FLM12-3, FLMF12-3, M202

Limit values for

0.2 l-units (M..2-Group): 27 bars – 2 000 mm²/s eff.

0.5 l-units (M..5-Group): 27 bars – 1 000 mm²/s eff.

1.2 l-units FLM12-3: 6 bars – 850 mm²/s eff.

2×0.2 l-units M202: 12 bars – 850 mm²/s eff.

Our experience shows these units can meet almost every need.

That means simplified warehousing for our customers and shorter delivery times, since we always have these 3 types of motors in stock.

Range I

100-130 V / 173-225 V, 50 Hz
120-156 V / 208-270 V, 60 Hz

Order code: 199

Order code ISO-F: 19E

Range II

207-254 V / 360-440 V, 50 Hz
249-305 V / 432-528 V, 60 Hz

Order code: 299

Order code ISO-F: 29E

Range III

230-290 V / 398-500 V, 50 Hz
290-346 V / 500-600 V, 60 Hz

Order code: 399

Order code ISO-F: 39E

A tailor-made motor has to be used instead of a multirange motor in the following cases:

- when the desired operating voltage cannot be covered by one of the three voltage ranges,
- when the operating voltage, with the voltage tolerances to be expected, exceeds a defined voltage benchmark for the range,
- in the case of motors with PTC thermistor sensors,
- for dual-circuit pump unit, e.g. M205
- in the case of motors with UL/CSA version
- for units with a 4-pole motor

Table 1

Voltage	Order code
230/400 V, 50 Hz	140
230/400 V, 60 Hz	640
240/415 V, 50 Hz	150
240/415 V, 60 Hz	650
255/440 V, 50 Hz	165
255/440 V, 60 Hz	665
265/460 V, 50 Hz	175
265/460 V, 60 Hz	675
265/460 V, 60 Hz, UL	563
265/460 V, 60 Hz, CSA	676
280/480 V, 60 Hz	680
280/480 V, 60 Hz, UL	562
280/480 V, 60 Hz, CSA	681
280/480 V, 60 Hz, UL/CSA	564

MFE5 gear pump unit with 3 or 6 liter meatl reservoir

Overview order No.

Order No. ⁴⁾	Flow rate [l/min]	Reservoir capacity [litres]	Reservoir material	Order No. without float switch
MFE5-BW3-2	0,5	3	die-cast aluminum	MFE5-B3-2
MFE5-BW7	0,5	6	sheet steel	MFE5-B7

4) When ordering, the order no. should be supplemented with the power key.

Technical data

Float switch (WS) for monitoring of minimum oil level

Type of contact	1 changeover
Max. switching voltage	230 V AC / 230 V DC
Max. switching current	1.0 A
Max. switching capacity	60 VA / 40 W ⁵⁾
Type of enclosure	IP 65
Temperature range	-10 to +60 °C

5) Take appropriate measures to protect contacts when switching inductive loads.

See page 5 for further information.

Fig. 4

Hydraulic layout MFE5-BW3-2

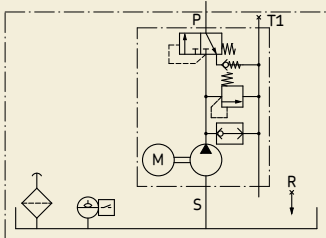
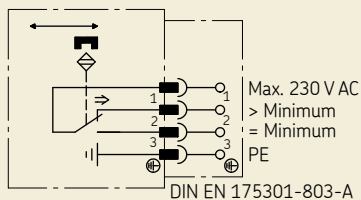

Fig. 5

Circuit diagram for float switch (WS)



Function – float switch (WS)

When the oil drops to a minimum level, contact 1–2 opens and contact 1–3 closes.

With plug-type connector that complies with DIN EN 175301-803-A
Depicted: full reservoir

Fig. 6

MFE5-BW3-2

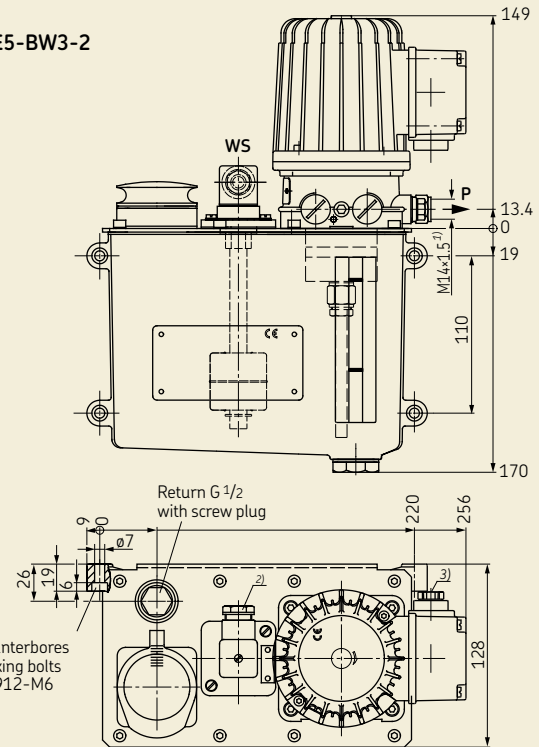

- 1) Port tapped for solderless tube connection, for 8 mm diam. tube
- 2) Connection for cable 7 to 9 mm diam.
- 3) Connection for cable 4 to 11 mm diam.

Fig. 7

MFE5-BW7

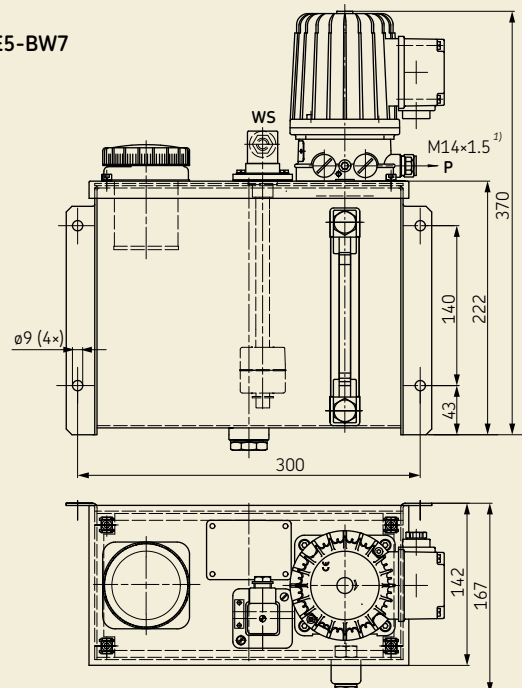

- 1) Port tapped for solderless tube connection, for 8 mm diam. tube

MFE5 gear pump unit with 3 or 6 liter plastic reservoir

Overview order No.

Order No. ⁴⁾	Flow rate [l/min]	Reservoir capacity [litres]	Reservoir material	Order No. without float switch
MFE5-KW3-2	0.5	3	plastic	MFE5-K3-2
MFE5-KW6	0.5	6	plastic	MFE5-K7

4) When ordering, the order no. should be supplemented with the power key.

Technical data

Float switch (WS) for monitoring the minimum level

Type of contact	1 changeover
Max. switching voltage	230 V AC / 230 V DC
Max. switching current	1.0 A
Max. switching capacity	60 VA / 40 W ⁵⁾
Type of enclosure	IP 65
Temperature range	-10 to +60 °C

5) Take appropriate measures to protect contacts when switching inductive loads.

See page 5 for further information.

Fig. 8

Hydraulic layout MFE5-KW3-2

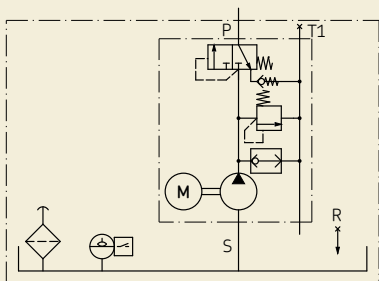
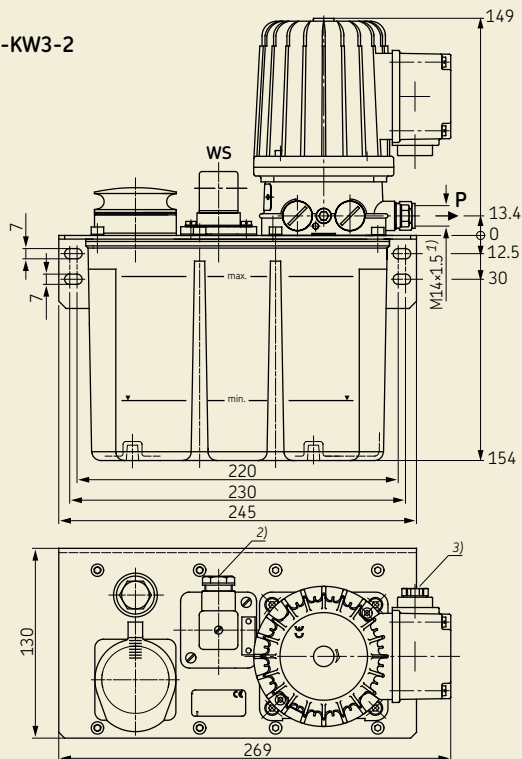

Fig. 9

MFE5-KW3-2



- 1) Port tapped for solderless tube connection, for 8 mm diam. tube
- 2) Connection for cable 7 to 9 mm diam.
- 3) Connection for cable 4 to 11 mm diam.

Fig. 10

MFE5-KW6

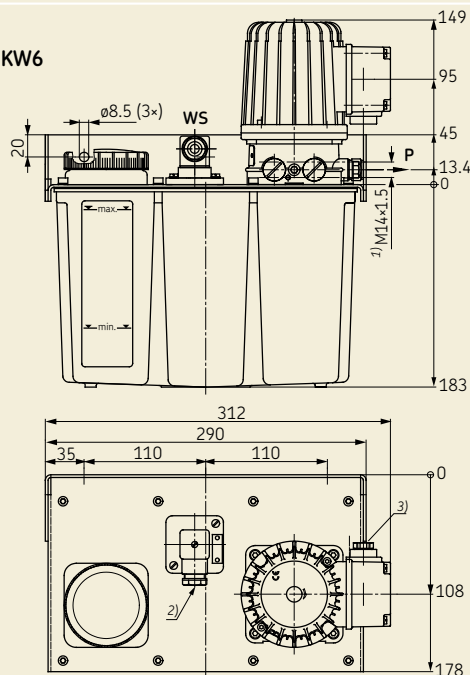

- 1) Port tapped for solderless tube connection, for 8 mm diam. tube
- 2) Connection for cable 7 to 9 mm diam.
- 3) Connection for cable 4 to 11 mm diam.

MFE5 gear pump unit with 15 liter sheet steel reservoir

Overview order No.

Order No. ³⁾	Flow rate [l/min]	Reservoir capacity [litres]	Reservoir material	Version
MFE5-BW16	0.5	15	sheet steel	foot-mounted reservoir
MFE5-BW15				reservoir

3) When ordering, the order no. should be supplemented with the power key.

Technical data

Float switch (WS) to monitor the critical level of oil with advance warning about 25 mm before the minimum oil level is reached.

Type of contact	2 changeover (reed contacts)
Max. switching voltage	230 V AC / 230 V DC
Max. switching current	0.8 A
Max. switching capacity	60 VA / 40 W ⁴⁾
Type of enclosure	IP 65
Temperature range	-10 to +60 °C

4) Take appropriate measures to protect contacts when switching inductive loads.

See page 5 for further information.

Fig. 11

Hydraulic layout MFE5-BW16

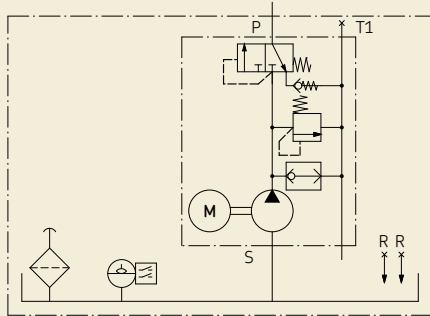

Fig. 12

Circuit diagram float switch (WS)



Bild 13

MFE5-BW16

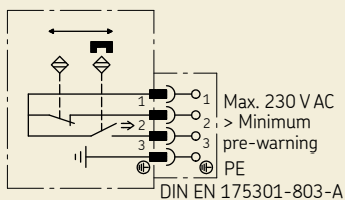
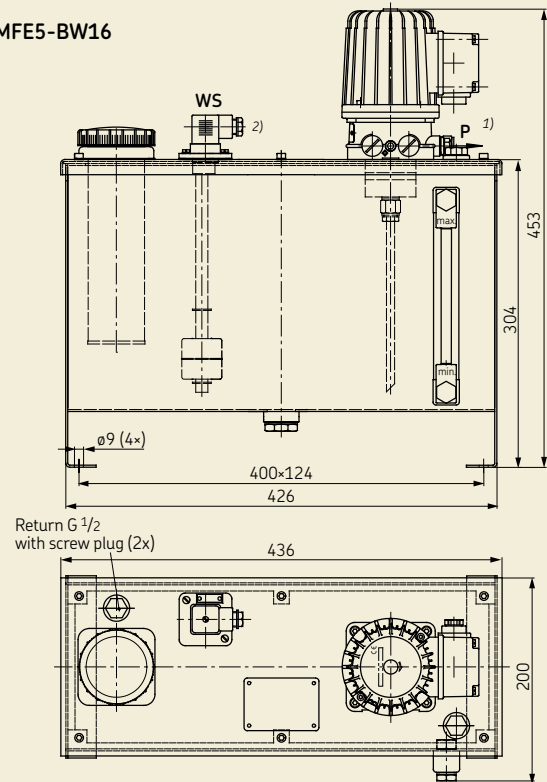

1) Port P tapped for solderless tube connection, M14×1.5 for 8 mm diam. tube.
2) Connection for cable 7 to 9 mm diam.

Fig. 14

Bracket for wall mounting Order No. 249-032.10

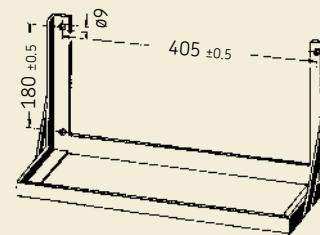

Function – float switch (WS)

About 25 mm before the minimum oil level is reached contact 1–3 closes.

When the minimum oil level is reached contact 1–2 opens in addition.

With plug-type connector to DIN EN 175301-803-A
Depicted: full reservoir

Other reservoir units and design on request.

Complete reservoir units according to customer request (eg. automotive regulations) are available.