

Accessories

Connection of motor and encoder Couplings Bellows and spring washer couplings



Bellows couplings provide cost-effective connection of the motor and encoder. They are also able to correct any angular errors between the drive and encoder.

Spring washer couplings are used with high speeds.

Order code	8.0000	. 1	XXX	. XX	XX
Couplings	Type		a	b	c
a Type of coupling					
102 = Bellows-type ø 19 mm [0.75"]					
202 = Bellows-type ø 15 mm [0.59"]					
301 = Spring washer type, ø 30 mm [1.18"], one-part					
401 = Spring washer type, ø 30 mm [1.18"], three part, plug-in					
502 = Bellows-type ø 25 mm [0.98"]					
b Bore diameter d1					
06 = 6 mm					
08 = 8 mm					
10 = 10 mm					
12 = 12 mm					
14 = 14 mm					
15 = 15 mm					
A1 = 3/8"					
A2 = 1/4"					
c Bore diameter d2					
04 = 4 mm					
06 = 6 mm					
08 = 8 mm					
10 = 10 mm					
12 = 12 mm					
A1 = 3/8"					
Example: d1 = 10 mm und d2 = 12 mm					
Order no. = 8.0000.1X0X.1012					
Stock types					
8.0000.1102.1010					
For possible combinations of d1/d2, see technical data					

Technical data		8.0000.1102.XXXX	8.0000.1202.XXXX	8.0000.1301.XXXX	8.0000.1401.XXXX	8.0000.1502.XXXX
Type		10000	10000	12000	12000	10000
Maximum speed	min ⁻¹	10000	10000	12000	12000	10000
Maximum torque	Ncm	120	40	80	60	200
Maximum displacement	radial	mm ± 0.3	± 0.25	± 0.4	± 0.3	± 0.35
	axial	mm ± 0.5	± 0.45	± 0.4	± 0.4	± 0.54
	angular	- ± 4°	± 4°	± 3°	± 2.5°	± 4°
Torsion spring stiffness	Nm/rad	150	85	150	30	183
Radial spring stiffness	N/mm	10	20	6	40	17.8
Moment of inertia	gcm ²	9.5	2.1	19	35	20
Max. tightening torque	Ncm	150	70	80	80	120
Working temperature		-30°C ... +120°C [-22°F ... +248°F]	-30°C ... +120°C [-22°F ... +248°F]	-30°C ... +120°C [-22°F ... +248°F]	-10°C ... +80°C [+14°F ... +176°F]	-30°C ... +120°C [-22°F ... +248°F]
Weight approx.		16 g [0.56 oz]	6.5 g [0.23 oz]	16 g [0.56 oz]	30 g [1.06 oz]	24 g [0.85 oz]
Material	flange	Al, anodized	Al, anodized	Al, anodized	Al, anodized	Al, anodized
	bellow or spring washer/casing	stainless steel	stainless steel	stainless steel	PA 6.6 gf.	stainless steel
Diameter d/d1 from ... to	mm [inch]	3 ... 12 [0.12 ... 0.47]	3 ... 9 [0.12 ... 0.35]	3 ... 8 [0.12 ... 0.32]	4 ... 16 [0.16 ... 0.47]	3 ... 16 [0.12 ... 0.63]
Standard bore diameter	(d1 / d2) mm [inch]	12 / 12 [0.47 ... 0.47]	08 / 06 [0.32 ... 0.24]	06 / 06 [0.24 ... 0.24]	12 / 12 [0.47 ... 0.47]	15 / 12 [0.59 ... 0.47]
		12 / 10 [0.47 ... 0.39]	06 / 06 [0.24 ... 0.24]		12 / 10 [0.47 ... 0.39]	14 / 12 [0.55 ... 0.47]
		10 / 10 [0.39 ... 0.39]	06 / 04 [0.24 ... 0.16]		10 / 10 [0.39 ... 0.39]	14 / 10 [0.55 ... 0.39]
		10 / 08 [0.39 ... 0.32]	04 / 04 [0.16 ... 0.16]		10 / 06 [0.39 ... 0.24]	10 / 10 [0.39 ... 0.39]
		10 / 06 [0.39 ... 0.24]			06 / 06 [0.24 ... 0.24]	06 / 06 [0.24 ... 0.24]
		08 / 08 [0.32 ... 0.32]			1/4" / 10	
		06 / 06 [0.24 ... 0.24]			1/4" / 06	
				3/8" / 3/8"		

Description and applications

Manufacturing and installation tolerances as well as the effects of temperature cause alignment errors between shafts in drive engineering which can sometimes lead to extreme overload on the bearings.

This may result in increased wear of the bearings and may lead to premature failure of the encoder. By using couplings, these alignment errors can be compensated, thereby reducing the load on the bearings to a minimum. A distinction should be made between three different kinds of alignment error: radial, angular and axial displacement.

Whilst with torsion-free but flexible shaft couplings, axial shaft displacements produce only static forces in the coupling, radial and angular displacements produce alternating stresses, restoring forces and moments which may have an impact on adjoining components (shaft bearings).

Depending on the type of coupling, particular attention should be paid to radial shaft displacement which should be kept to a minimum.

Accessories

Connection of motor and encoder	Couplings	Bellows and spring washer couplings
--	------------------	--

Metal bellows-type couplings (.1102, .1202 und .1502)

Metal bellows-type couplings are recommended as an inexpensive type of coupling. They are also suitable for compensating larger angle displacements.

Dimensions

Dimensions in mm

Bellows-type coupling $\varnothing 15$ [0.59]
(8.0000.1202.XXXX)

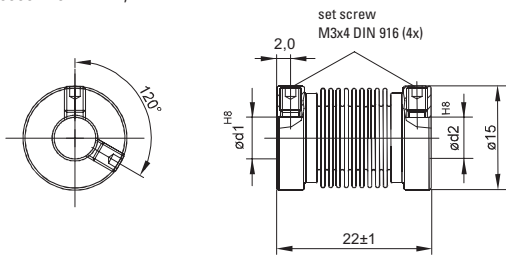

Bellows-type coupling $\varnothing 19$ [0.75]
(8.0000.1102.XXXX)

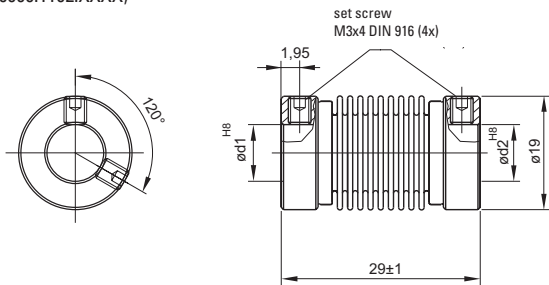

Bellows-type coupling $\varnothing 25$ [0.98]
(8.0000.1502.XXXX)

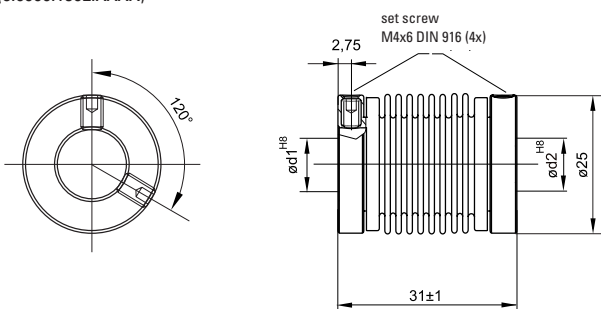

Spring washer-type couplings (.1301 und .1401)

Spring washer couplings are used primarily where high speeds and minimal axial errors occur. For applications requiring potential separation between the encoder and the drive, use the electrically isolating spring washer coupling.

Spring washer-type coupling, one-part
(8.0000.1301.XXXX)

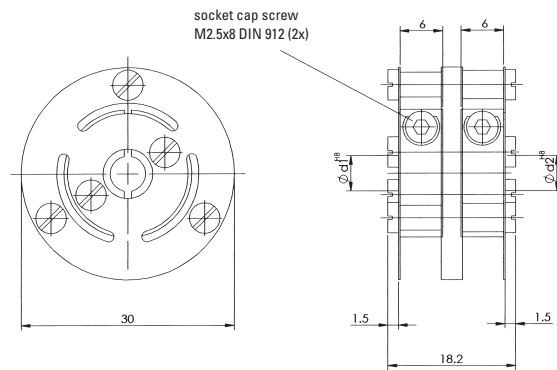

Spring washer-type coupling, three part, plug-in
(8.0000.1401.XXXX)

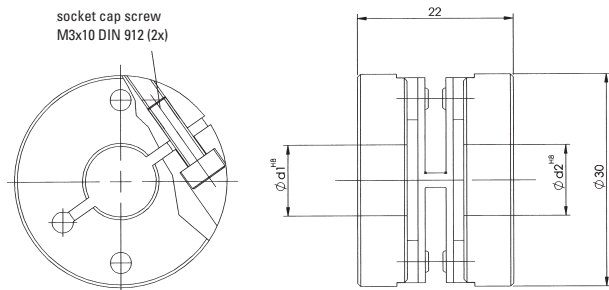

Installation instructions

1. Check shaft for displacement; see technical data for details.
2. Align and adjust coupling on shafts.
3. Tighten locking screws carefully. Avoid overtightening.
4. During installation protect the coupling from damage and from overbending.

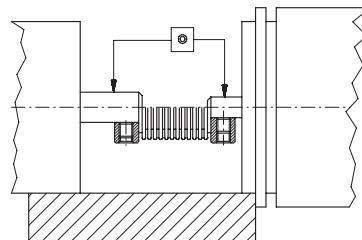

Accessories

Connection of motor and encoder **Couplings** **Bellows couplings (FS)**



Bellows couplings provide cost-effective connection of the motor and encoder. They are also able to correct any angular errors between the drive and encoder.

These bellows couplings (FS) are used for safe connection of applications and Sendix SIL encoders.

The safety-oriented bellows coupling has, in addition to the metallic bellows, internal claws that ensure the driving of the encoder in case of breakage of the bellows connection.

Order code Couplings	8.0000 Type	. 1 5 a	FS b	. XX XX c	
a Type of coupling	5 = bellows coupling ø 25 mm [0.98"]	b Bore diameter d1	10 = 10 mm 12 = 12 mm	c Bore diameter d2	10 = 10 mm 12 = 12 mm
					Example: d1 = 10 mm and d2 = 12 mm order no. = 8.0000.15FS.1012
For possible combinations of d1/d2, see technical data					

Accessory		Order no.
Screw retention	Loctite 243, 5 ml	8.0000.4G05.0000

Technical data

Mechanical characteristics	
Max. speed	10000 min ⁻¹
Max. torque	200 Ncm
Max. shaft offset	radial ± 0.3 mm axial ± 0.45 mm angular ± 3°
Torsion spring stiffness	183 Nm/rad
Radial spring stiffness	17.8 N/mm
Moment of inertia	9.1 gcm ²
Headless set screw tightening torque	min. 80 Ncm max. 100 Ncm

Working temperature range	-30°C ... +120°C [-22 ... +248°F]	
Weight approx.	54 g	
Material	flange	stainless steel 1.4104
	bellows	stainless steel 1.4571
Standard bore diameter	(d1 / d2)	10 / 10 mm [0.39 / 0.39"] 10 / 12 mm [0.39 / 0.47"] 12 / 12 mm [0.47 / 0.47"]
Insertion depth	min.	6 mm [0.24"]
	max.	11 mm [0.43"]

Dimensions

Dimensions in mm [inch]

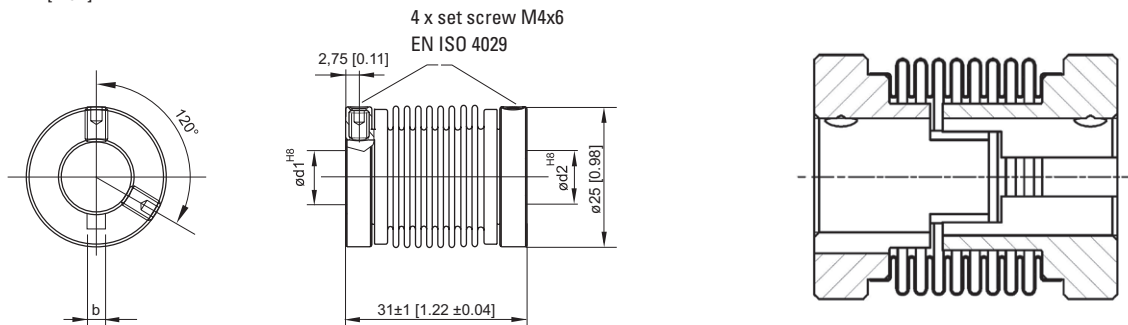

Nut DIN 6885

nut width b	d1 / d2
3 [0.12]	10 [0.39]
4 [0.16]	12 [0.47]

