

GMP252 Carbon Dioxide Probe For ppm-level measurements



Features

- Measurement range
0 ... 10 000 ppm CO₂
- Intelligent, standalone probe with analog and digital outputs
- Compatible with Vaisala Indigo products and Insight PC software
- Wide operating temperature range, -40 ... +60 °C (-40 ... +140 °F)
- IP65-classified housing
- Integrated temperature measurement for CO₂ compensation purposes
- Compensations also for pressure, oxygen, and humidity
- Sensor head heated to prevent condensation

Vaisala CARBOCAP® Carbon Dioxide Probe GMP252 is an intelligent probe for measuring carbon dioxide. This robust, standalone measurement device is designed for use in agriculture, refrigeration, greenhouses, and demanding HVAC applications.

Benefits

- Excellent long-term stability
- Reliable and accurate
- Calibration certificate included

GMP252 is suitable for harsh and humid CO₂ measurement environments where stable and accurate ppm-level CO₂ measurements are needed. GMP252 is based on Vaisala's patented, latest-generation CARBOCAP technology that enables exceptional stability. A new type of infrared (IR) light source is used instead of the traditional incandescent light bulb, which extends the lifetime of GMP252.

GMP252 incorporates an internal temperature sensor for compensation of the CO₂ measurement according to ambient temperature. The effects of pressure and background gas can also be compensated for. The measurement

range is 0 ... 10 000 ppm CO₂ (measurements up to 30 000 ppm CO₂ are available with reduced accuracy). The operating temperature range of the probe is wide (-40 ... +60 °C (-40 ... +140 °F)), and the probe housing is classified as IP65. Condensation is prevented as the internal sensor head is heated.

GMP252 is resistant to dust and most chemicals, such as H₂O₂ and alcohol-based cleaning agents.

Ease of use

GMP252 is a compact probe with easy and fast plug-in, plug-out installation. The surface of the probe is smooth, which makes it easy to clean. The probe provides several output options, including analog current and voltage outputs and digital RS-485 output with Modbus® protocol.

GMP252 can be connected to Indigo series transmitters and the Indigo80 handheld indicator for an extended range of outputs and configuration options. See

For easy-to-use access to field calibration, device analytics, and configuration functionality, the probe can be connected to Vaisala Insight software for Windows®. See [insight](#).

Applications

GMP252 is ideal for agriculture, refrigeration, greenhouses, and demanding HVAC applications where stable and accurate ppm-level CO₂ measurements are needed.

A flow-through adapter with gas ports is available as an accessory, enabling tubing for easy and flexible remote measurement with a separate pump. A multiplexer can also be added for sampling gas from several locations. ¹⁾

¹⁾ Third-party pump and multiplexer not provided by Vaisala.

Technical data

Measurement performance

Measurement range	0–10 000 ppm CO ₂ (up to 30 000 ppm CO ₂ with reduced accuracy)
Accuracy ¹⁾	
0–3000 ppm CO ₂	±40 ppm CO ₂
3000–10 000 ppm CO ₂	±2 % of reading
Up to 30 000 ppm CO ₂	±3.5 % of reading
Calibration uncertainty	
at 2000 ppm CO ₂	±31 ppm CO ₂
at 10 000 ppm CO ₂	±105 ppm CO ₂
Long-term stability	
0–3000 ppm CO ₂	±60 ppm CO ₂ /year
3000–6000 ppm CO ₂	±150 ppm CO ₂ /year
6000–10 000 ppm CO ₂	±300 ppm CO ₂ /year
Temperature dependence 0–10 000 ppm CO₂	
With compensation, –10 ... +50 °C	±0.05 % of reading/°C
With compensation, –40 ... +60 °C	< ±0.1 % of reading/°C
Without temperature compensation at 2000 ppm CO ₂ (typical)	–0.5 % of reading/°C
Pressure dependence	
With compensation at 0–10 000 ppm CO ₂ , 500–1100 hPa	±0.015 % of reading/hPa
Without compensation (typical)	+0.15 % of reading/hPa
Humidity dependence	
With compensation, 0–10 000 ppm CO ₂ , 0–100 %RH	±0.7 % of reading (at +25 °C (+77 °F))
Without compensation (typical)	+0.05 % of reading/%RH
O₂ dependence	
With compensation, 0–10 000 ppm %CO ₂ , 0–90 %O ₂	±0.6 % of reading (at +25 °C (+77 °F))
Without compensation (typical)	–0.08 % of reading/%O ₂
Start-up, warm-up, and response time	
Start-up time at +25 °C	< 12 s
Warm-up time for full spec.	< 2 min
Response time (T90):	
With standard filter	< 1 min
Flow-through option with > 0.1 l/min	30 s
With spray shield	< 3 min
Flow rate dependence (for flow-through option)	
< 1 l/min flow	No effect
1–10 l/min flow	< 0.6 % of reading l/min

¹⁾ At 25 °C (77 °F) and 1013 hPa (incl. repeatability and non-linearity).

Inputs and outputs

Analog outputs	<ul style="list-style-type: none"> 0–5/10 V (scalable), min. load 10 kΩ 0/4–20 mA (scalable), max. load 500 Ω
Digital output	Over RS-485: <ul style="list-style-type: none"> Modbus Vaisala Industrial Protocol
Operating voltage	
With digital output in use	12–30 V DC
With voltage output in use	12–30 V DC
With current output in use	20–30 V DC
Power consumption	
Typical (continuous operation)	0.4 W
Maximum	0.5 W

Operating environment

Operating temperature of CO ₂ measurement	–40 ... +60 °C (–40 ... +140 °F)
Storage temperature	–40 ... +70 °C (–40 ... +158 °F)
Operating humidity	0–100 %RH, non-condensing
Condensation prevention	Sensor head heating when power on
IP rating, probe body	IP65
Chemical tolerance (temporary exposure during cleaning)	<ul style="list-style-type: none"> H₂O₂ (2000 ppm, non-condensing) Alcohol-based cleaning agents (for example ethanol and IPA) Acetone Acetic acid
Pressure	
Compensated	500–1100 hPa
Operating	< 1.5 bar
Gas flow (for flow-through option)	
Operating range	< 10 l/min
Recommended range	0.1–0.8 l/min

Compliance

EU directives and regulations	EMC, RoHS
Electromagnetic compatibility (EMC)	EN 61326-1, basic electromagnetic environment
EMC emissions	CISPR 32 / EN 55032, Class B
Compliance marks	CE, RCM

Mechanical specifications

Weight, probe	55 g (1.94 oz)
Connector type	M12 5-pin male
Materials	
Probe housing	PBT polymer
Filter	PTFE
Dimensions	
Probe diameter	25 mm (0.98 in)
Probe length	130 mm (5.12 in)

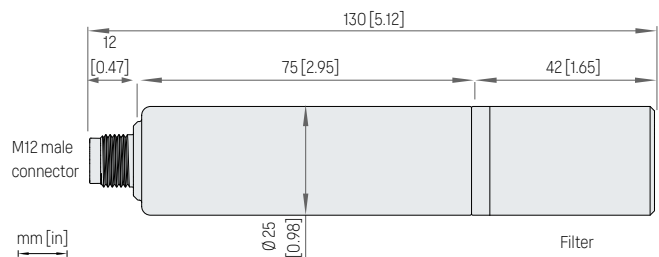

GMP252 probe dimensions

Spare parts and accessories

Porous sintered PTFE filter for GMP252	DRW244221SP
Probe connection cable with open wires (1.5 m), shielded	223263SP
Probe connection cable with open wires (1.5 m), shielded	254294SP
Probe connection cable with open wires (3 m), shielded	26719SP
Probe connection cable with open wires (10 m), shielded	216546SP
Probe connection cable with open wires and 90° plug (0.6 m), shielded	244669SP
Probe connection cable with open wires and 90° plug (1.5 m), shielded	255102
M170 connection cable, M12 5-pin	CBL210472
Connection cable for Indigo80, M12-5F - M12-5M, 1.5 m	272075SP
Flat cable for GMP250 probes, M12 5-pin	CBL210493SP
Indigo USB adapter ¹⁾	USB2
Probe mounting clips (2 pcs)	243257SP
Probe mounting flange	243261SP
Probe holder assembly	ASM213582
Probe handle with magnetic hanger	GMP252HANDLESP
Probe handle	ASM214342SP
Flow-through adapter with gas ports	ASM212011SP
Calibration adapter	DRW244827SP
Spray shield	ASM212017SP
Radiation shield DTR250	DTR250
Radiation shield DTR250 with pole mounting kit	DTR250A

¹⁾ Vaisala Insight software for Windows is available at www.vaisala.com/insight.

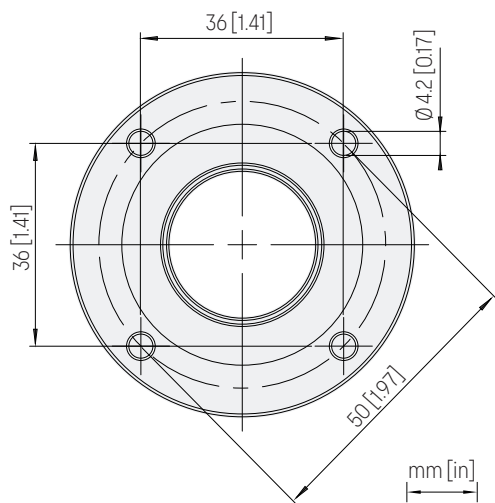

Probe mounting flange 243261SP dimensions

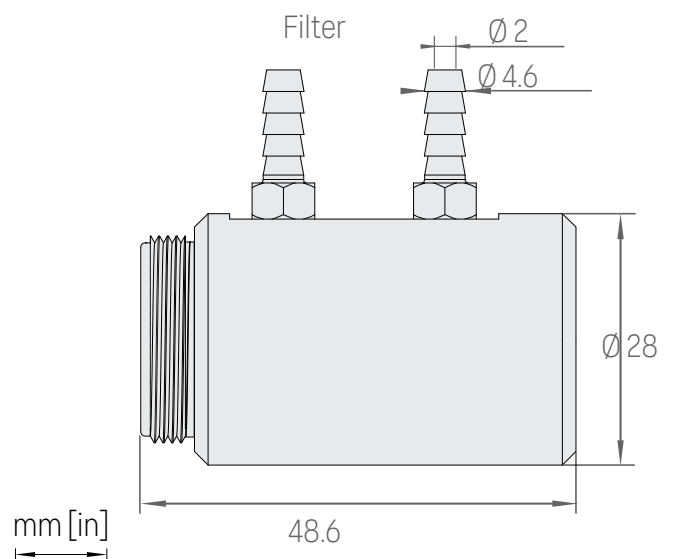

Flow-through adapter with gas ports ASM212011SP. Suitable for tubes with 4 mm inner diameter.

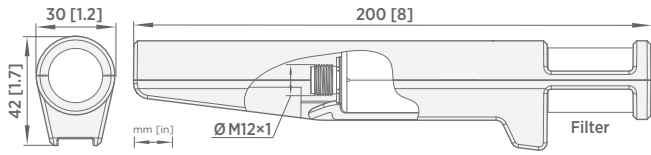

GMP252 probe handle dimensions

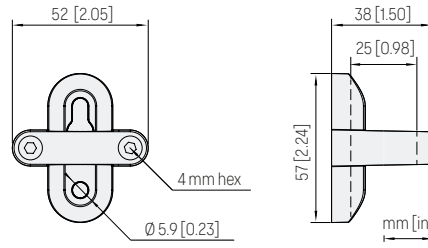

Probe holder ASM213582 dimensions

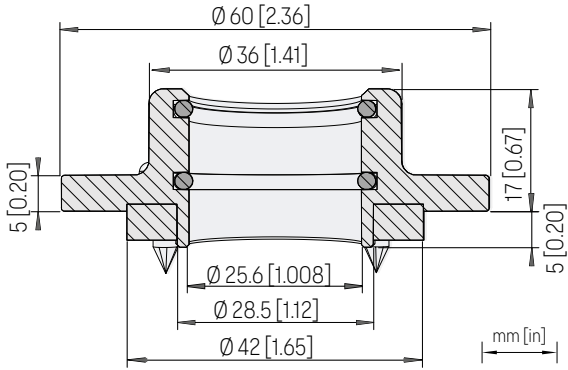

Probe mounting flange 243261SP dimensions, cross section