

NEWALL

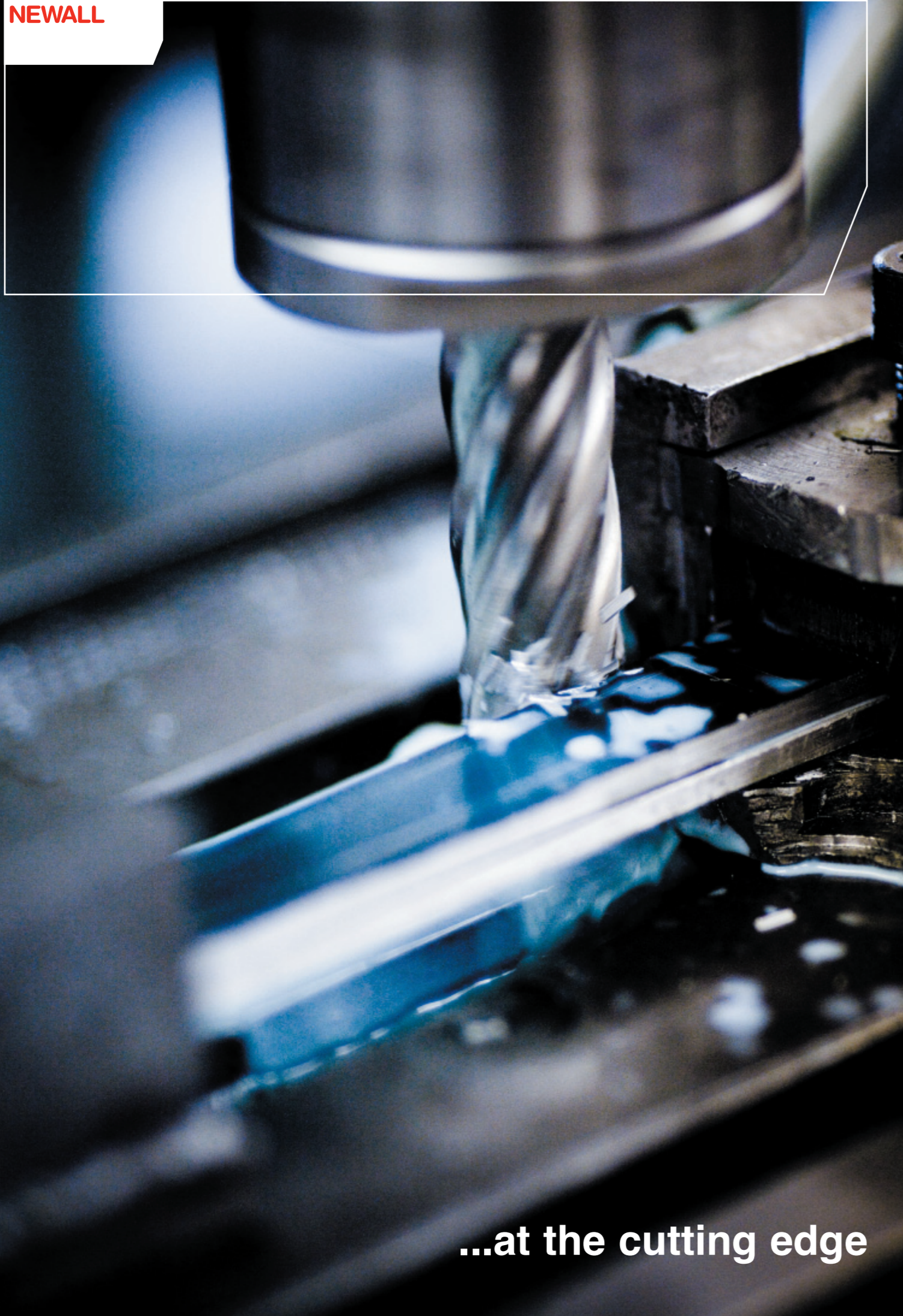

Linear Encoders

NEWALL



...at the cutting edge

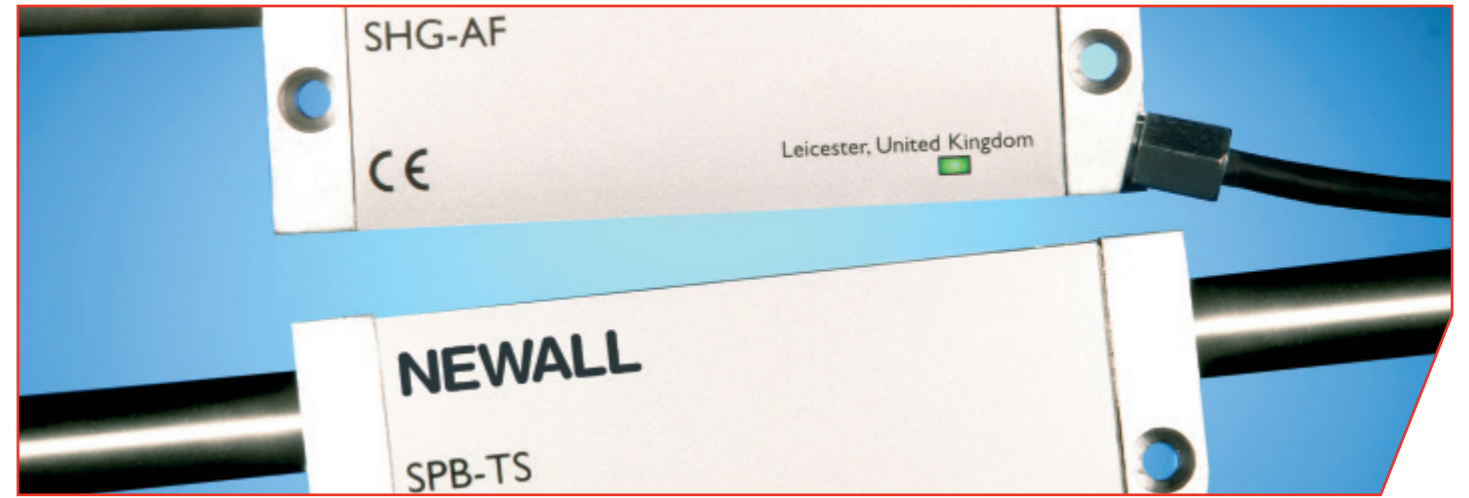

Company Profile

NEWALL

Newall was founded in Peterborough, England in 1968 and is now a division of CST (Custom Sensors & Technologies), a business unit of Schneider Electric. During this time, Newall has dedicated itself to providing the automation, machine tool and other machinery and production industries with leading edge technologies that increase productivity and machine tool efficiency.

Over the years Newall has grown to be a well respected leader in Digital Readout (DRO) and Linear Encoder technology. Newall's world renowned range of Digital Readout Systems (DROs) are specifically designed and dedicated to increasing machine productivity. Together with the Spherosyn™ and Microsyn™ Linear Encoders, they are some of the most advanced, market-leading readouts available on the market today.

Features

- IP67 rating (NEMA 6)
- Withstands dust, swarf, oil and other harsh environmental conditions
- No mechanical wear characteristics
- Requires no cleaning or maintenance
- High tolerance to shock and vibration
- High reliability

Linear Encoders

The range of Linear Encoders provided by Newall incorporate a truly unique design in that none of the electrical or measuring components are exposed to harsh workshop environments and they will continue to provide accurate and reliable readings even when fully submerged in water, oil and coolant. For this reason all of the Newall Linear Encoder range carry an IP67 (NEMA 6) environmental rating. This means they are dust tight and protected against the effects of total water immersion up to 1m.

The range includes incremental, absolute and distance-coded variants and are available with industry standard output signals which can be interfaced with all major CNC, NC, PLC and PC products.

IP Protection Levels

The chart clearly defines levels of IP ratings and should be used as a guide during the specification and design process.

1st IP#	Degree of protection against access to hazardous parts & ingress of solid objects	2nd IP#	Degree of protection against the ingress of water
0	No protection	0	No protection
1	Protected against solid foreign objects of 50mm Ø and >	1	Protected against vertically falling water drops
2	Protected against solid foreign objects of 12.5mm Ø and >	2	Protected against vertically falling water drops when enclosure tilted up 15°
3	Protected against solid foreign objects of 2.5mm Ø and >	3	Protected against spraying water
4	Protected against solid foreign objects of 1.0mm Ø and >	4	Protected against splashing water
5	Dust protected	5	Protected against water jets
6	Dust tight	6	Protected against powerful jets from any direction
		7	Protected against the effects of total water immersion up to 1M
		8	Protected against the effects of total water immersion beyond 1M

NEWALL



Linear Encoder Overview

Incremental Linear Encoders

Newall's Incremental Linear Encoders comprise of a scale and reader head that contains a coil assembly and supporting electronics, which provide quadrature square wave or sine-cosine feedback signals that allow for direct integration to servo driven applications. These encoders operate on the principle of electromagnetic induction. An electromagnetic field is generated by inducing a 10kHz sinusoidal current through a single drive coil within the reader head. This field interacts with the nickel chrome elements contained in the scale.

A set of four pickup coils detect variations in the induced field which are then combined and processed by the electronic circuitry to generate a signal that varies as the reader head moves along the scale. Depending on the position of the reader head as it passes over each element, the phase shift of this pickup signal relative to the drive signal will vary between 0 and 360 degrees. High speed Digital Signal Processing (DSP) converts the analogue signal to an industry standard signal, which also generates the periodic reference marker pulse.

Absolute Linear Encoders

Newall's Absolute Linear Encoders provide a true absolute position upon power up. The linear encoder does not use batteries or static memory to retain the position data.

Like Incremental Linear Encoders, the scale is comprised of a stainless steel tube that houses a column of precision nickel-chrome elements. For absolute and single point reference mark versions, coded scale inserts are placed between the elements in such a manner as not to interfere with the geometry of the system contact.

The Absolute Linear Encoder reader head also contains a sensor array that detects the target that is embedded in the coded scale inserts.

High speed digital signal processing is utilised in order to process the positional data and to communicate the output protocols.

Distance-Coded Linear Encoders

Newall's Distance-Coded Linear Encoders, using its internal absolute position count, can mimic the distance coded index marks that are generated by glass scales. An index pulse is generated at uniquely spaced intervals in the range of 4 to 10mm, varying by 20 micron increments. As the encoder is not constrained by any hardware limitations, it can calculate and output almost any sequence of marker pulses.

Encoder Selection Guide

Measuring Length	Measuring Accuracy**	Standard Resolution**	Page	Output Signal	Encoder Model
Incremental Linear Encoders					
Single Scale 12m*	±10µm	1µm	Page 14	TTL RS422 Differential Quadrature	SHG-TT
		20µm via SCC200	Page 14	1Vpp Signal Period 1Vpp Single Point Signal Period	SHG-VP SHG-VS
Modular 30m +	±10µm	1µm	Page 14	TTL Single Point RS422 Differential Quadrature	SHG-TS
				5-30V (Vin Vout) 5-30V (Open Collector)	SHG-PV SHG-PC
Up to 1m	±10µm	1, 5, 10µm	Page 24	TTL RS422 Single Point Differential Quadrature	SPB-TS
				TTL RS422 Differential Quadrature Periodic Point	SPB-TT
Up to 1m	±10µm	1µm	Page 16	TTL RS422 Differential Quadrature	MHG-TT
		20µm via SCC200	Page 16	1Vpp Signal Period	MHG-VP
Up to 1m	±5µm	1µm	Page 18	TTL RS422 Differential Quadrature	MCG-TT
				1Vpp 20µm Signal Period via SCC200 (included)	MCG-VP
Up to 22m	±25µm +20µm/m	10µm	Page 20	Magnetic Tape System	MAG-TS
Absolute Linear Encoders					
Up to 3.5m	±10µm	1µm	Page 22	RS485 + RS422 Differential Quadrature	SHG-A4
				SSI Binary + RS422 Differential Quadrature	SHG-AB
				SSI Gray Code + RS422 Differential Quadrature	SHG-AG
				RS232 + RS422 Differential Quadrature	SHG-A2
				Faunc	SHG-AF
				SSI Gray Code with Even Parity + RS422 Differential Quadrature	SHG-AS
SSI Gray Code with Even Parity + 1Vpp 20µm signal period via SCC200 (included)	SHG-AV				
Distance-Coded Linear Encoders					
Up to 3.5m	±5µm	1µm	Page 22	Distance-Coded TTL RS422 Differential Quadrature	SHG-TC

Notes to Selection Guide

All of these encoders can be connected to a wide range of PLC, CNC, NC and PC applications.

The choice of encoder depends on five principal factors:

1. The level of precision required for the application e.g., in general, a saw conveyor requires a lower level of precision than a grinding machine
2. Spatial limitations. The slim-line encoders can be fitted into smaller spaces than the full-sized encoders.
3. The overall measuring length of the application
4. The required resolution
5. The output signal

Accuracy defined as per meter

* For longer modular scale requirements refer to factory

** Further options for resolution and accuracy are available. Please refer to pages above

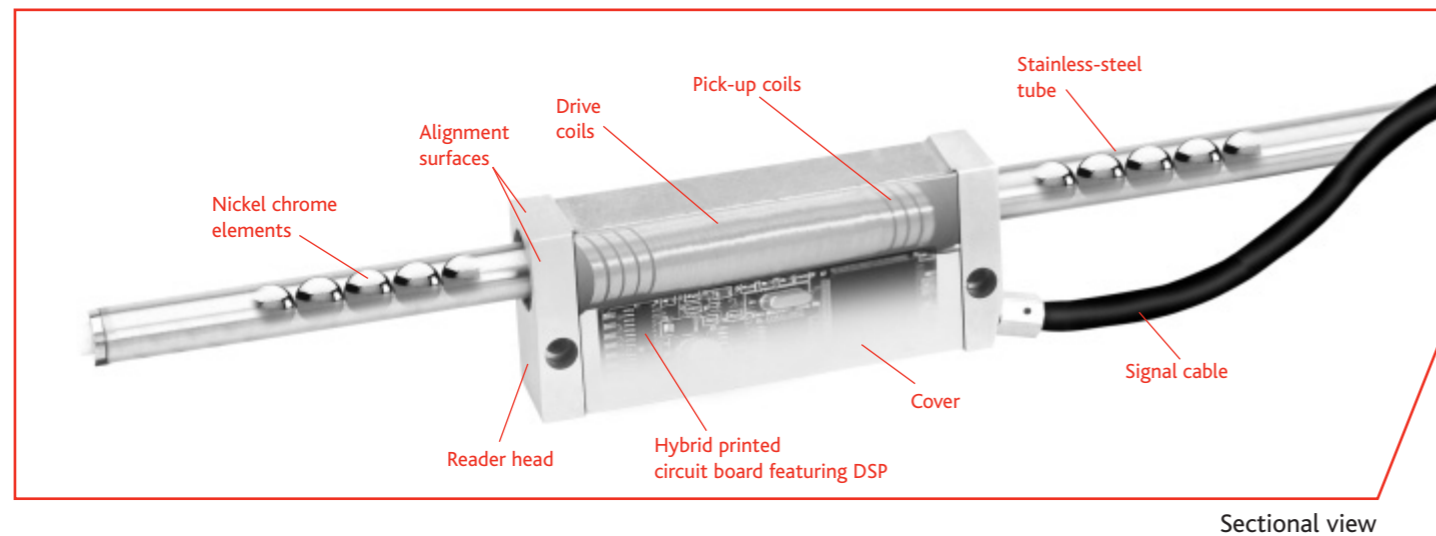

Sectional view

Newall's SHG technology is an inductive linear encoder, made up of two main assemblies; the reader head and the scale.

The scale is a stainless steel tube, housing a column of precision elements. The elements are maintained under compression; the compression load being set during manufacturing to calibrate the scale. The reader head, which fits around the scale, moves in a linear motion along the scale length comprising a rectangular aluminium casting containing a coil assembly and electronics.

Incremental

Figure 1 shows the arrangement of coils in the head. There are six sets of pick-up coils. Each set consists of four identical windings that are spaced at intervals of one pitch. As a result of this spacing each coil in a set is positioned over an identical part of an adjacent element. All the coils of a set are connected together in series. Over the pick-up coils is the drive coil. The elements within the scale cause the permeability of the scale to vary periodically over a pitch. The voltages induced in each of the sets of pick-up coils vary according to the relevant positions of the coils to the underlying elements.

The variation of the amplitude of the induced signals with displacement along the scale is shown in Figure 2a. The coils are spaced such that when one set of coils is at a maximum, (e.g. set A) another set spaced one half an element pitch away (set C) will be at a minimum. These coil pairs are combined differentially to produce signals that vary with displacement as shown in Figure 2b.

These combined signals are phase shifted by the electronic circuits in the head. The A-C signal is advanced 45° and the D-B signal is retarded 45°. These signals are added together and filtered. The result is an output signal whose phase varies as the head is displaced along the scale.

Figure 1 – Arrangement of Coils

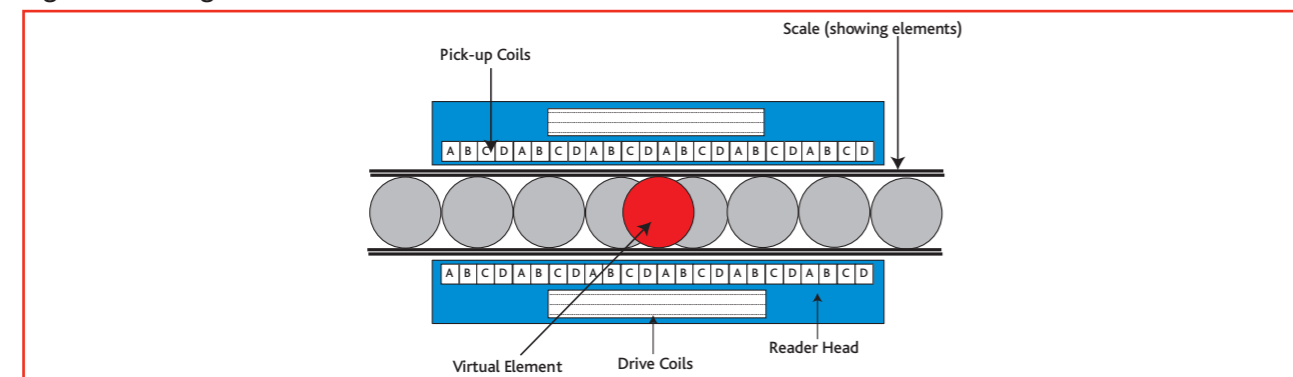

Figure 2a

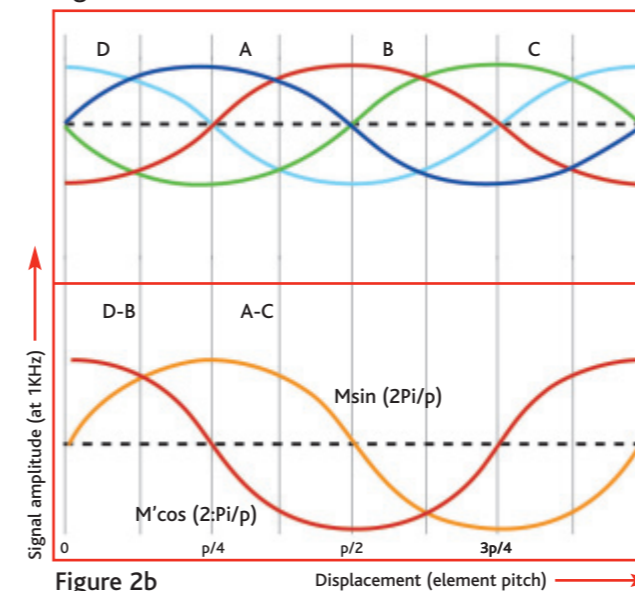
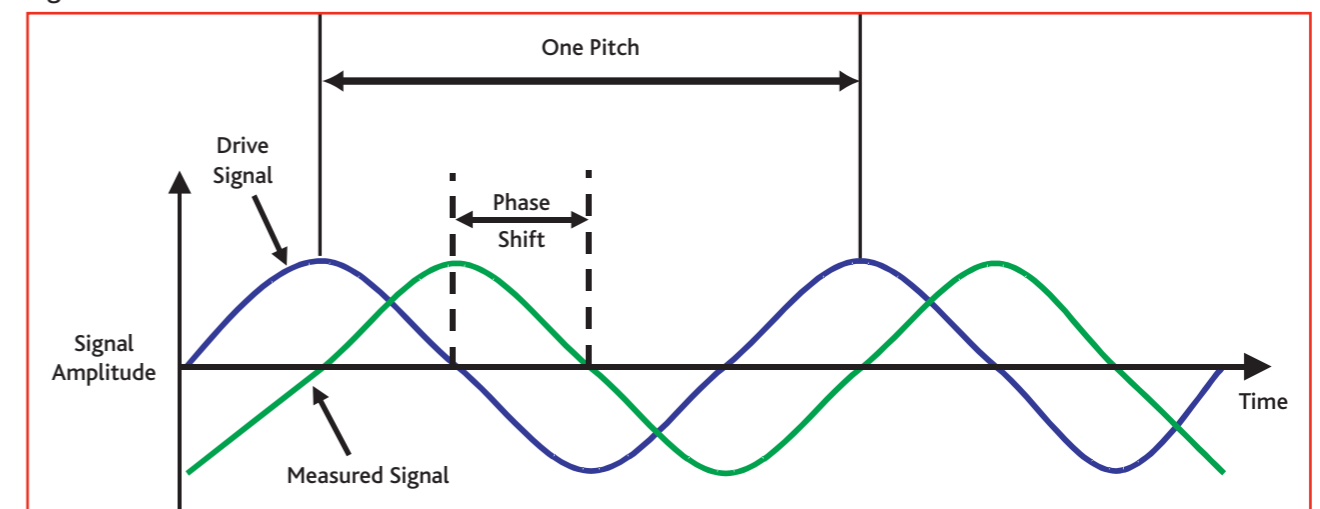

Figure 2b

The phase changes by 360° for each pitch of movement. This output signal is at the fundamental frequency of 10kHz and has a peak to peak amplitude of approximately 5V and a DC level of around 5V. Thus the position measured is absolute over a single element, i.e., for every 12.7mm increment. Figure 3 shows a phase shift of 90° that equates directly to a position of 3.175mm (1/4 of a pitch) relative to the zero phase position. To achieve linear measurement the total position is constructed by the addition of the absolute measurement value and the sum of the number of elements traversed since the encoder was referenced.

Encoders of position sensors can be broadly categorised into two families, DC operation or AC operation. In the DC operation lie optical and magnetic encoders, both rotary and linear. Devices that use AC operation are either inductive or capacitive. Examples of rotary inductive devices are resolvers and syncros whilst linear devices include LVDTs, Inductosyn and Newall Linear Encoders.

Figure 3



In AC systems, the signals containing the positional data are modulated AC signals at the fundamental operating frequency of the device. In DC systems the signals are modulated DC, i.e., slowly varying DC levels.

DC signals are particularly subject to offset errors, drift and low frequency noise.

Offset errors can be countered by the use of technique chopper stabilisation which, effectively, converts the signal to AC to eliminate the offset and then converts back. **In AC systems the nulling of offset errors is inherent in the AC coupling used and no complex techniques need be applied.**

Drift is a problem in DC systems, particularly optical where the lamps, LEDs or solar cells are subject to long term ageing. **Inductive systems are inherently stable being based on fixed physical properties such as turn ratios and permeability of the encoder parts. These do not change with time.**

Low frequency noise, particularly mains power frequencies, can interfere with DC signals and cannot be blocked without severely degrading the system's response time. **AC systems, working at a precise, fixed frequency, will employ low and high frequency filters without impacting upon response speed.**

A criticism often aimed at inductive encoders is that their relatively long pitch length requires a much larger interpolation level for a given resolution than for an optical grating. This is true but, it is not mentioned that accurate interpolation is much more easily achieved, for the reasons given above, on AC systems than DC. **The accuracies and resolutions that can be obtained from resolvers match those of their optical rotary counterparts.** The same is true for Newall's linear encoders versus its linear optical or magnetic competitors.

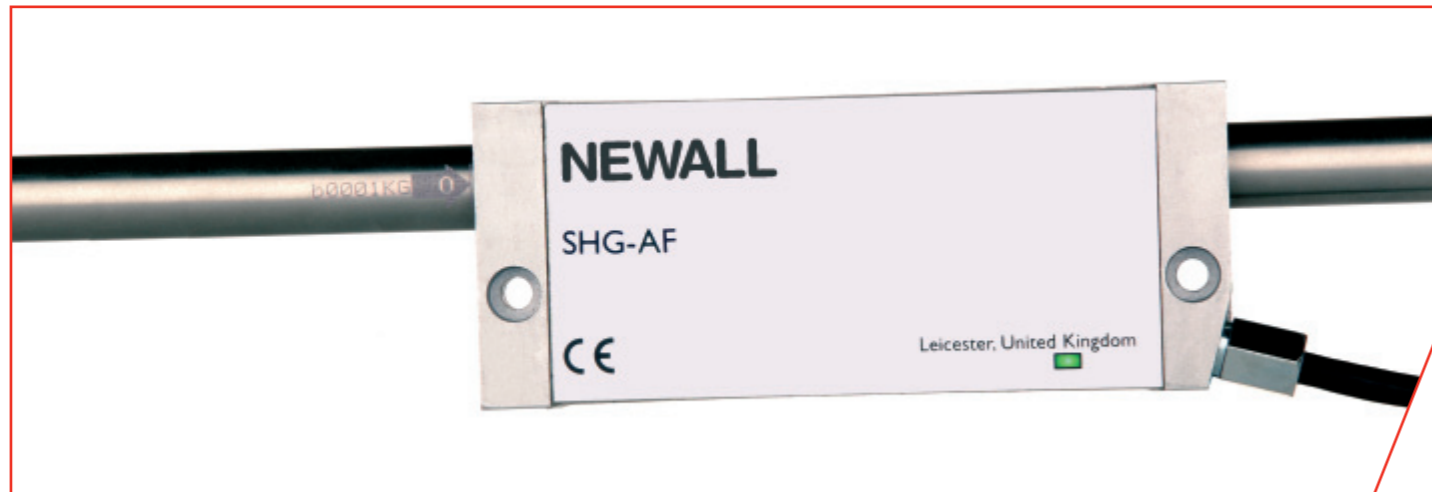

Absolute

The Newall Absolute Linear Encoder is a breakthrough in linear measurement technology. Uniquely coded inserts are placed between the precision nickel chrome elements in the scale. The inserts are locked in position as part of the manufacturing process and contain a small magnetic target that can be detected by a series of hall sensors contained within the reader head. The density of the inserts and the detectors within the reader head allows the system to determine absolute position on power up.

Once the encoder has internally determined the true absolute position it is then a matter for the DSP processing to handle communications of the positional data to the outside world through the use of communications protocols such as SSI (Synchronous Serial Interface), Fanuc, RS232, RS485 etc. Furthermore, the internal positional information can be used to accurately emulate other forms of Pseudo-Absolute interfaces such as Distance-Coded.

Being a Digital Sound Processor (DSP) based absolute system capable of a high level of processing, the encoders are error mapped during manufacturing against a laser interferometer. This error map is stored in FLASH memory allowing it to be applied in real-time thus resulting in a highly accurate system.

Distance-Coded

Distance-Coded reference markers allow the controller to acquire absolute position by moving the encoder system across two uniquely spaced reference marks. By using its internal absolute position count, a variant of the Absolute can mimic the Distance-Coded index marks that are generated by glass scales.

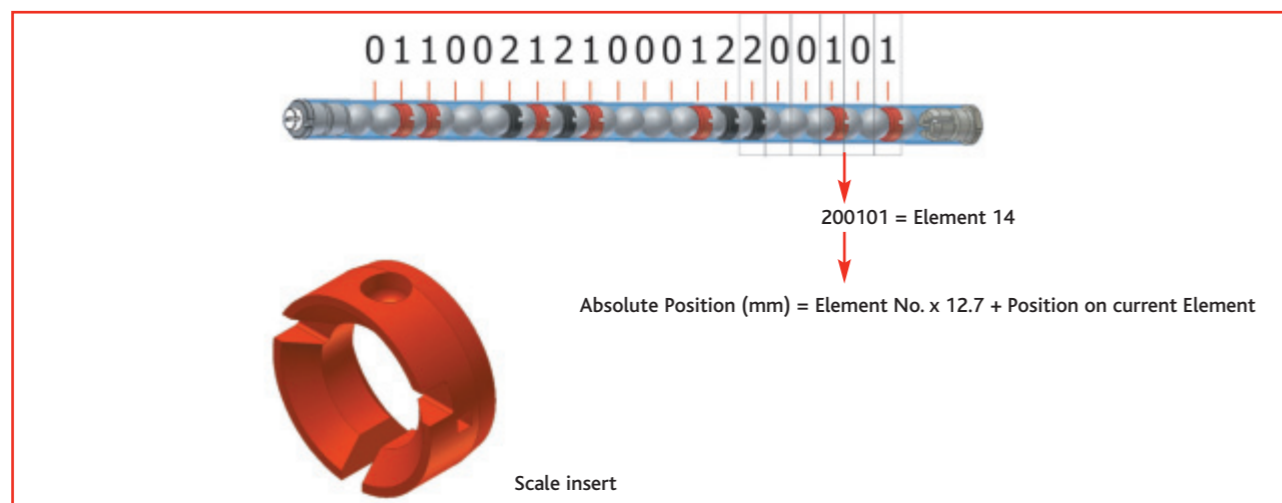

Magnetic Tape

The Newall MAG-TS encoder comprises of a flexible tape scale which is mounted on a fixed surface of the machine, with or without an optional twin track backing bar, and a reader head which is fastened to the moving part to be measured; arranged such that it travels in alignment with the scale.

The flexible nature of the tape scale makes the encoder ideal for rotary as well as linear applications.

For ease of installation, the adhesive side of the tape is attached directly to a machined surface. For applications where the mounting surface is uneven, the tape scale can be attached to an optional twin track backing bar, supported by stand-offs.

A stainless steel cover strip is supplied to protect the encoded tape. The cover strip is attached to the encoded tape by way of adhesive backing.

Principal of Operation

The tape scale is made up of a flexible magnetic rubber strip, sandwiched between a backing strip and a cover strip made from thin stainless steel. The encoded tape contains magnetic markers that are placed at intervals along the length of the tape.

As the incremental sensor in the reader head passes over the tape, the magnetic field is converted to an electrical signal, which is sampled by a micro controller. The field between the markers varies sinusoidally, with which the micro controller determines the position of the sensor in relation to each marker.

Reference Mark (RM)

One index marker (short lengths of tape containing just one magnetic pole pair) can be fitted in the second track of the optional backing bar. This is detected by the index sensor in the reader head and output as the RM signal. More than one reference mark can be supplied on request.

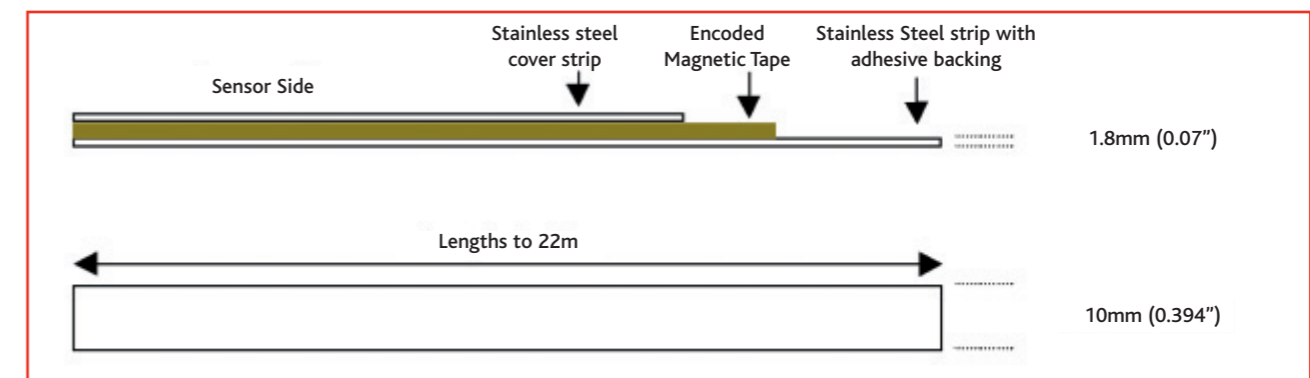

Encoder Outputs - Incremental

TTL Differential Quadrature (ordering code TT)

Newall TT Series Linear Encoders provide a differential quadrature output at TTL RS422 levels. The output signals are transmitted via a 9-core cable in accordance with the pin-out table below.

The periodic Reference Mark (RM) is synchronised with the A and B signals as shown in the diagram.

The distance between two successive edges of the combined pulse trains A and B is one measuring step (resolution).

TT - TTL - Differential Quadrature

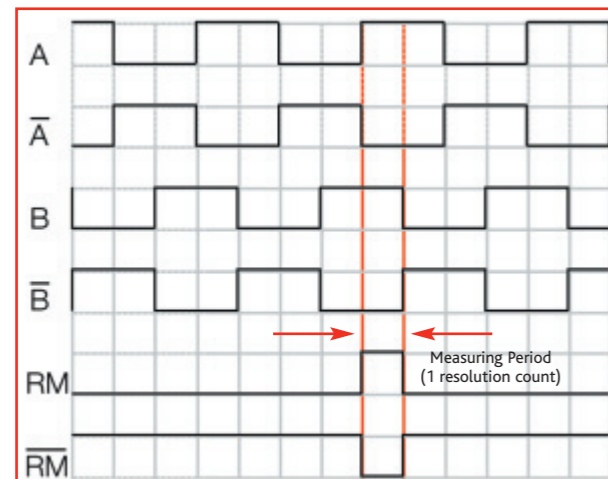

Encoder Connections

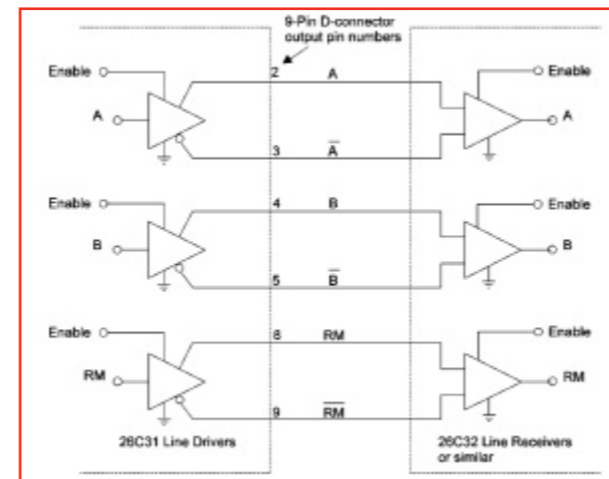

Connector D type 9 pin	- TT Incremental Output		
	Core	Function	Colour
1	7/0.15mm	Reserved, Do Not Connect	Orange
2	7/0.15mm	Channel A	Green
3	Twisted Pair	Channel \bar{A}	Yellow
4	7/0.15mm	Channel B	Blue
5	Twisted Pair	Channel \bar{B}	Red
6	7/0.25mm	0V	White
7	7/0.25mm	5V	Black
8	7/0.15mm	Channel RM	Violet
9	Twisted Pair	Channel \bar{RM}	Grey
GND	Screen	GND	---

Encoder Outputs - Incremental

Single Point TTL RS422 Differential Quadrature (ordering code TS) and Single Point 1Vpp (ordering code VS)

The SHG-TS and SHG-VS linear encoder scales have a series of up to eight selectable reference markers spaced every 25.4mm, starting 78.5 from the end of the scale. The reference point selected is dependent on the rotational alignment of the scale relative to the reader head on installation. An installation LED, bio-colour green and red, is mounted on the reader head encoder face. Available with TTL output (TS) or 1Vpp output when used with the SCC 200 converter (VS).

Distance-Coded TTL RS422 Differential Quadrature (ordering code TC)

The SHG-TC Linear Encoders provide a unique output reference marker every 10mm of movement along the length of the scale. This allows the absolute position value to be captured by the controller having moved over a maximum distance of 20mm. This removes the requirement to traverse the full length of the scale to pick up the single point index and establish the alignment position.

1Vpp via SCC200 Signal Converter (included) (ordering code VP)

Refer to section entitled Sine-Cosine Converter

Newall Signal Codes	Signal Type	Description	Available on
TT	Incremental TTL	TTL, RS422 Differential Quadrature output	SHG, MHG, SPB, MCG, MAG
TC	Incremental TTL-DC	TTL, Distance Coded	SHG
TS	Incremental TTL-SP	TTL Single Point	SHG, MHG, SPB
VP	Incremental ~1Vpp	1 Volt Peak to Peak	SHG, MHG, MCG
VS	Incremental ~1Vpp-SP	1 Volt Peak to Peak - Single Point	SHG
A2	Absolute - RS232	RS232	SHG
A4	Absolute - RS485	RS485	SHG
AB	Absolute - SSI-Binary	Synchronous Serial Interface - Binary Code	SHG
AF	Absolute - Fanuc	Fanuc Interface Protocol	SHG
AG	Absolute - SSI-Gray	Synchronous Serial Interface - Gray Code	SHG
AS	Absolute - Gray & Parity	Synchronous Serial Interface - Gray Code plus Even Parity Checksum	SHG

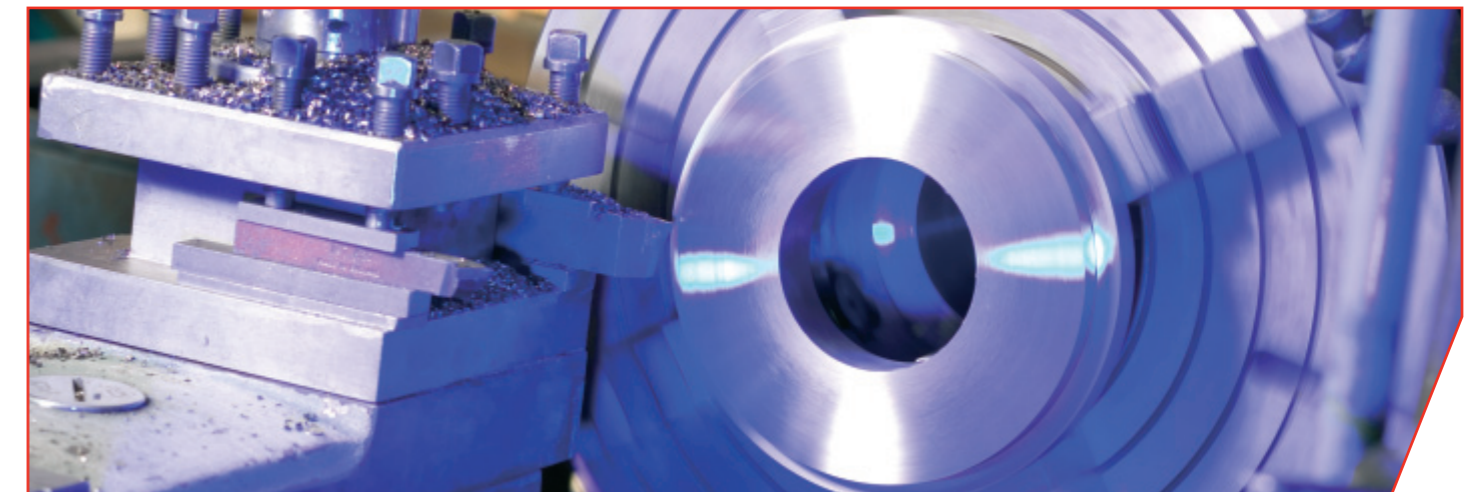

Encoder Outputs - Absolute

RS232 + RS422 Differential Quadrature (ordering code A2)

RS232 is a serial communication typically used to interface with PC control systems 'COM' port. This Electronics Industry Association (EIA) standard allows for data transmission from one transmitter to one receiver at data rates up to 20K bits/second and distances up to approximately 15m at the maximum data rate. A USB to serial converter (Newall part number 307-82340) is available to allow serial interface via a USB port.

RS485 + RS422 Differential Quadrature (Ordering code A4)

The RS485 standard is a multipoint communication network, which specifies up to 32 drivers and 32 receivers on a single 2-wire Bus. A key feature is the ability to address individual devices. Newall's Linear Encoders are capable of being given and remembering a unique address tag which means multiple devices can be hung off the RS485 Bus. (Please specify address tag when ordering).

Absolute Fanuc (ordering code AF)

This protocol is proprietary to Fanuc and available on all of their control systems. The controller makes a request for positional data and the encoder has to respond correctly with data within a strictly controlled time state.

SSI Output Format

The SSI (Synchronous Serial Interface) is a patented absolute interface by Max Stegmann GmbH. Newall's absolute encoders offer this interface implementing the 24 bit Gray code or Binary positional encoding. An even parity checksum is available on the AS & AV version. The Most Significant Bit (MSB) is transmitted first (D23).

The following absolute encoders are available with an SSI output:

- Absolute SSI Binary, 24 Bit (ordering code AB)
- Absolute SSI Gray, 24 Bit (ordering code AG)
- Absolute SSI Gray, 24 Bit with Even Parity (ordering code AS or AV)
(Parity is transmitted last and is Even Parity)

SSI is a serial protocol that provides absolute positional feedback for encoder applications. The SSI is a synchronous standard, meaning that the clock signals for the data exchange are provided by the controller and are typically limited to 1.5MHz. Transfer rates (baud) are also dependent on cable lengths. The following table is recommended.

Cable Length (m)	Baud Rate (KHz)
< 50	≥ 400
< 100	≥ 300
<200	≥ 200
<400	≥ 100

Binary is the position in decimal converted to its binary equivalent and then expanded with additional zero's to fill the required data packet. For example:

123456 (Decimal) = 11110001001000000 (Binary)

If this is shown in a 24 bit data packet it will equal:
000000011110001001000000

Gray is a binary code that only varies by one bit per transition.

Example:

0000
0001
0011
0010
0110 etc.

So the position in decimal is converted to pure binary and the converted to its Gray code equivalent. This has the advantage over binary in that the maximum reading error is a single step.

Encoder Outputs - Absolute

Signal Connection Table

Connector	Absolute Output					
	D Type 15 Pin	-A2 RS232	-A4 RS485	-AB & -AG SSI-Gray / SSI Binary	-AS Gray & Parity	-AV SSI & ~1Vpp
1				SSI CLK	SSI CLK	Details on page 27 Connection details via SCC200
2	Reserved, do not connect	Reserved, do not connect	Reserved, do not connect	Reserved, do not connect	Reserved, do not connect	
3	RS232 TX	RS232 TX				
4	\overline{RM}	\overline{RM}		\overline{RM}	\overline{RM}	
5	\overline{B}	\overline{B}		\overline{B}	\overline{B}	
6	\overline{A}	\overline{A}		\overline{A}	\overline{A}	
7	RS232 RX	RS232 RX				
8	+5VDC	+5VDC		+5VDC	+5VDC	
9				SSI \overline{CLK}	SSI CLK	
10		RS485		SSI DATA	SSI DATA	
11		$\overline{RS485}$		SSI \overline{DATA}	SSI \overline{DATA}	
12	RM	RM		RM	RM	
13	B	B		B	B	
14	A	A		A	A	
15	0V			0V	0V	

Blank connections are not implemented and are to be left unconnected

Signal Connection Table for Fanuc Serial Absolute

Connector	-AF Fanuc
PCE - E20FS HONDA	
5	Fanuc RQ
9, 18, 20	+5VDC
6	Fanuc \overline{RQ}
1	Fanuc Data
2	Fanuc \overline{Data}
12, 14, 16	0V

Product Incremental Linear Encoders

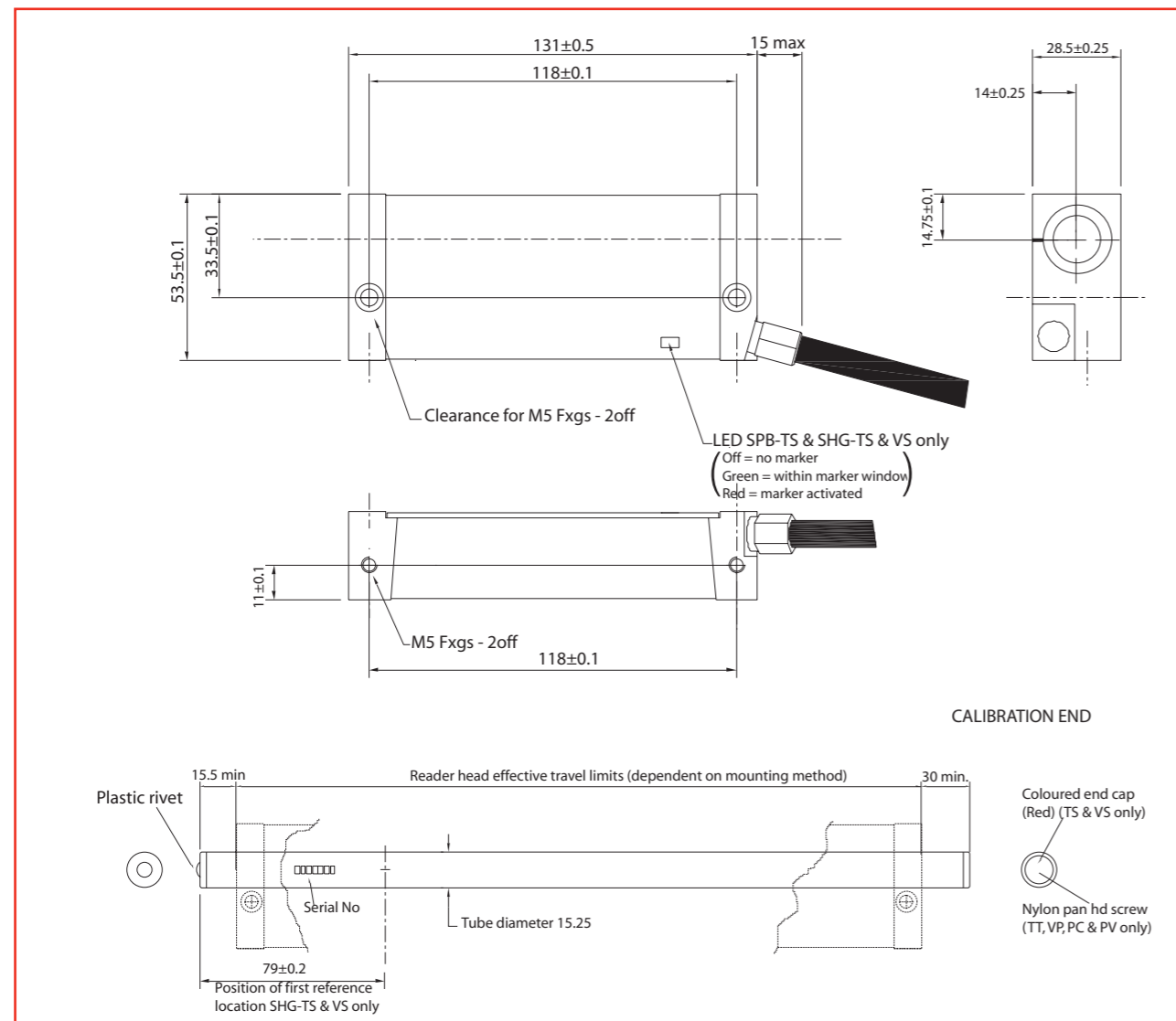

Product Incremental Linear Encoders

Specification	SHG-TT, SHG-VP, SHG-PC, SHG-PV	SHG-TS, SHG-VS	Options
Type	Inductive	Inductive	
Accuracy Grade	±10µm (±0.0004in)	±10µm (±0.0004in)	
Resolutions (µm/m)	1µm	TS = 1µm VS = 20µm via SCC200	0.5, 2, 5 & 10µm
Resolutions (in)	0.00005in	0.0005in	0.00002in 0.0001in 0.0002in 0.0005in
Reference Type	Periodic	Single Point	
Reference Location	Every 12.7mm (0.5in)	User select from 1 to 8 every 50.8mm (where scale travel permits)	
Maximum Traverse Rate	SHG-TT = 2m/s at 1µm resolution SHG-VP = 4m/s at 1µm resolution SHG-PC = 2m/s at 1µm resolution SHG-PV = 2m/s at 1µm resolution	SHG-TS = 2m/s at 1µm resolution SHG-VS = 4m/s 20µm Signal Period with SCC200	
Maximum Acc. / Dec.	100g / 98m/s (head moving)	100g / 98m/s (head moving)	
Power Supply	5VDC ± 5% <80mA	5VDC ± 5% <80mA	
Shock (11ms)	100g / 980m/s ² (IEC 69-2-6)	100g / 980m/s ² (IEC 69-2-6)	
Vibration (55-2000Hz)	30g / 294m/s ² (IEC 68-2-27)	30g / 294m/s ² (IEC 68-2-27)	
Ingress Protection (IP) Level	IP67, fully submersible (IEC 529) - Exceeds NEMA 6	IP67, fully submersible (IEC 529) - Exceeds NEMA 6	
Operating Temperature Range	0 to 55°C (32 to 131°F)	0 to 55°C (32 to 131°F)	
Storage Temperature Range	-20 to 70°C (-4 to 158°F)	-20 to 70°C (-4 to 158°F)	
Magnetic Field Susceptibility	100mT (1000 Gauss)	100mT (1000 Gauss)	
Radiated Magnetic Field	Less than 1mT	Less than 1mT	
Overall Cross-Section	53.5 x 28.5mm (2 x 1in)	53.5 x 28.5mm (2 x 1in)	
Scale Material	Stainless Steel	Stainless Steel	
Co-efficient of Expansion	12ppm/°C	12ppm/°C	
Scale OD	15.25mm (0.6in)	15.25mm (0.6in)	
Maximum Scale Travel	12,000mm (472in)*	12,000mm (472in)*	
Maximum Single End Mount Measuring Length	350mm (14in)	350mm (14in)	
Maximum Length between Supports	1500mm (59in)**	1500mm (59in)**	
Scale Over-Travel Requirements	254mm (10in)	254mm (10in)	
Standard Cable	9 core screened cable with PUR (polyurethane) cover with no armour	9 core screened cable with PUR (polyurethane) cover with no armour	Fully interlocked stainless steel armour
Cable Length	0.5m (20in)	0.5m (20in)	
Minimum Bend Radius with PUR	25mm (1in)	25mm (1in)	With Armour 50.8mm (2in)
Maximum Cable Length	22m (866in)	22m (866in)	
Connector	SHG-TT, SHG-VP, SHG-VV, SHG-VM = D type 9 pin (IP54, NEMA 3) SHG-PC, SHG-PV = 15 Pin D Type (IP54, NEMA 3)	D type 9 pin (IP54, NEMA 3)	SHG-TT, SHG-VP, SHG-TS, SHG-VS = 12 pin (IP67, NEMA 6), SHG-PC, SHG-PV = 19 Pin (IP67, NEMA 6)
EMC Compliance	BS EN 50081-2 & BS EN 50082-2	BS EN 50081-2 & BS EN 50082-2	

* Longer scale travels are available on request
** Only applies for travels over 2540mm (100 in)

Product Incremental Linear Encoders

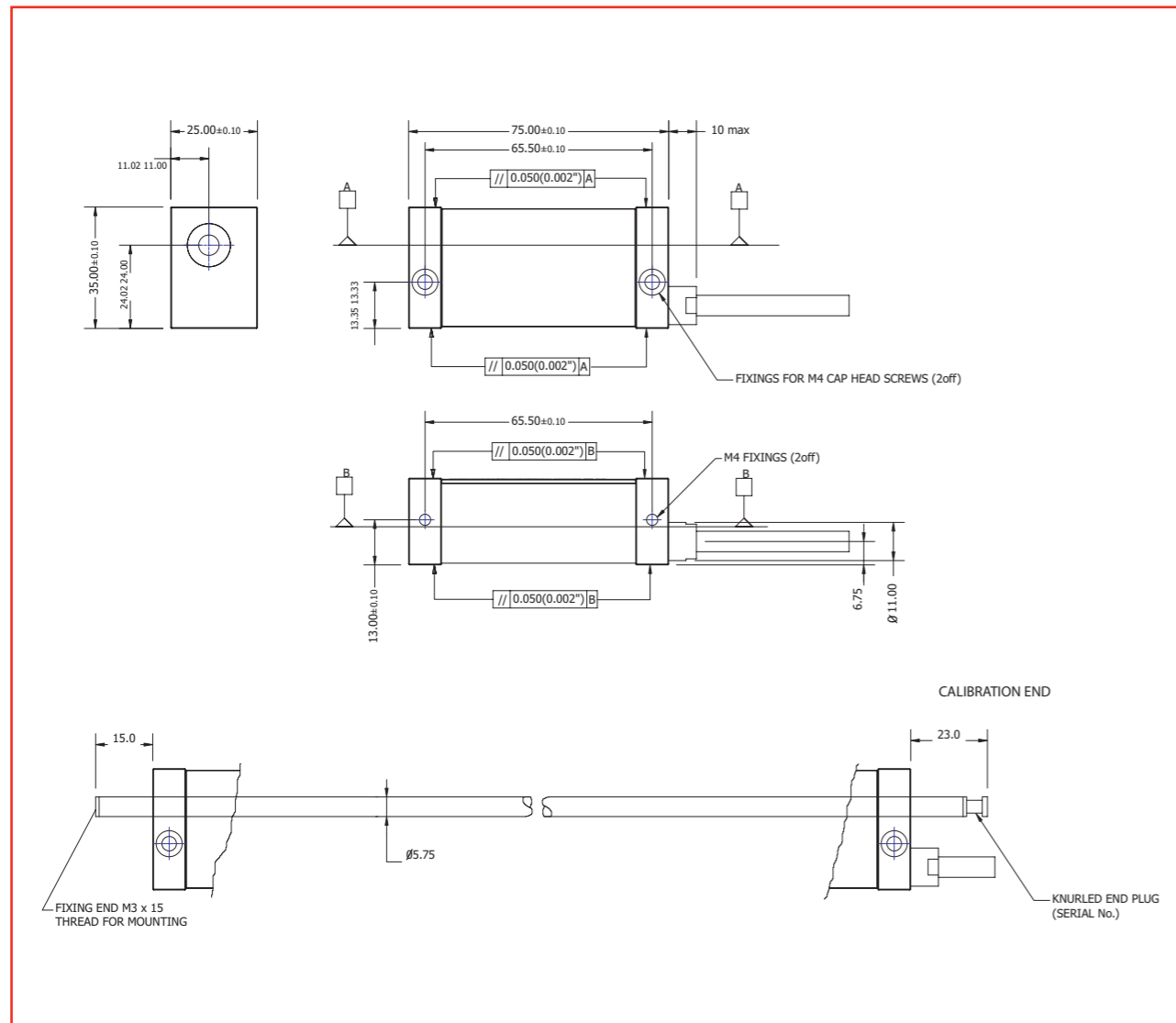

Product Incremental Linear Encoders

Specification	MHG-TT, MHG-VP	Options
Type	Inductive	
Accuracy Grade	±10µm	±5µm
Resolutions (µm/m)	TT = 1µm VP = 20µm via SCC200	0.1, 0.2, 0.5, 2, 5 & 10µm
Resolutions (in)	TT = 0.0005in	0.00005in 0.00001in 0.00002in 0.0001in 0.0002in 0.0005in
Reference Type	Periodic	
Reference Location	Every 5mm (0.2in)	
Maximum Traverse Rate	MHG-TT = 2m/s at 1µm resolution MHG-VP = 4m/s at 1µm resolution	
Maximum Acc. / Dec.	10g / 98m/s (head moving)	
Power Supply	5VDC ± 5% <80mA	
Shock (11ms)	100g / 980m/s ² (IEC 69-2-6)	
Vibration (55-2000Hz)	30g / 294m/s ² (IEC 68-2-27)	
Ingress Protection (IP) Level	IP67, fully submersible (IEC 529) - Exceeds NEMA 6	
Operating Temperature Range	0 to 55°C (32 to 131°F)	
Storage Temperature Range	-20 to 70°C (-4 to 158°F)	
Magnetic Field Susceptibility	100mT (1000 Gauss)	
Radiated Magnetic Field	Less than 1mT	
Overall Cross-Section	35 x 25mm (1.5 x 1in)	
Scale Material	Carbon Fibre	Stainless steel
Co-efficient of Expansion	12ppm/°C	
Scale OD	5.75mm (0.2in)	
Maximum Scale Travel	1000mm (39in)	
Maximum Single End Mount Measuring Length	250mm (10in)	
Scale Over-Travel Requirements	178mm (7in)	
Standard Cable	9 core screened cable with PUR (polyurethane) cover with no armour	Fully interlocked stainless steel armour
Cable Length	0.5m (20in)	
Minimum Bend Radius with PUR	25mm (1in)	With Armour 50.8mm (2in)
Maximum Cable Length	22m (866in)	
Connector	D type 9 pin (IP54, NEMA 3)	12 pin (IP67, NEMA 6), Round type
EMC Compliance	BS EN 50081-2 & BS EN 50082-2	

Product Incremental Linear Encoders

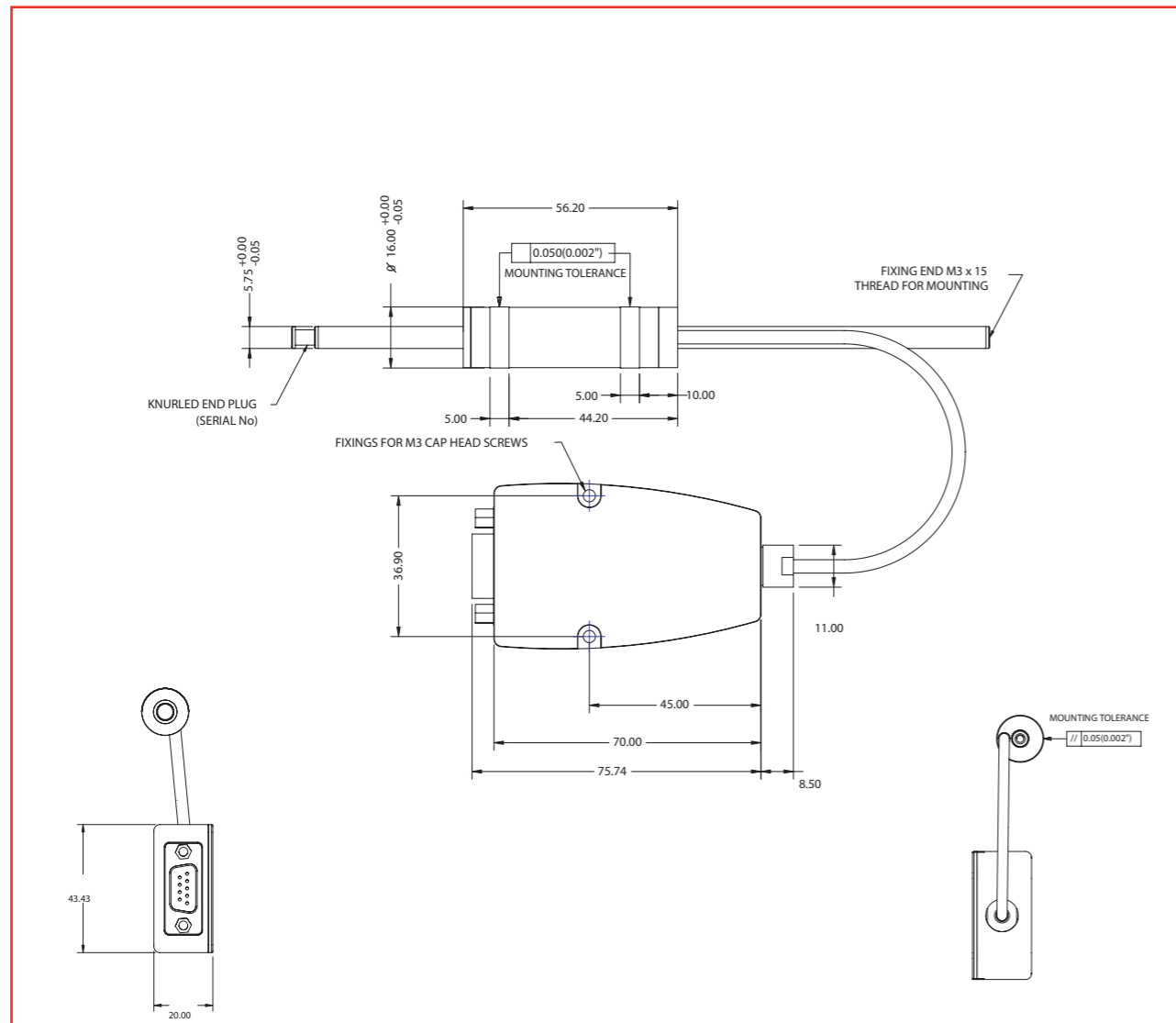
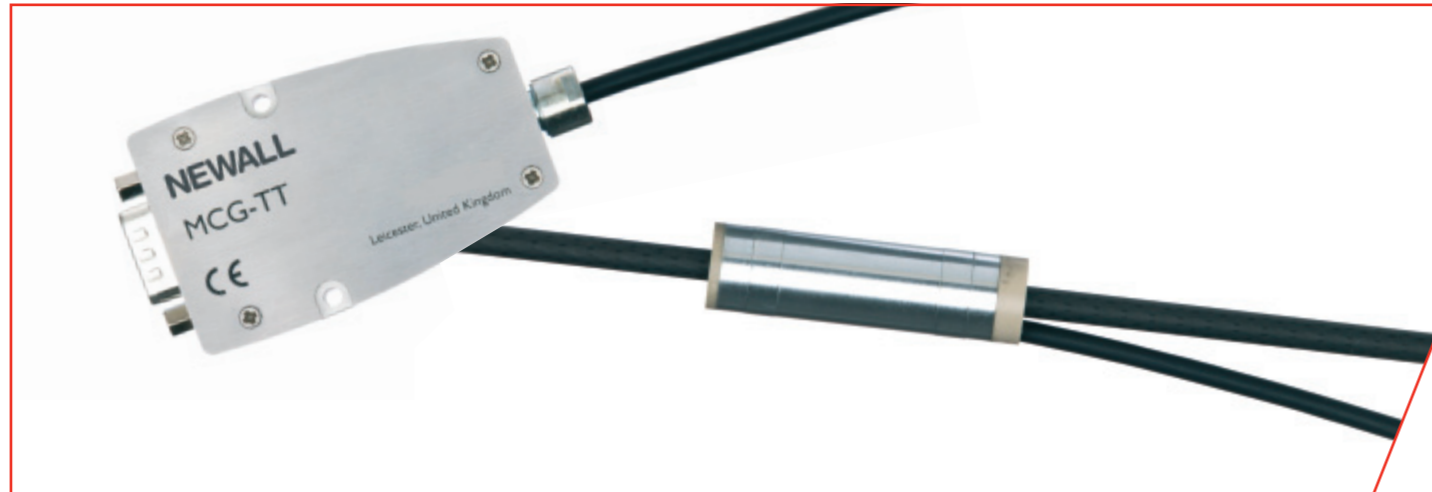

Product Incremental Linear Encoders

Specification	MCG-TT	Options
Type	Inductive	
Accuracy Grade	±5µm (± 0.0002in)	
Resolutions (µm/m)	1µm	0.1, 0.2, 0.5, 2, 5 & 10µm
Resolutions (in)	0.0005in	0.00005in 0.00001in 0.00002in 0.0001in 0.0002in 0.0005in
Reference Type	Periodic	
Reference Location	Every 5mm (0.2in)	
Maximum Traverse Rate	2m/s at 1µm resolution	
Maximum Acc. / Dec.	10g / 98m/s (head moving)	
Power Supply	5VDC ± 5% <80mA	
Shock (11ms)	100g / 980m/s ² (IEC 69-2-6)	
Vibration (55-2000Hz)	30g / 294m/s ² (IEC 68-2-27)	
Ingress Protection (IP) Level	IP67, fully submersible (IEC 529) - Exceeds NEMA 6	
Operating Temperature Range	0 to 55°C (32 to 131°F)	
Storage Temperature Range	-20 to 70°C (-4 to 158°F)	
Magnetic Field Susceptibility	100mT (1000 Gauss)	
Radiated Magnetic Field	Less than 1mT	
Overall Cross-Section	56.2mm x 16.0mm/OD (2.21in x 0.63in/OD)	
Scale Material	Carbon Fibre	Stainless steel
Co-efficient of Expansion	12ppm/°C	
Scale OD	5.75mm (0.2in)	
Maximum Scale Travel	1000mm (39in)	
Maximum Single End Mount Measuring Length	250mm (10in)	
Scale Over-Travel Requirements	178mm (7in)	
Standard Cable	9 core screened cable with PUR (polyurethane) cover with no armour	
Cable Length	0.5m (20in)	
Minimum Bend Radius with PUR	25mm (1in)	
Maximum Cable Length	22m (866in)	
Connector	D type 9 pin (IP54, NEMA 3)	12 pin (IP67, NEMA 6)
EMC Compliance	BS EN 50081-2 & BS EN 50082-2	

Product Incremental Linear Encoders - MAG-TS Magnetic Tape System

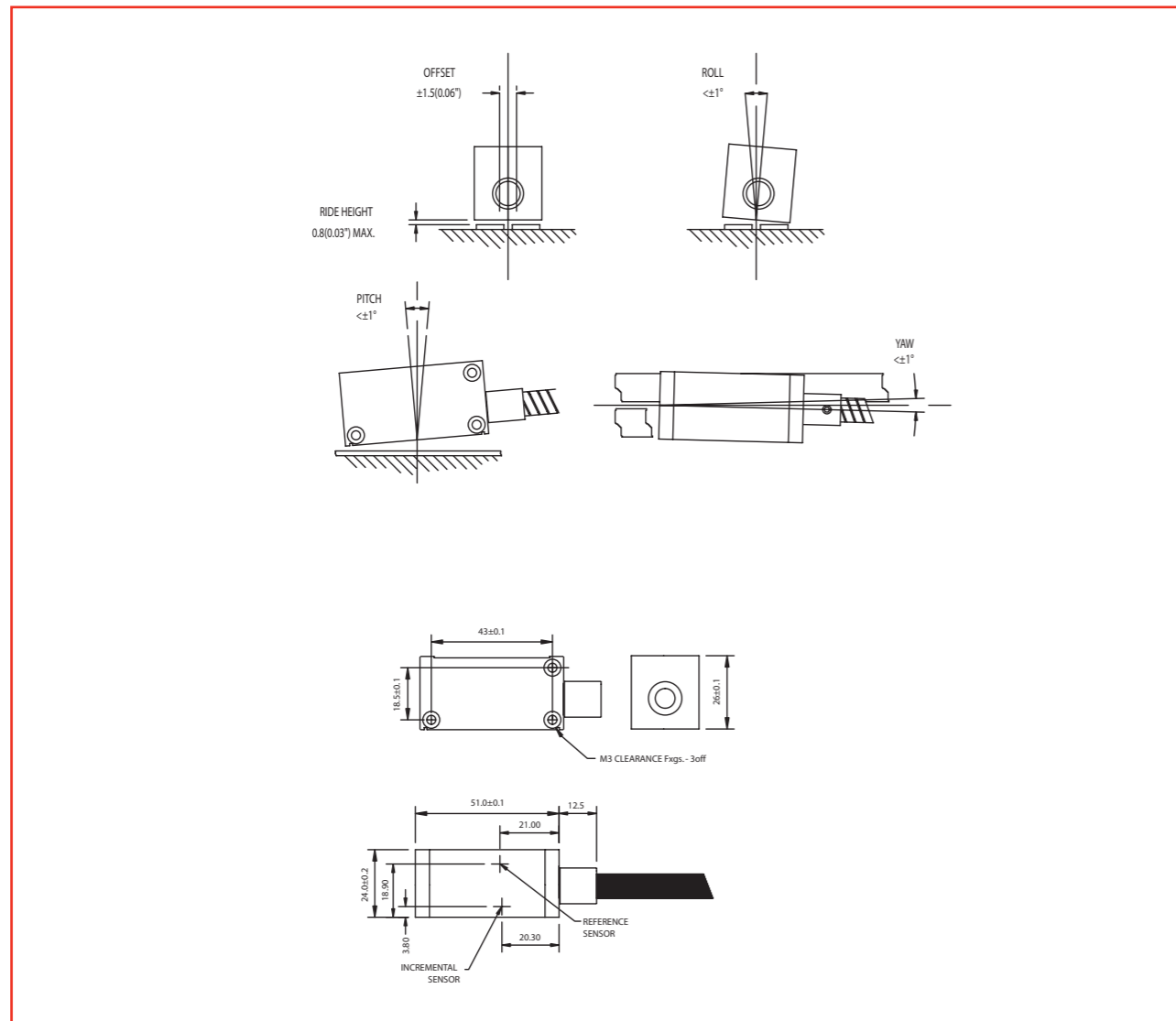

Product Incremental Linear Encoders - MAG-TS Magnetic Tape System

Specification	MAG-TS	Options
Type	Magnetic Tape	
Accuracy Grade	±25µm +20µm (0.001in)	
Resolutions (µm/m)	10µm	5µm
Resolutions (in)	0.0005in	0.0002in
Reference Type	Single	Additional RM available
Reference Location	User Select	
Maximum Traverse Rate	4m/s at 10µm resolution	4m/s at 5µm resolution
Maximum Acc. / Dec.	100g / 980m/s (head moving)	
Power Supply	5VDC ± 5% <80mA	
Shock (11ms)	100g / 980m/s ² (IEC 69-2-6)	
Vibration (55-2000Hz)	30g / 294m/s ² (IEC 68-2-27)	
Ingress Protection (IP) Level	IP67, fully submersible (IEC 529) - Exceeds NEMA 6	
Operating Temperature Range	0 to 55°C (32 to 131°F)	
Storage Temperature Range	-20 to 70°C (-4 to 158°F)	
Magnetic Field Susceptibility	5mT (50 Gauss)	
Radiated Magnetic Field	9mT (90 Gauss @ 0.6mm)	
Overall Cross-Section	24 x 26mm (1 x 1in)	
Scale Material	Rubber and Stainless Steel	
Co-efficient of Expansion	16ppm/°C	
Scale Section	10 x 1.8mm (0.4 x 0.07in)	
Maximum Scale Travel	20m (787in)	
Standard Cable	9 core screened cable with PUR (polyurethane) cover with fully interlocked stainless steel armour	
Cable Length	3.5m (138in)	
Minimum Bend Radius with PUR	With Armour 50.8mm (2in)	
Maximum Cable Length	22m (866in)	
Connector	D type 9 pin (IP54, NEMA 3)	
EMC Compliance	BS EN 50081-2 & BS EN 50082-2	

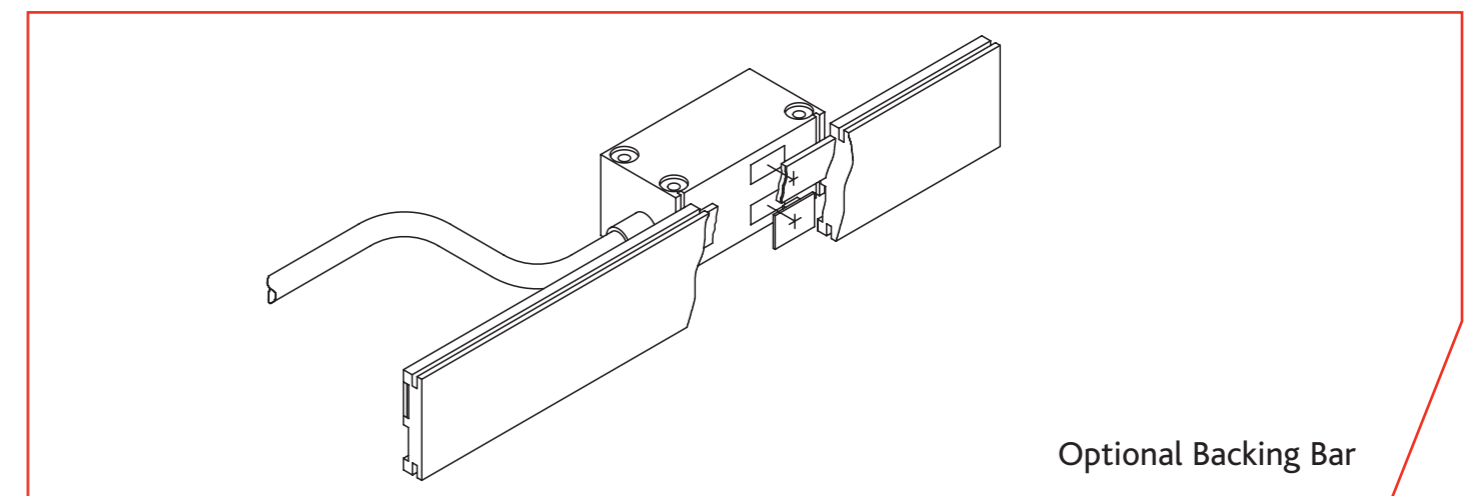

Optional Backing Bar

Product Absolute and Distance-Coded Linear Encoders

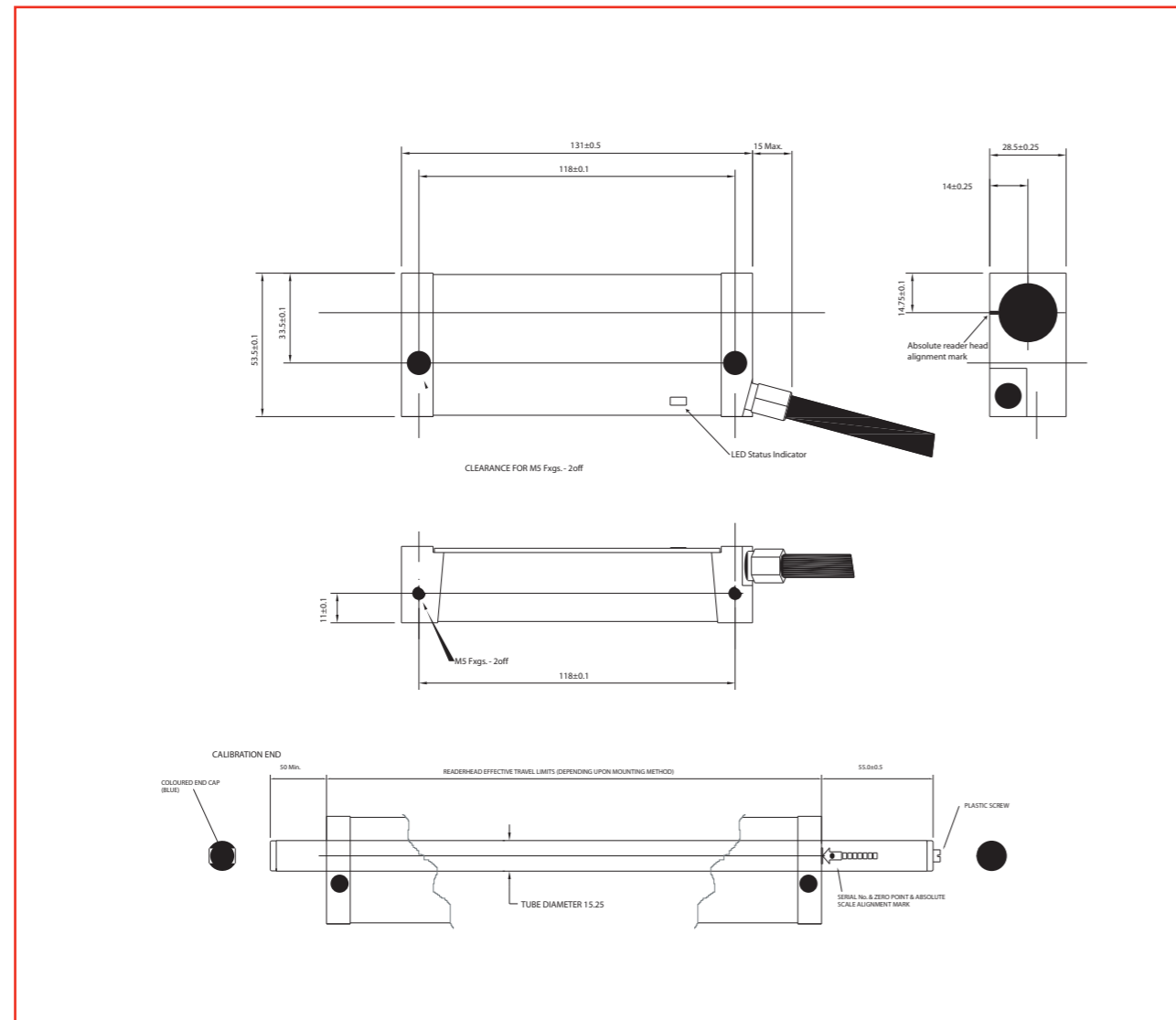
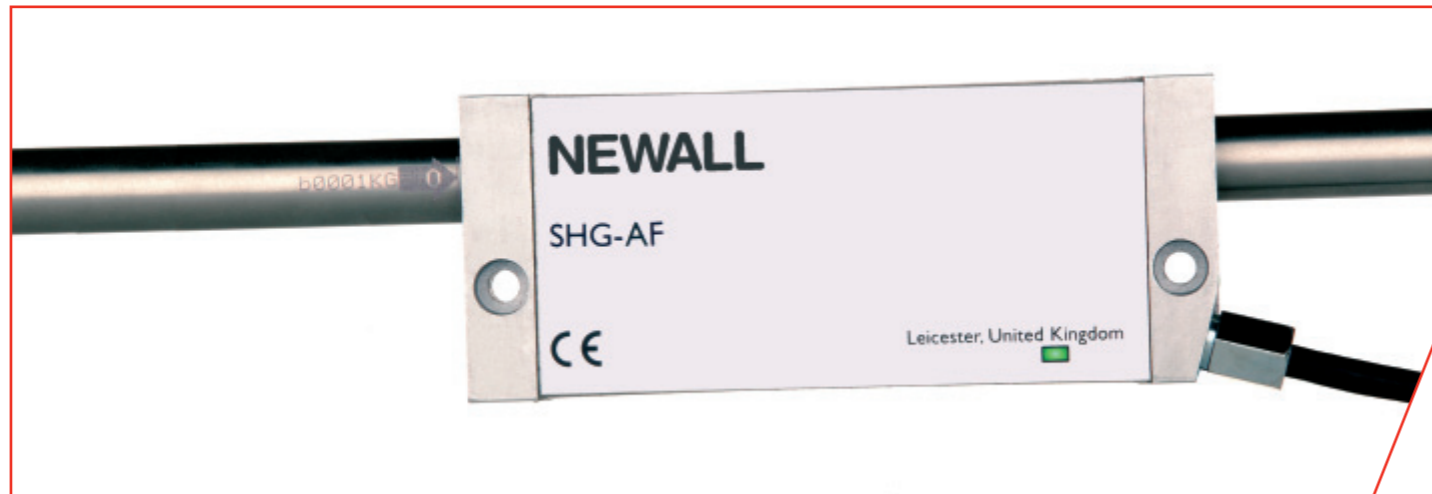

Product Absolute and Distance-Coded Linear Encoders

Specification	SHG-A2, SHG-A4, SHG-AB, SHG-AF, SHG-AG, SHG-AS, SHG-AV	SHG-TC	Options
Type	Inductive	Inductive	
Accuracy Grade	±10µm (0.0004in)	±5µm (0.0002in)	3 & 5µm (0.002in, 0.0002in)
Resolutions (µm/m)	1µm	1µm	0.5, 5, 10µm
Resolutions (in)	0.00005in	0.00005in	0.00002in, 0.0002in, 0.004in
Reference Type	None	Distance-Coded	
Reference Location	Every 10mm via RS422 interface Except SHG-AF & SHG-AV = None	Max 20mm movement (0.8in)	
Maximum Traverse Rate	SHG-A2 = 6m/s SHG-A4 = 6m/s SHG-AB = 6m/s SHG-AF = 4m/s SHG-AG = 6m/s SHG-AS = 6m/s SHG-AV = 4m/s limited by SCC200	4m/s at 1µm resolution	
Maximum Acc. / Dec.	10g / 980m/s (head moving)	10g / 980m/s (head moving)	
Power Supply	5VDC ± 5% <80mA	5VDC ± 5% <80mA	
Shock (11ms)	100g / 980m/s ² (IEC 69-2-6)	100g / 980m/s ² (IEC 69-2-6)	
Vibration (55-2000Hz)	30g / 294m/s ² (IEC 68-2-27)	30g / 294m/s ² (IEC 68-2-27)	
Ingress Protection (IP) Level	IP67, fully submersible (IEC 529) - Exceeds NEMA 6	IP67, fully submersible (IEC 529) - Exceeds NEMA 6	
Operating Temperature Range	0 to 55°C (32 to 131°F)	0 to 55°C (32 to 131°F)	
Storage Temperature Range	-20 to 70°C (-4 to 158°F)	-20 to 70°C (-4 to 158°F)	
Magnetic Field Susceptibility	3mT (30 Gauss)	3mT (30 Gauss)	
Radiated Magnetic Field	10mT (100 Gauss)	10mT (100 Gauss)	
Overall Cross-Section	53.5 x 28.5mm (2 x 1in)	53.5 x 28.5mm (2 x 1in)	
Scale Material	Stainless Steel	Stainless Steel	
Co-efficient of Expansion	12ppm/°C	12ppm/°C	
Scale OD	15.25mm (0.6in)	15.25mm (0.6in)	
Maximum Scale Travel	3500mm (138in)	3500mm (138in)	
Maximum Single End Mount Measuring Length	350mm (14in)	350mm (14in)	
Maximum Length between Supports*	1000mm (39in)	1000mm (39in)	
Scale Over-Travel Requirements	254mm (10in)	254mm (10in)	
Standard Cable	9 core screened cable with PUR (polyurethane) cover with no armour	9 core screened cable with PUR (polyurethane) cover with no armour	Fully interlocked stainless steel armour
Cable Length	0.5m (20in)	0.5m (20in)	
Minimum Bend Radius with PUR	25mm (1in)	25mm (1in)	With Armour 50.8mm (2in)
Maximum Cable Length	18m (708in)	18m (708in)	
Connector	D Type 15 Pin (IP54, NEMA 6)	D Type 15 Pin (IP54, NEMA 6)	19 Pin (IP67, NEMA 6)
EMC Compliance	BS EN 50081-2 & BS EN 50082-2	BS EN 50081-2 & BS EN 50082-2	

*Only applies for travels over 2540mm (100 in)

Product Linear Encoder with Flexible Mounting System
Suitable for press brake applications

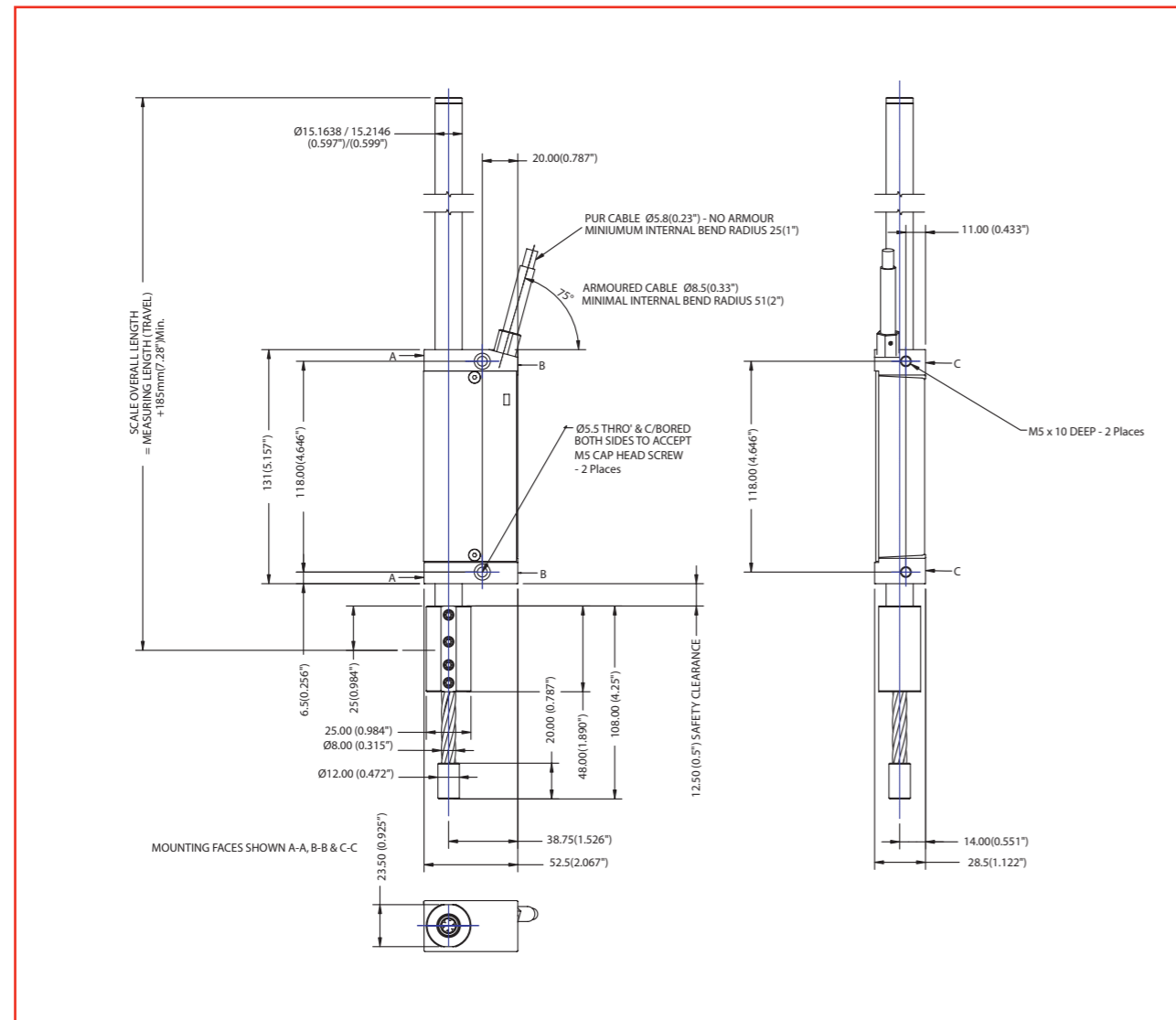

Product Linear Encoder with Flexible Mounting System
Suitable for press brake applications

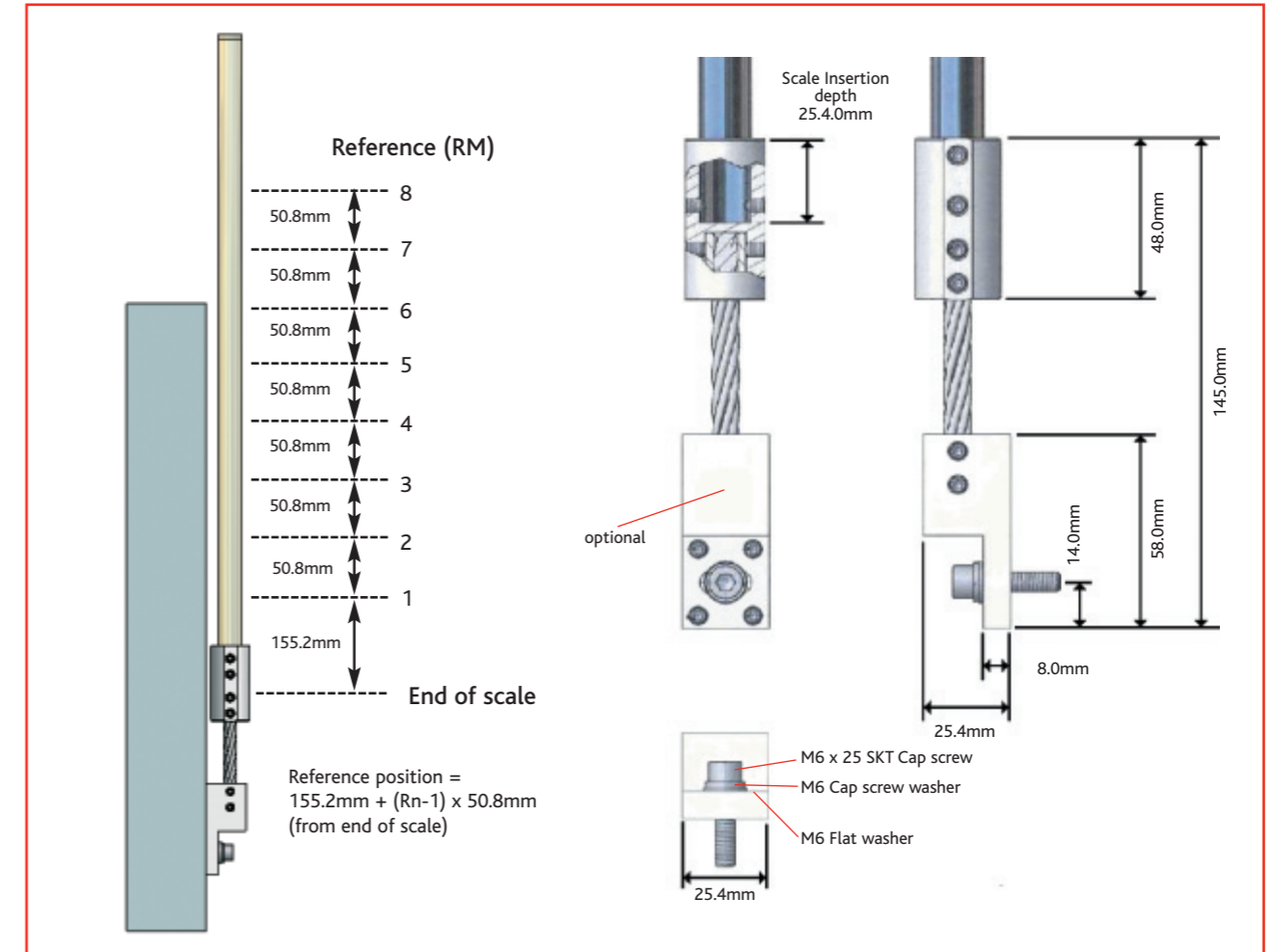

Specification	SPB-TS, SPB-TT
Type	Inductive
Accuracy Grade	±10µm (0.0004in)
Resolutions (µm/m)	1, 5, 10µm
Resolutions (in)	0.00005in, 0.0002in, 0.0004in
Maximum Traverse Rate	1m/s at 1µm resolution
Maximum Acc. / Dec.	10g / 100m/s
Power Supply	5VDC ± 5% <85mA
Reference Mark	SPB-TS = User selectable from 1-8 (50.8mm apart) SPB-TT = Periodic (12.7mm)
Shock (11ms)	100g / 980m/s ² (IEC 69-2-6)
Vibration (55-2000Hz)	30g / 294m/s ² (IEC 68-2-27)
Ingress Protection (IP) Level	IP67, fully submersible (IEC 529) - Exceeds NEMA 6
Moving Force	<5N
EMC Compliance	BS EN 50081-2 & BS EN 50082-2
Operating Temperature Range	0 to 55°C (32 to 131°F)
Storage Temperature Range	-20 to 70°C (-4 to 158°F)
Overall Length	Travel + 277.5mm (10.93in)
Mounting Alignment Tolerance	±3mm at opposite end to flexible mounting system

SCC200 High Performance Converter for servo applications



Incremental sinusoidal signals - 1Vpp (Vss)

The sinusoidal incremental signals are produced by advanced processing of both the A and B signal channels. These channels are phase shifted by 90° and have a signal level of 1Vpp differential when terminated using the recommended circuitry with a common mode voltage of 2.5V. The signal levels are maintained at all speed levels providing no loss of signal integrity with increasing scanning frequency.

Note: The SCC200 is designed for DIN rail mount. (European DIN rail standards: EN50022 & EN50035)

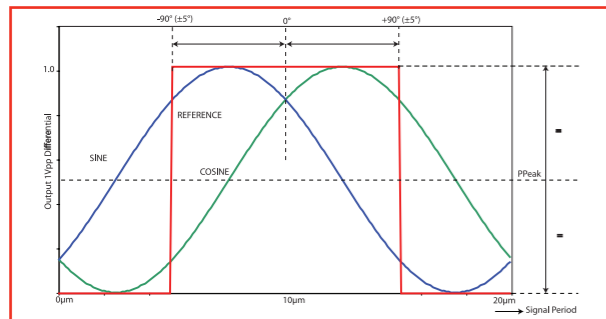

Recommended Input Circuitry at Terminating Electronics

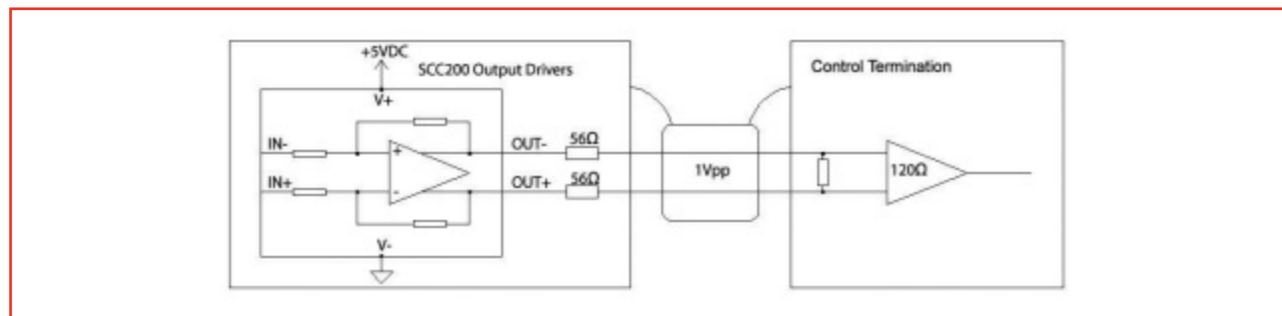

Input Power Connection

If the control cannot provide the required power, an external supply can be connected.

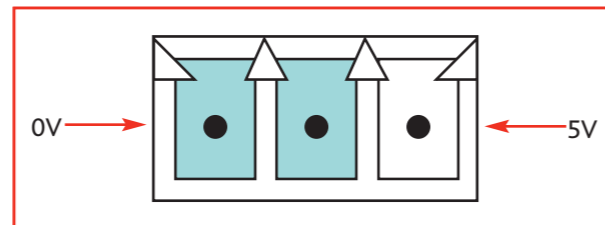

If the control can supply the required power, insert the link provided as shown below.

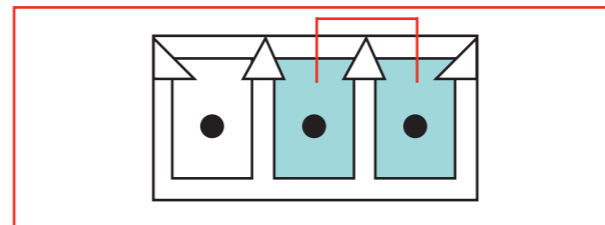

SCC200 High Performance Converter

Dimensions

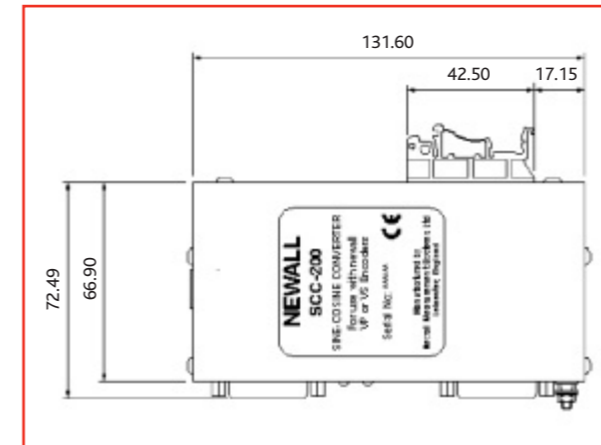

SCC200 Connections (Signal Out Connector 15 pin male D type)

Pin Number	VS, VP Function	AV Function
1	Reserved	SSI CLK +
2	Reserved	Reserved
3	Reserved	Reserved
4	RM-	Reserved
5	B-	B-
6	A-	A-
7	Reserved	Reserved
8	5V	5V
9	Reserved	SSI CLK +
10	Reserved	SSI DATA+
11	Reserved	SSI DATA+
12	RM	Reserved
13	B+	B+
14	A+	A+
15	0V	0V
Shell	Ground	Ground

Connections marked as reserved DO NOT CONNECT

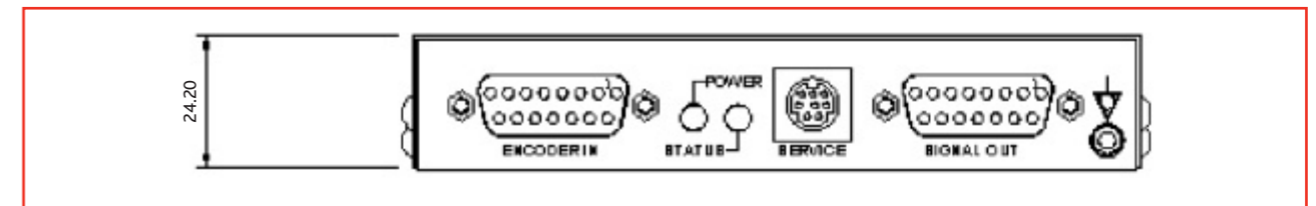

Specification

Power Supply	5VDC ±5% <300mA
Operating Temperature	0° to 55°C
Storage Temperature	-20° to 70°C
Ingress Protection Level	IP54
EMC Compliance	BS EN 50081-2 BS EN 50082-2
Sinusoidal Voltage Output Signal	~ 1Vpp differential
Sinusoidal Signals A & B* Signal Levels	0.8 to 1.2Vpp*, typically 1Vpp
Amplitude Ratio (A to B)	0.95 to 1.05
Phase Angle	90° ± 5° elec
Ref. Mark Zero Crossover Point	± 90° ± 5° elec
Dimensions	131mm x 67mm x 24mm**
Weight	0.5lbs (0.23kg)**
Part Number (for encoder):	SHG-VP SHG-VS SHG-AV 600-82875 MHG-VP MCG-VP 600-82870

* With recommended input circuitry at terminating electronics

** Dimensions and weight do not include optional link or DIN rail mount

Connectors & Cables

Standard Connectors (IP54, NEMA 3) 9 Pin D Connector

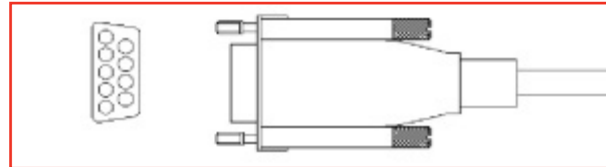

Colour	Pin	Function
Orange	1	Reserved, Do Not Connect
Green	2	Channel A
Yellow	3	Channel \bar{A}
Blue	4	Channel B
Red	5	Channel \bar{B}
White	6	0V
Black	7	5V
Violet	8	Channel RM
Grey	9	Channel $\bar{R}M$
Screen	SHELL	GND

15 Pin D Connector

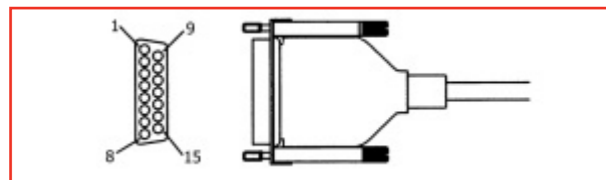

Colour	Pin	Function
Light Green	1	Fanuc RQ / SSI CLK
Orange	2	Reserved, Do Not Connect
Pink & White	3	RS232 TX
Grey	4	$\bar{R}M$
Red	5	\bar{B}
Yellow	6	\bar{A}
Pink	7	RS232 RX
Black	8	+5VDC
Light Green & White	9	Fanuc RQ/SSI CLK
Brown	10	Fanuc Data / SSI Data / RS485
Brown & White	11	Fanuc Data / SSI Data / RS485
Violet	12	RM
Blue	13	B
Dark Green	14	A
White	15	0V
Screen	SHELL	GND

Optional Connector (IP67, NEMA 6) 12 Pin Connector

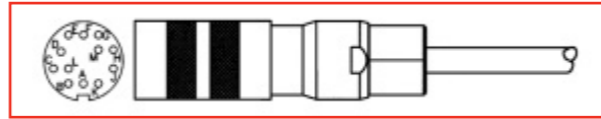

Colour	Pin	Function
Orange	A	Reserved, Do Not Connect
White	B	0V
White	C	0V
Yellow	D	Channel \bar{A}
Green	E	Channel A
Red	F	Channel \bar{B}
Blue	G	Channel B
Violet	H	Channel RM
Black	J	5V
Black	K	5V
	L	
Grey	M	Channel $\bar{R}M$
Screen	SHELL	GND

Optional Connector (IP67, NEMA 6) 19 Pin Connector

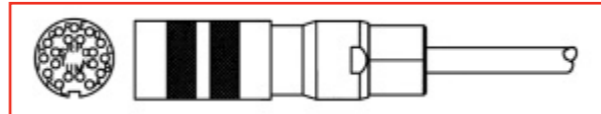

Colour	Pin	Function
Pink & White	A	RS232 TX
Black	B	+ 5VDC
Black	C	+ 5VDC
Black	D	+ 5VDC
Grey	E	RM
Violet	F	RM
Orange	G	Reserved, Do Not Connect
White	I	0V
White	K	0V
Pink	L	RS232 RX
Light Green & White	M	Fanuc RQ / SSI CLK
Brown	N	Fanuc Data / SSI Data / RS485
Brown & White	O	Fanuc Data / SSI Data / RS485
Red	P	B
Yellow	S	A
Dark Green	T	A
Light Green	U	Fanuc RQ / SSI CLK
Screen	SHELL	GND

Extension Cables

There are a selection of extension cables available for the range of encoders. Therefore a cable selection guide has been devised to ensure you can purchase the product you require.

Select one option per section as required. The options in turn make up the part number.

Section	Option	Option Description
Section 1		
Extension Cable Digital	ELD	Prefix applicable for all digital extension cables
Section 2		
Connector reader head end	09D0	9 pin D (IP54, NEMA 3)
	15D0	15 pin D (IP54, NEMA 3)
	09B0	12 pin round (IP67, NEMA 6)
	15B0	19 pin round
Section 3		
Cable Length	035	3.5m cable
	050	5m cable
	070	7m cable
	100	10m cable
Section 4		
Termination output end	0D	9 pin D (IP54, NEMA 3)
	1D	15 pin D (IP54, NEMA 3)
	FL	Flying leads (tails)
	FA	Fanuc (Honda)
	AM	Amp
Section 5		
Armour	0	Armoured
	1	Non-armoured

Extension cable for SCC200 to CNC/PLC/Motion Control/Drive Encoder Interface

Select one option per section as required. The options in turn make up the part number.

Section	Option	Option Description
Section 1		
Extension Cable Digital	ELD	Prefix applicable for all digital extension cables
Section 2		
Connector SCC200 output	15DS	15 pin D (IP54, NEMA 3)
Section 3		
Cable length	005	0.5m cable
	010	1m cable
	015	1.5m cable
	035	3.5m cable
Section 4		
Termination output end*	2D	15 pin D (IP54, NEMA 3), Siemens 611D Drive or 840D CNC
	FL	Flying leads (tails)
Section 5		
Armour	0	Armoured
	1	Non-armoured

* Other termination outputs available on request

General Information

The Spherosyn™ Technology Advantage

Environmental Protection

All variants of Newall encoders carry an Ingress Protection (IP) rating of 67 (NEMA 6). The encoders are fully submersible and will continue to provide accurate and dependable readings under the harshest conditions. Unlike most glass based systems, no air purging is required. Dirt, swarf, cast iron dust, graphite dust and other common contaminants will not effect the performance of the system.

Shock and Vibration

In comparison to other linear displacement technologies, Newall's Linear Encoders are tolerant to high degrees of vibration and shock.

- Shock and Impact (11ms IEC 69-2-6):
Spherosyn™ technology = 1000m/s² (100g)
- Vibration (55 - 2000Hz IEC 68-2-27):
Spherosyn™ technology = 300m/s² (30g)

Reliability

Newall encoders require no regular cleaning or maintenance. Unlike optical/glass-based systems, Newall encoders have no general wear characteristics. There are no LEDs to burn out or glass to get scratched or broken. There are no roller bearings, leaf springs or other moving parts to wear out or fail.

Ease of Installation

Installation can be accomplished in a fraction of the time as compared to other linear systems. Even with scale lengths up to 12 metres, machined surfaces or backing bars are not needed. For more compact installations, single end mounting options exist, where the scale need only be supported on one end. These are designed for direct integration into OEM design or optional Newall mounting brackets can be selected.

Accuracy, Repeatability and Resolution

The laser measurement system used to calibrate all of Newall scales have been calibrated by accredited laboratories providing traceability to UK national standards. The procedures comply with the requirements of British Standard Specification BS5781/International Standard ISO10012-1. The National Physical Laboratory (NPL) calibrates the master standard, certificate number 08A014/9501. All Newall Calibration rigs are traceable back to this NPL standard. The calibration of the Newall scales and reader heads is conducted in a temperature controlled (21°C) environment.

Thermal Expansion

The thermal behaviour of the linear encoder is an essential criterion for the working accuracy of a machine tool. And thus it is common knowledge that the thermal behaviour of the encoder should match that of the workpiece.

Consequently, a 10°C temperature rise can result in a thermal expansion error for glass in the order of 40µm over 1m of travel. In practice, it is rare that thermal stability will be achieved within the machine, workpiece or encoder during normal operation due to rates of thermal behaviour and environmental conditions. As a result, errors due to thermal effects are impossible to quantify and may be greater or lower than those theoretically calculated. Such errors are minimised by ensuring that the encoder is as matched as possible to both the machine and workpiece.

Product Group	PPM	Steel/Iron (12ppm)	Differential
Glass	8	12	4
Aluminium	23	12	-11
Spherosyn™*	12	12	0

* Spherosyn™ results measured by the Department of Physics University of Hull using strain gauge dilometry with temperature compensation

Newall reserves to change specifications to the products without notification and the company accept no liability for claims from any changes.

© 2007 - All proprietary rights, including design rights, copyright and trademarks, in the content materials, information, data, images, graphics, typographical arrangements and photographs appearing in this brochure are and shall remain the property of Newall Measurement Systems Limited. No portion of this brochure or any of its content may be reproduced, duplicated, copied, distributed or otherwise utilised for any purpose without our express written consent.



NEWALL

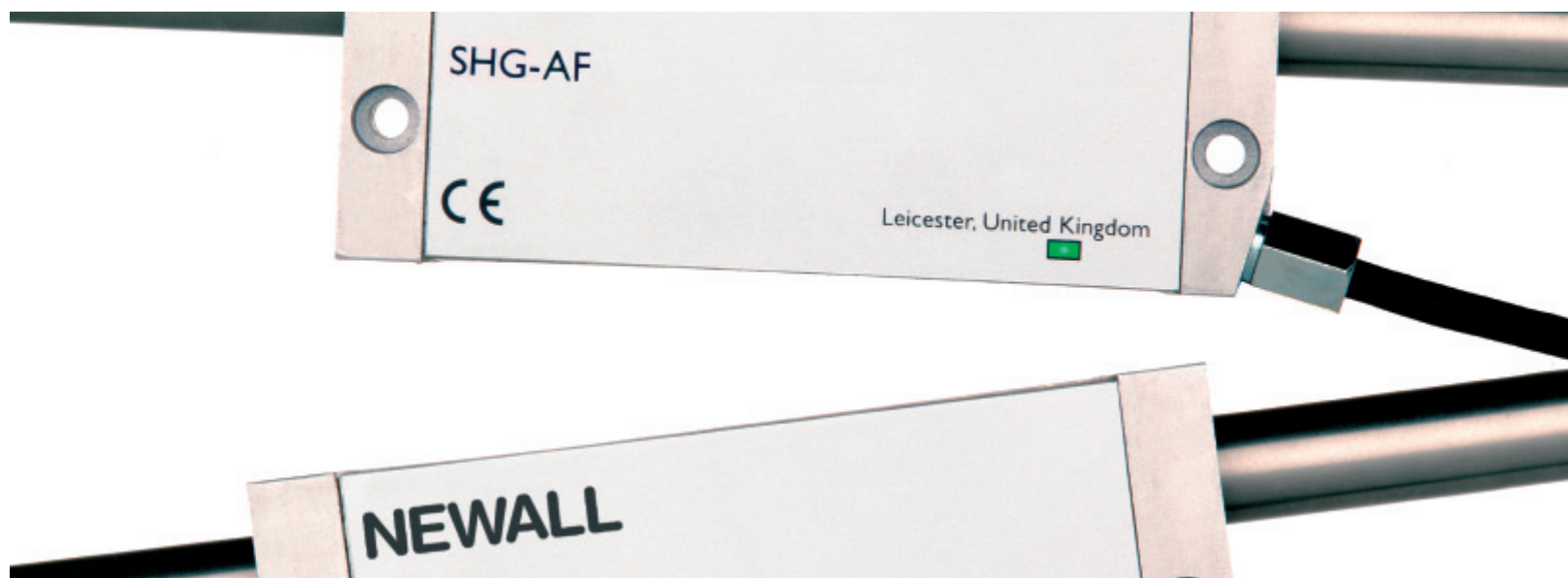

Linear Encoders