

# Model SSG

## Digital Pressure Gauge / Switch

### Description

SSG model contains Microprocessor in default. Moreover, it is a Pressure Gauge / Switch with characteristics of LED Display, 1~5VDC or 4~20mA(3wire) Analog Output, 2-Channel RELAY Output. Since it uses IP65 structure, there is no limitation with environmental conditions. As Pressure Sensor, Indicator and Switch are integrated in order to realize providing it at low price

### Features

- ▶ CE Certified
- ▶ IP65 Protection
- ▶ LED display(Height 10mm)
- ▶ Built-in amplifier circuit(1~5VDC, 4~20mA)
- ▶ Optional 2-channel Relay switching output
- ▶ Measuring range -0.1~500MPa
- ▶ 0.5~0.8%FS accuracy
- ▶ 18~26VDC excitation voltage

### Applications

- ▶ Process control
- ▶ Hydraulics & Pneumatic
- ▶ Compressor Control
- ▶ Chillers
- ▶ Refrigeration Equipment

### Specifications



#### SSGA / □

#### SSGB / □

Range	SSGA / □		SSGB / □	
	0~5kPa ... 3.5MPa(Gauge)	0~3.6 ... 500MPa(Gauge)	0~5kPa ... 70MPa(Gauge)	0~71 ... 500MPa(Gauge)
	-100kPa~0 ... 3.5MPa(Gauge)		-100kPa~0 ... 70MPa(Gauge)	
	0~35kPa ... 70MPa(Absolute)		0~35kPa ... 70MPa(Absolute)	
<b>Performance</b>				
Accuracy	±0.5%FS ± 1digit	±0.8%FS ± 1digit	±0.5%FS ± 1digit	±0.8%FS ± 1digit
Thermal Effect on Zero	±0.05%FS/°C	±0.08%FS/°C	±0.05%FS/°C	±0.08%FS/°C
Thermal Effect on Span	±0.05%FS/°C	±0.08%FS/°C	±0.05%FS/°C	±0.08%FS/°C
Compensated Temperature Range		-10 ~ 70°C		
Operating Temperature Range		-20 ~ 80°C		
<b>Electrical</b>				
Display			LED(Red Color)	
Max Readout			±1999(3 1/2)	
Height of Digits			10mm	
Excitation			18 ~ 26VDC	
Output				
Switching Signal		-	2Ch. Relay (5A 28VDC / 10A 125VAC / 5A 250VAC)	
Analog Signal			1~5VDC, 4~20mA(3Wire)	
Electrical Connection		Cable		DIN Connector
<b>Physical</b>				
Proof Pressure	≤ 150 MPa : X1.5 or 150MPa Whichever is less. / > 150MPa : X1.5 or 500MPa Whichever is less.			
Burst Pressure	≤ 150 MPa : X2 or 150MPa Whichever is less. / > 150MPa : X2 or 600MPa Whichever is less.			
Vibration	49.1m/s <sup>2</sup> {5G}, 10~500Hz			
Shock	490m/s <sup>2</sup> {50G}			
Pressure Port	R(PT)3/8", 9/16UNF Female(Only > 1500bar), Other Connection Available on Request			
Media-Wetted Materials	Stainless Steel, VITON	Stainless Steel, Ti 87%	Stainless Steel, VITON	Stainless Steel, Ti 87%
Protection	IP65			
Weight	Approx. 700g (Standard type only)			

## Dimension

### ▶ SSGA/SSGC(Standard Type)

#### ● Stand Type

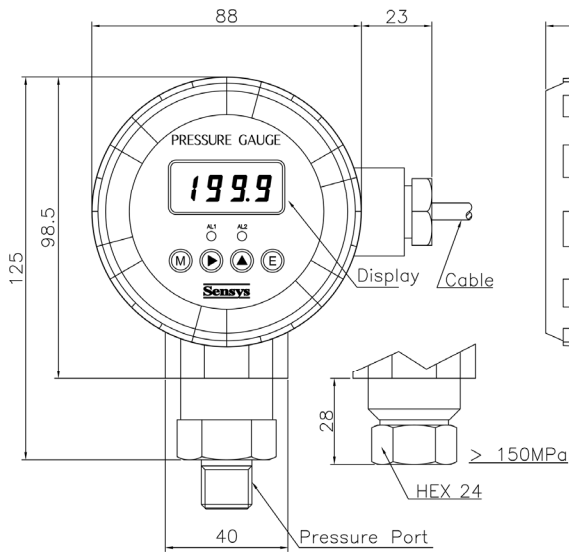

Wire Color	Connections
Red	Input ⊕
White	Common ⊖
Green	Output ⊕
Shield	Earth

#### ● Panel Mounting Type

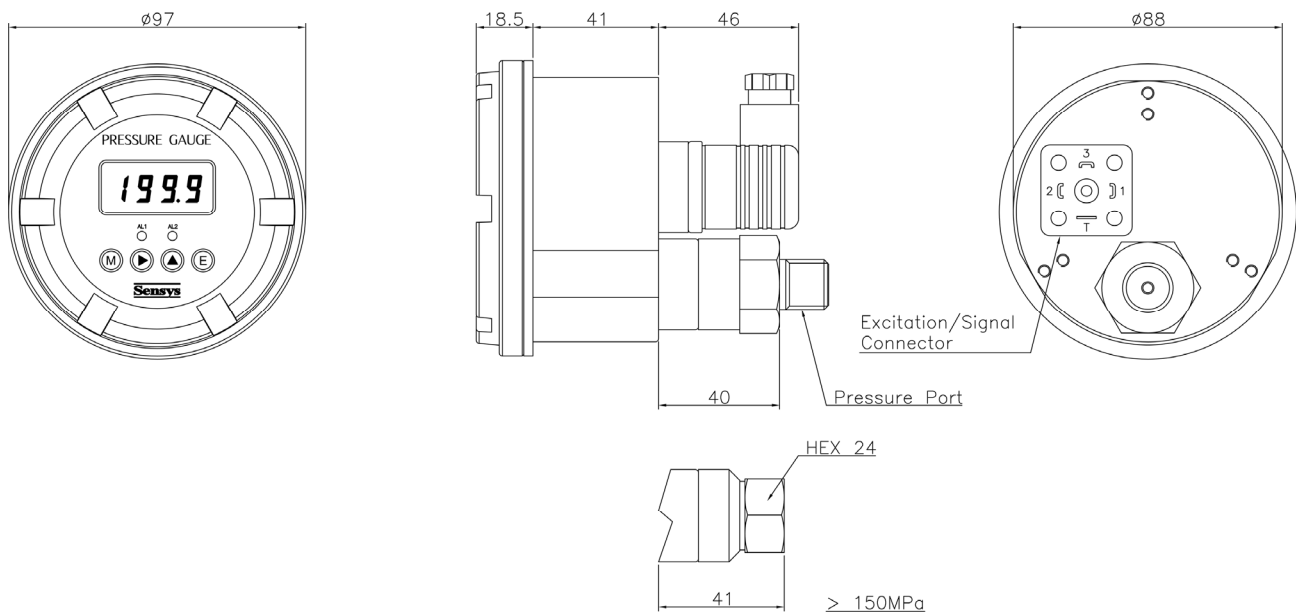

Excitation/Signal Pin No.	Connections
1	Input ⊕
2	Common ⊖
3	Output ⊕
⊖	Earth

► SSGB(Switch Output Type)

● Stand Type

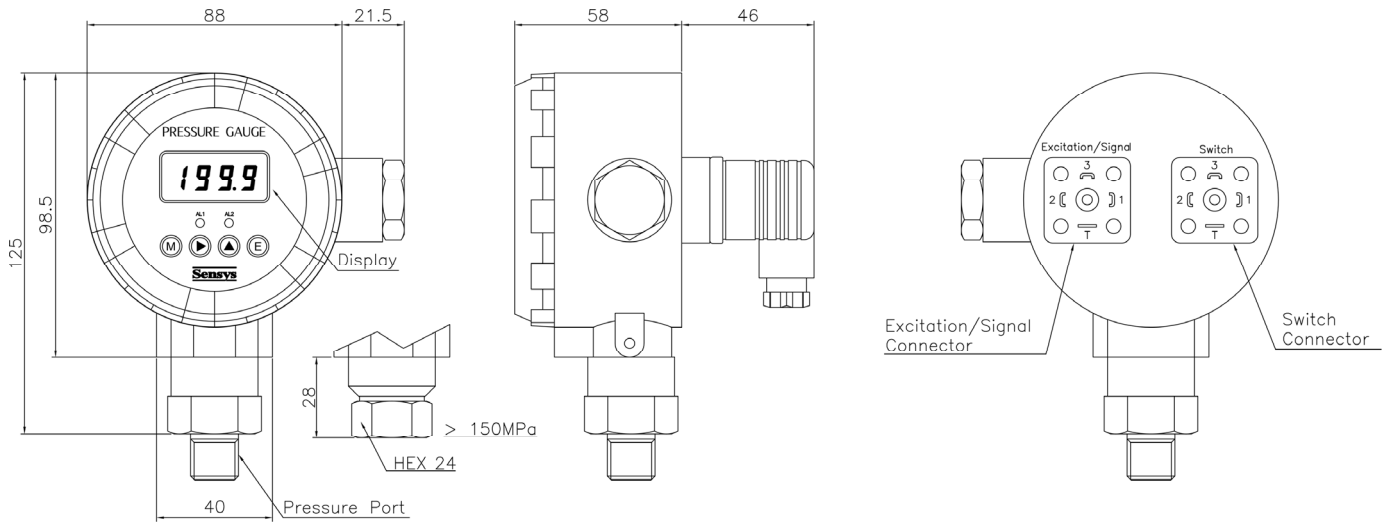

Excitation/Signal Pin No.	Connections	Switch Pin No.	Connections
1	Input⊕	1	Switch 1
2	Common⊖	2	Switch 1
3	Output ⊕	3	Switch 2
⊖	Earth	⊖	Switch 2

● Panel Mounting Type

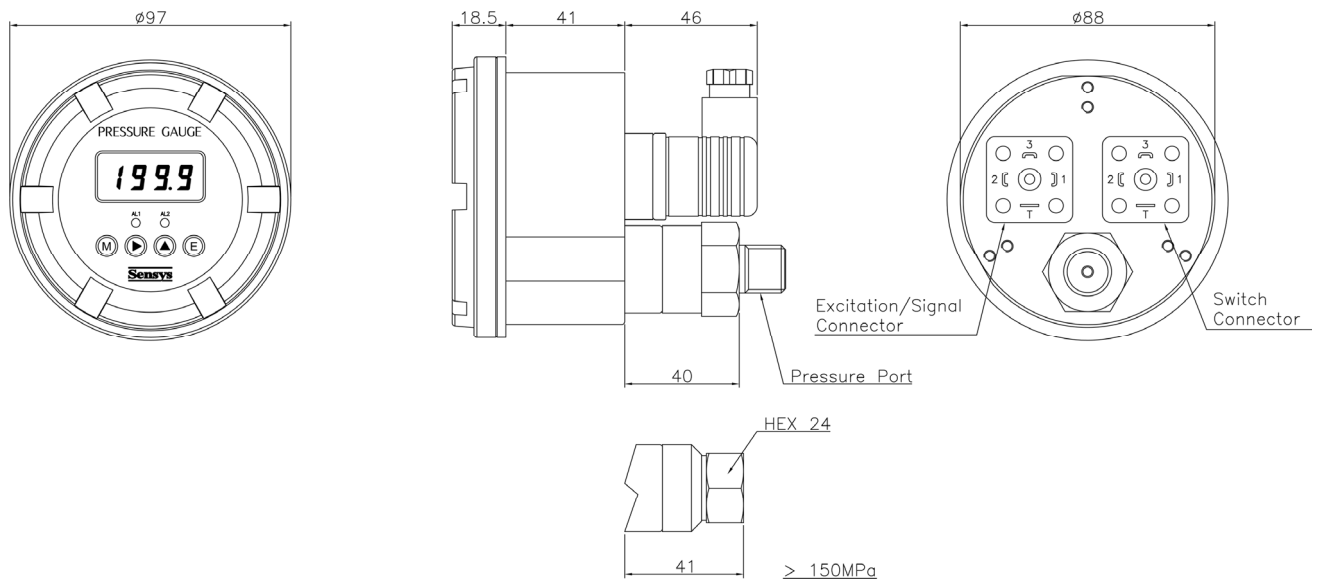

Excitation/Signal Pin No.	Connections	Switch Pin No.	Connections
1	Input⊕	1	Switch 1
2	Common⊖	2	Switch 1
3	Output ⊕	3	Switch 2
⊖	Earth	⊖	Switch 2

► Pressure Port(> 1500bar)

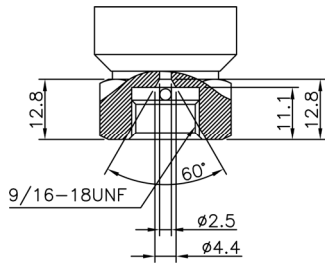

**Alarm Mode**

► Hi Mode

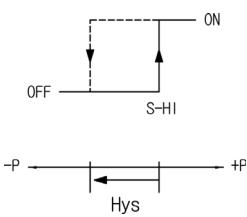

► Low Mode

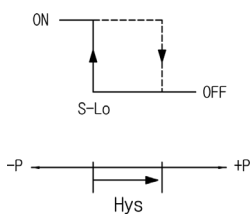

► A Mode

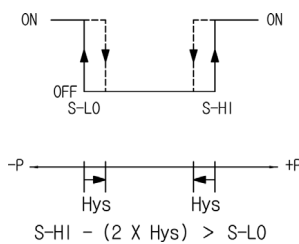

► B Mode

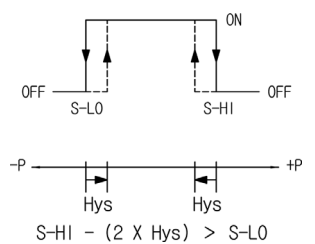

**Ordering Information**

**SSG A 01.00 M A A G**

**Model Name**

**Output**

- A : 1~5V
- B : 2-Ch. Relay, 1~5V
- C : 4~20mA(3Wire)
- D : 2-Ch. Relay, 4~20mA(3Wire)

**Pressure Range(Display Digit)**

- XXXX : Pressure
- CXXX : Compound Pressure

**Pressure Unit**

- R : kPa                      M : MPa
- B : bar                        K : kgf/cm<sup>2</sup>
- P : psi                        H : mmHg
- C : cmH<sub>2</sub>O

**Type of Pressure Measurement**

- G : Gauge
- J : Absolute

**Type**

- A : Stand Type
- B : Panel Mounting Type

**Pressure port**

- A : R(PT)3/8"                D : G(PF)1/4"
- B : G(PF)3/8"                E : R(PT)1/2"
- C : R(PT)1/4"                Q : G(PF)1/2"
- K : 9/16-18 UNF(F) (Only > 1500bar)