



## Design and applications

Wherever a robust and reliable device for the indication of momentary values and the monitoring of flows in pipelines is required in plant engineering, the flap-type flow meter is the right choice as a reliable device for the measurement of liquids.

The meters from the KLA product range are based on the same principle. Inside the meter a flap moves up and down in analogy to the amount of liquid flowing through.

In the standard KLA version a magnet directly transfers the flap movement to an externally mounted pointer that indicates the flow quantity on a powder coated aluminium disk.

In the KLA-GS version the quantity is directly indicated by the flap. The flap-type flow meter is equipped with hard glass screens at the front and the back. The flow rate is taken from a scale engraved into the front hard glass screen.

Beside this indication of the flow rate, the low-cost variant of the meter also provides a direct visual display.

For process control, the measuring device can be equipped with limit value switches or an analogue output.

KLA



- **robust device for a vertical and a horizontal installation**
- **suitable for measuring flows of e.g. H<sub>2</sub>O, oil or suspensions**
- **wide measuring range per nominal width**
- **low pressure loss**
- **designed for easy maintenance**
- **largely viscosity independent**
- **wide choice of material**
- **optionally**
  - **limit value switches**
  - **analogue output 4 ... 20 mA**
  - **explosion-proof design**
  - **NR-lining for acids and alkaline solutions**





## Type series

KLA	with magnetically coupled pointer dial
KLA-GS	with glass screen
KLA-IK	with one inductive switch
KLA-IKS	with one electronic switch
KLA-EM	angular position encoder with 4 ... 20 mA analogue output
KLA-V4A	↳ made of stainless steel (1.4571)
KLA Ex	explosion proof design
KLA-IK Ex	↳ with one inductive switch

## Technical data

Connection	Flange connection acc EN 1092-1 PN10 optionally: ANSI B16.5 150 lbs
Pressure ranges	PN 10 (standard) in special design PN 6
Connection sizes	DN 15 – 200 / 1" – 8"
Installation length	see table p. 3
Corrosion protection	Epoxy powder coating, traffic blue (RAL 5017) glossy
Corrosion class	C3
Rubber lining	NR-isoprene quality
Temperature resistance <sup>1)</sup>	standard max. 100 °C with rubber lining max. 90 °C special design up to 150 °C
Ambient temperature	max. 90 °C
Measuring range	usu. 1:10
Uncertainty of measurement	5 % FS
Degree of protection	following IP 54, switch IP 53

<sup>1)</sup> The medium to be measured must not freeze.  
other connection geometries on request

## Materials

Type/Fitting	flap	bearing	disc	blind flange/ring	seal	DN
<b>KLA</b>						
Gray cast iron EN-GJL-200	1.4571	1.4571	1.4571	EN-GJL-200 / S355	NBR	15 – 150
Steel S355, welded	1.4571	1.4571	1.4571	S355	NBR	200
<b>KLA-V4A</b>						
Stainless steel 1.4571, welded	1.4571	1.4571	1.4571	1.4571	FKM	25 – 100
<b>KLA-GS</b>						
Gray cast iron EN-GJL-200	1.4571	1.4571	Soda lime glass <sup>1)</sup>	S355	NBR	15 – 150
<b>KLA-GS-V4A</b>						
Stainless steel 1.4571, welded	1.4571	1.4571	Borosilicate glass	1.4571	FKM	25 – 100
<b>KLA rubber lined design</b>						
Gray cast iron EN-GJL-200 rubber lined	1.4571	1.4571	1.4571	EN-GJL-200 / S355 rubber lined	Sil-C8200	32 – 150
Gray cast iron EN-GJL-200 rubber lined	Hastelloy C4	Hastelloy C4	1.4571 – PTFE	EN-GJL-200 / S355 rubber lined	Sil-C8200	32 – 150
Gray cast iron EN-GJL-200 rubber lined	PTFE	Hastelloy C4	1.4571 – PTFE	EN-GJL-200 / S355 rubber lined	Sil-C8200	80 – 150
Gray cast iron EN-GJL-200 rubber lined	PTFE	PTFE	1.4571 – PTFE	EN-GJL-200 / S355 rubber lined	Sil-C8200	80 – 150

We quote other designs on request:

- gaskets, rubber lining (also with the approval for drinking water)
- cast bronze (CuSn)

<sup>1)</sup> optionally: borosilicate glass

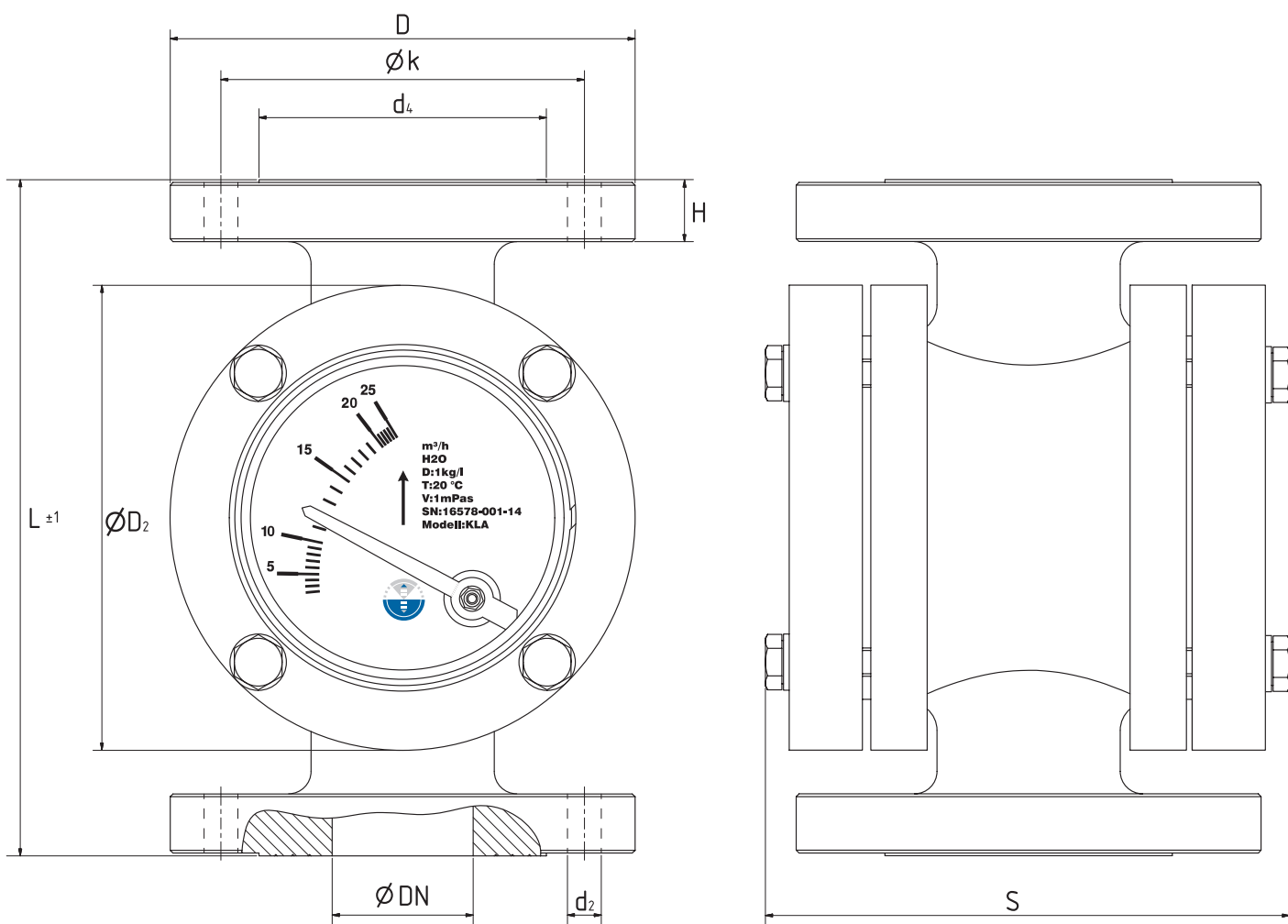

## Dimensions and weights Connection acc. DIN EN 1092-1 PN10

DN	Dimensions							number of screws	S			weight [kg]
	Ø D	Ø k	Ø d <sub>4</sub>	Ø H	L	Ø D <sub>2</sub>	d <sub>2</sub>		standard/IK	GS	EM	
15	95	65	45	18	170	119	M12	4	145	132	166	8
20	105	75	58	18	170	119	M12	4	145	132	166	8,5
25	115	85	68	18	170	119	Ø 14	4	145	132	166	9
32	140	100	78	21	240	165	Ø 18	4	176	186	197	16
40	150	110	88	21	240	165	Ø 18	4	176	186	197	16
50	165	125	102	21	240	165	Ø 18	4	176	186	197	17
65	185	145	122	21	280	185	Ø 18	4	201	217	222	22
80	200	160	138	22	320	225	Ø 18	8	214	227	235	34
100	220	180	158	24	350	245	Ø 18	8	267	278	288	43
125	250	210	188	25	380	285	Ø 18	8	299	310	320	58
150	285	240	212	25	380	295	Ø 22	8	299	310	320	64
200	340	295	268	27	550	370	Ø 22	8	386	-	407	104

all dimensions in mm



**KLA**

Flap-type flow meters

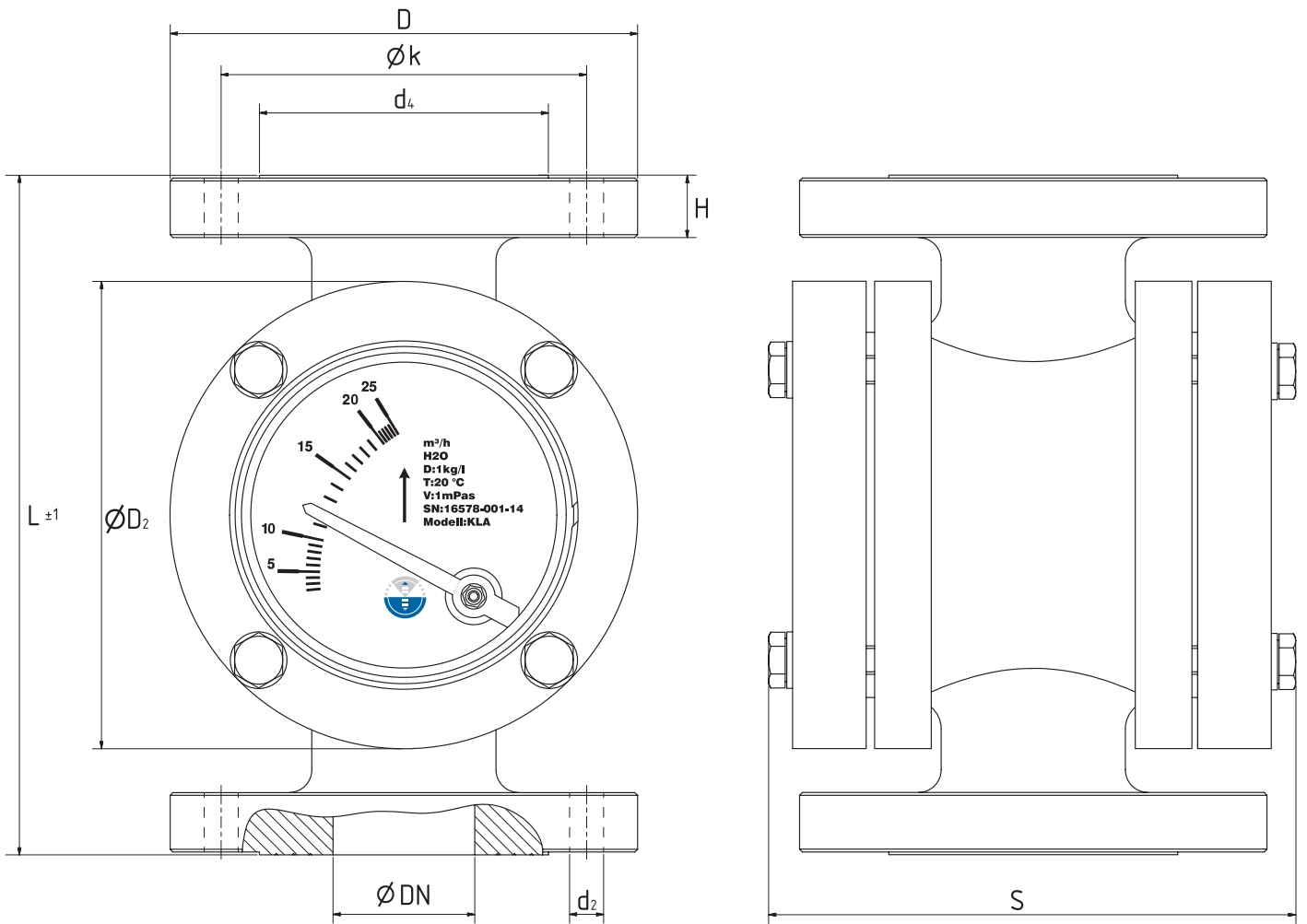

**Dimensions and weights**  
**Connection acc. ASME B16.5 Class 150**

ASME B16.5 NPS	Dimensions								number of screws	S			weight [kg]
Ø DN	Ø D	Ø k	Ø d₄	Ø H	L	Ø D₂	d₂	standard/ IK		GS	EM		
1/2"	15	90	60,3	34,9	18	170	119	1/2" *	4	145	132	166	8
3/4"	20	100	69,9	42,9	18	170	119	Ø 15,9	4	145	132	166	8,5
1"	25	110	79,4	50,8	18	170	119	Ø 15,9	4	145	132	166	9
1 1/4"	32	115	88,9	63,5	21	240	165	Ø 15,9	4	176	186	197	16
1 1/2"	40	125	98,4	73,0	21	240	165	Ø 15,9	4	176	186	197	16
2"	50	150	120,7	92,1	21	240	165	Ø 19,1	4	176	186	197	17
2 1/2"	65	180	139,7	104,8	21	280	185	Ø 19,1	4	201	217	222	22
3"	80	190	152,4	127,0	22	320	225	Ø 19,1	4	214	227	235	34
4"	100	230	190,5	157,2	24	350	245	Ø 19,1	8	267	278	288	43
5"	125	255	215,9	185,7	25	380	285	Ø 22,2	8	299	310	320	58
6"	150	280	241,3	215,9	25	380	295	Ø 22,2	8	299	310	320	64
8"	200	345	298,5	269,9	27	550	370	Ø 22,2	8	386	-	407	104

alle Maße in mm

\* Thread according to customer specification (UNC, UNF, G etc.)

## Measuring ranges

DN	measuring range H <sub>2</sub> O horizontal flow				measuring range H <sub>2</sub> O vertical flow				max. operating pressure [bar] standard version	max. operating pressure [bar] device with glass screen
15	0,1	–	1	m <sup>3</sup> /h	0,2	–	1,5	m <sup>3</sup> /h	10	10
	0,5	–	6	m <sup>3</sup> /h	1	–	6,5	m <sup>3</sup> /h		
20	0,1	–	1	m <sup>3</sup> /h	0,2	–	1,5	m <sup>3</sup> /h	10	10
	0,5	–	6	m <sup>3</sup> /h	1	–	6,5	m <sup>3</sup> /h		
25	0,1	–	1	m <sup>3</sup> /h	0,2	–	1,5	m <sup>3</sup> /h	10	10
	0,5	–	6	m <sup>3</sup> /h	1	–	6,5	m <sup>3</sup> /h		
32	0,5	–	4	m <sup>3</sup> /h	0,5	–	4	m <sup>3</sup> /h	10	9
	2,5	–	30	m <sup>3</sup> /h	2,5	–	25	m <sup>3</sup> /h		
40	0,5	–	4	m <sup>3</sup> /h	0,5	–	4	m <sup>3</sup> /h	10	9
	2,5	–	30	m <sup>3</sup> /h	2,5	–	25	m <sup>3</sup> /h		
50	0,5	–	4	m <sup>3</sup> /h	0,5	–	4	m <sup>3</sup> /h	10	9
	2,5	–	30	m <sup>3</sup> /h	2,5	–	25	m <sup>3</sup> /h		
65	1	–	8	m <sup>3</sup> /h	2	–	15	m <sup>3</sup> /h	10	10
	2,5	–	50	m <sup>3</sup> /h	5	–	50	m <sup>3</sup> /h		
80	1	–	10	m <sup>3</sup> /h	2	–	10	m <sup>3</sup> /h	10	10
	5	–	70	m <sup>3</sup> /h	5	–	50	m <sup>3</sup> /h		
100	1,5	–	15	m <sup>3</sup> /h	2	–	15	m <sup>3</sup> /h	10	10
	10	–	120	m <sup>3</sup> /h	10	–	100	m <sup>3</sup> /h		
125	1	–	20	m <sup>3</sup> /h	2	–	20	m <sup>3</sup> /h	10	7
	20	–	180	m <sup>3</sup> /h	10	–	120	m <sup>3</sup> /h		
150	2	–	25	m <sup>3</sup> /h	4	–	25	m <sup>3</sup> /h	10	6,5
	10	–	200	m <sup>3</sup> /h	10	–	140	m <sup>3</sup> /h		
200	5	–	80	m <sup>3</sup> /h	20	–	150	m <sup>3</sup> /h	10	---
	30	–	300	m <sup>3</sup> /h	20	–	200	m <sup>3</sup> /h		

The table shows the minimum and maximum measuring range, all intermediate measuring ranges available on request.  
Pressure loss 20 - 30 mbar depending on the flow-rate.



**KLA**

Flap-type flow meters

## Limit value switches

In order to realise a local display with a monitoring function the flowmeter can be equipped with limit value switches.

IK            2-wire-technology (Namur)  
 IKS          3-wire-technology (no Ex)

IK	2-wire (BI1-HS540-Y1)
Features	adjustable, bistable
Switching function	Normally closed, normally open
Output function	Two-wire, NAMUR
Voltage: NAMUR / other applications	max. 8.2 V DC / 8 ... 20 V DC
Power consumption: Pointer flag not captured	≥ 2.1 mA
Pointer flag captured	≤ 1.2 mA
Repeatability	≤ 2 % f.s.
Temperature drift	≤ ± 10 %
Hysteresis	1 ... 10 %
Temperature stability	-25 ... +70 °C
Approval according to	KEMA 02 ATEX 1090X
Identification of the sensor	Ex II 2 G Ex ia IIC T6 Gb / II 1 D Ex ia IIC T95 °C Da
Sil according to IEC 61508	SIL 3 and PL
Degree of protection	IP 67
MTTF	6198 years according to SN 29500 (Ed. 99) 40 °C
Electrical connection	cord
Cable quality	Ø 3 mm, blue, Lif9YYW, PVC, 2 m
Cable cross-section	2 x 0.14 mm <sup>2</sup>
Connection	

IKS	3-wire (BI1-HS540-AP6X)
Features	adjustable, bistable
Switching function	Normally closed, normally open
Output function	Three-wire, PNP
Operating voltage	10 ... 30 V DC
Repeatability	≤ 2 % f.s.
Temperature drift	≤ ± 10 %
Hysteresis	3 ... 15 %
DC Rated operational current	≤ 100 mA
No-load current	≤ 15 mA
Residual current	≤ 0.1 mA
Temperature stability	-25 ... +70 °C
Degree of protection	IP 67
MTTF	2283 years according to SN 29500 (Ed. 99) 40 °C
Electrical connection	cord
Cable quality	Ø 3 mm, grey, Lif9Y-11Y, PUR, 2 m
Cable cross-section	3 x 0,14 mm <sup>2</sup>
Connection	

## Analogue output 4 ... 20 mA

The angular position encoder EM is a 3-wire sensor, which delivers an output signal (4 ... 20 mA) proportional to the angular position of the pointer. This signal can be used to realize a remote display. A linearization is possible at up to 14 points.

Functional principle:

The direction of the magnetic field of a rotatable mounted magnet, which is moved by a fork, is detected by a contactless sensor, processed by a digital processor and converted to an output signal of 4 ... 20 mA.

EM	3-wire (4 ... 20 mA)
Accuracy	± 1 %
Temperature drift	< 50 ppm/ °C
Temperature resistance	-20 ... +70 °C
Operating voltage (U <sub>b</sub> )	12 ... 36 V DC
Load impedance	300 Ω at U <sub>b</sub> = 24 V 50 Ω at U <sub>b</sub> = 12 V
Power consumption	< 0,2 W, load-free output
Output function	Three-wire, analogue output
Current output	4 ... 20 mA
Measuring cycle	250 ms
Lifetime	> 10 <sup>6</sup> cycles
Protection class	IP64
Connection	

## Installation

When installing, the connecting flanges of the KLA must be fitted with appropriate gaskets. These gaskets are not included in the scope of delivery.

Flaps and valves may be installed before and behind the meter at a distance of at least 3 times the diameter.

## Flow directions

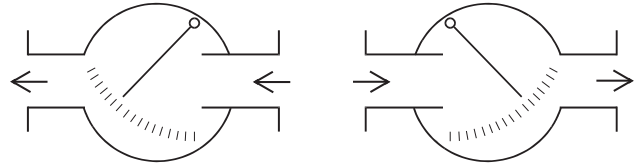

**right to left**

**left to right**

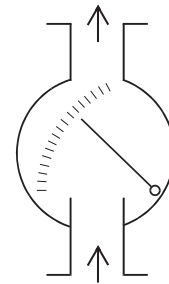

**bottom to top**

## Low Voltage Directive

Above 50 V AC/75 V DC, electrical components are subjected to the EU Low Voltage Directive (LVD). The user is required to verify their use accordingly.

## Accessories

Electrical accessories such as arc suppression relays found in our separate product data sheets.

## Safety notes

Operate the flow meters only up to the specified permitted operating pressure and the permitted operating temperature.

Avoid extreme pressure surges.

Pressure surges can cause glass breakage. The limit values given in the data sheet should be observed.

## Proper use

The user is responsible for assessing the suitability of the flow meters for his case of application, for use as prescribed and for material compatibility regarding the liquid product used in his process.

The manufacturer shall not be liable for any damage arising from incorrect or improper use of the devices.



**KLA**

Flap-type flow meters

---

The equipment from **Kirchner und Tochter** has been tested in compliance with applicable CE-regulations of the European Community. The respective declaration of conformity is available on request.

Subject to change without notice. The current valid version of our documents can be found at

The **Kirchner und Tochter** QM-System is certified in accordance with DIN EN ISO 9001:2015. The quality is systematically adapted to the continuously increasing demands.