

## Volume Booster Range Model VBP Series



### Superior Performance Throughout the Full Operational Range

-  SIL 3 Third Party Certified
- High Flow
- Full Flow 'Captive' Exhaust
- Additionally Functions as a Pressure Relief Valve
- Arctic Service Options
- Sensing Pilot / Valve Seat Assembly: Patent Pending
- Compact Modular Design
- 316L Stainless Steel
- Auto-Drain & Manual-Drain Filter Bowl Assembly Option

Product Features

Product

½" Volume Booster

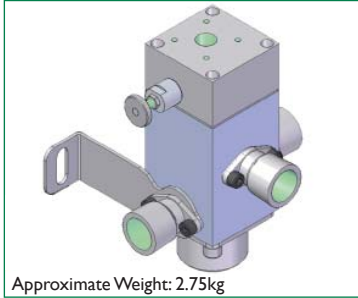

Approximate Weight: 2.75kg

½" Volume Booster with Filter

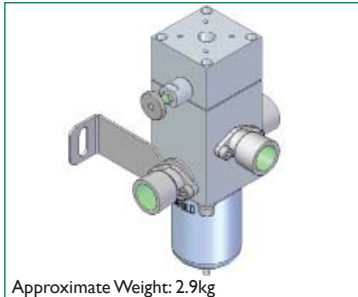

Approximate Weight: 2.9kg

1" Volume Booster

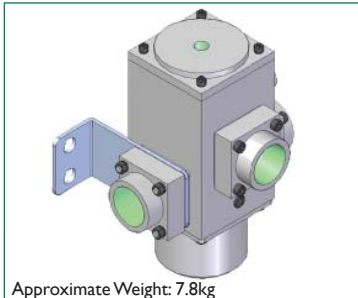

Approximate Weight: 7.8kg

1" Volume Booster with filter

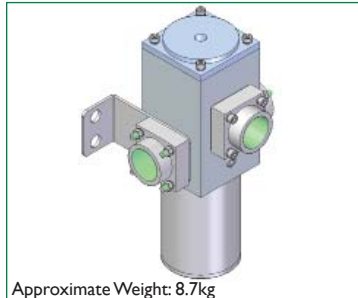

Approximate Weight: 8.7kg

2" Volume Booster

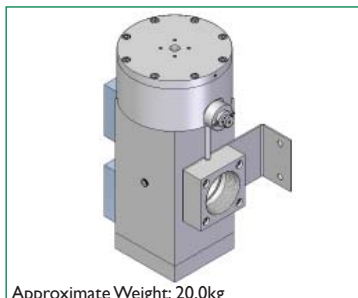

Approximate Weight: 20.0kg

Schematic

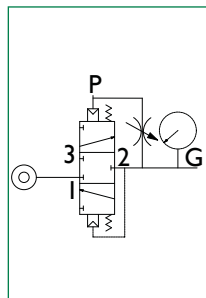
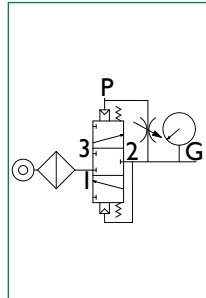
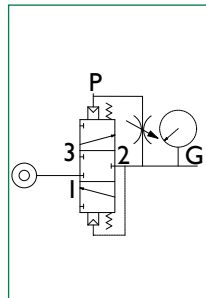
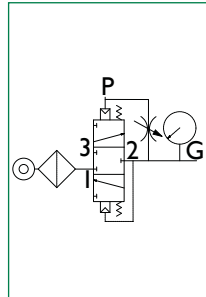
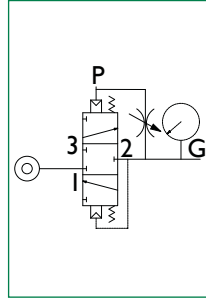

- This patented unique product offers equal internal operating forces to function the valve element to the open and vent positions.
- The EQUAL force allows identical inlet and vent orifice diameters: controlled actuators exhaust the air quickly resulting in reduced closing times.
- The performance of the Volume Booster eliminates the need for additional quick exhaust valves enabling reduced costs and installation time.
- Extremely compact modular design.
- Sensing pilot / valve seat assembly : Patent Pending.
- SIL 3 third party certified to IEC 61508 Parts 1 & 2. Consult Bifold.
- Additionally functions as a pressure relief valve.
- Soft seat design.
- Finely balanced design to minimise the impact of both downstream and upstream pressure variations.
- Block before bleed function.
- Captive Venting.
- This product can be incorporated within our 'AXIS'® valve actuator manifold systems.
- Bypass needle adjustment is fitted as standard across the range to eliminate system hunting.
- Service (without pressure applied) can be carried out without removal from the large diameter piping.
- Available with a filter booster combination.

Dimension Drawings



1/2" Volume Booster & Filter Booster

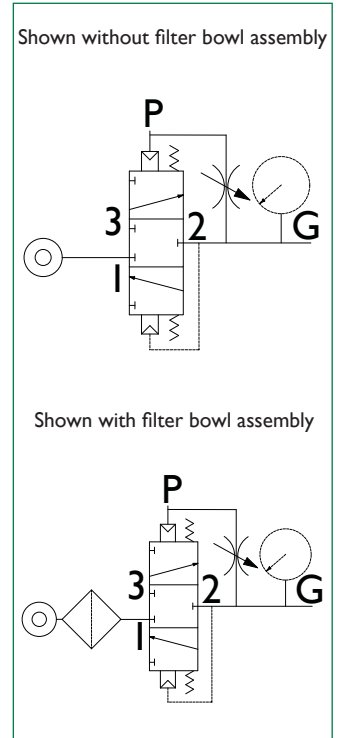
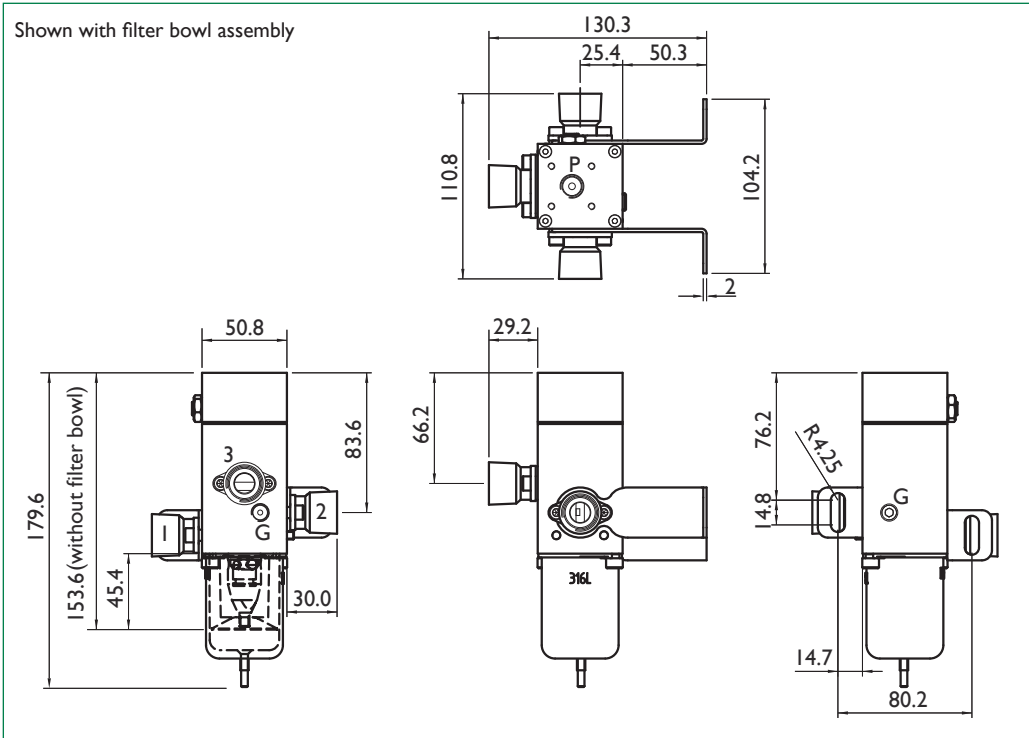

1" Volume Booster & Filter Booster

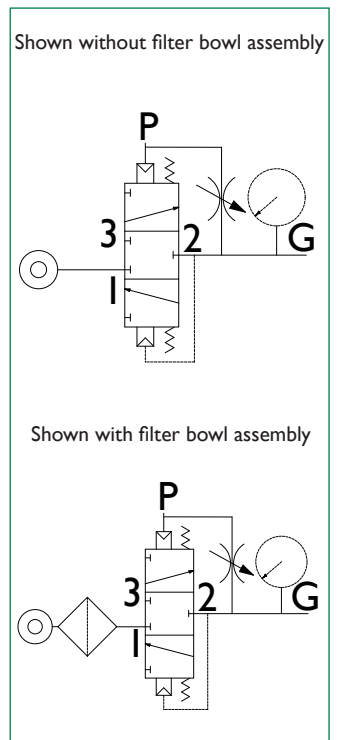
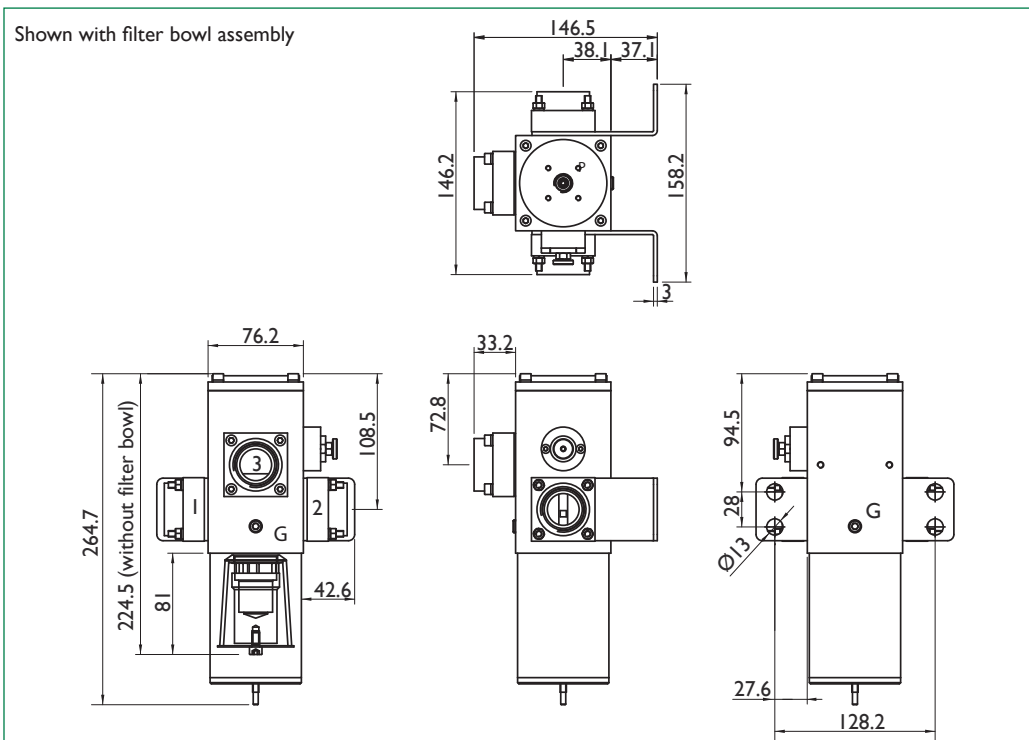

Dimension Drawings



2" Volume Booster

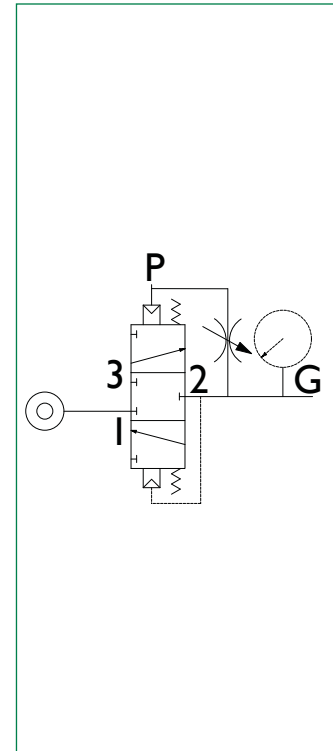
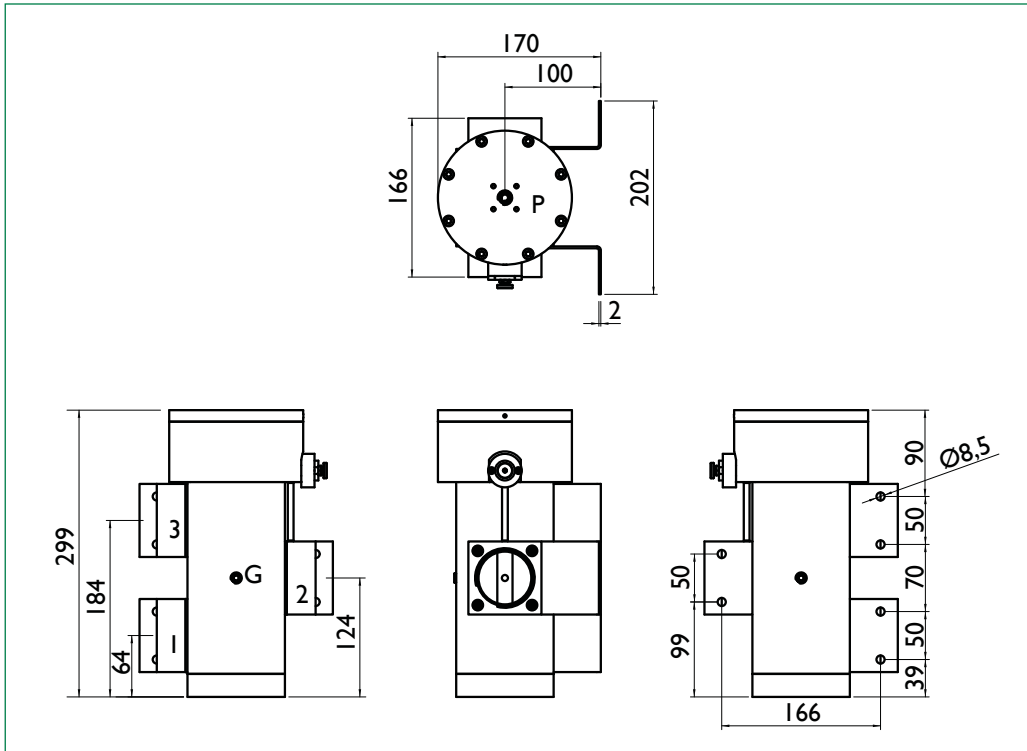

CAD Files Available

The Bifold technical team can supply CAD Files compatible with the customers CAD System in 2D and 3D formats. This enables Design Engineers to insert one of our images or drgs into their file, turning design into a less time consuming exercise.

Drgs available are:-

2D CAD Drawing in DWG format. Examples of 2D images shown on page 3 and above.

3D CAD Drawing in STEP format. Examples shown below.

Other formats are available, please contact our Technical Office for more information.

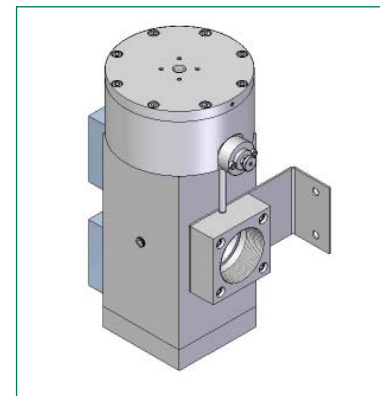
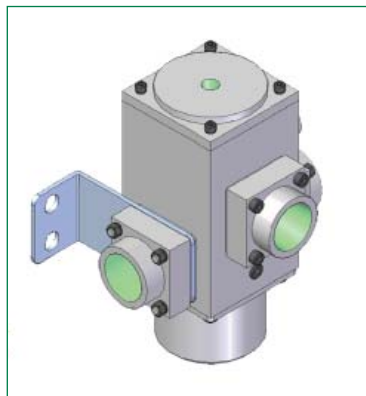
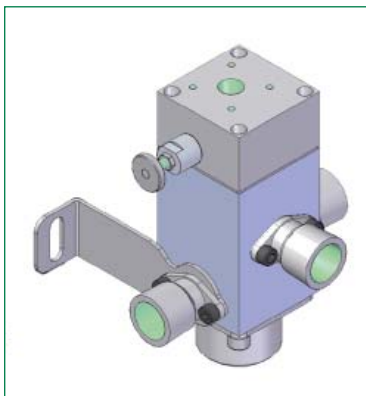

Overview



Product Description

The Bifold Volume Booster converts a low volume pressure signal into a 1:1 ratio high volume output. It is specifically designed for both modulating and "on - off" pilot pressure signals.

Operating Principles

When a low volume pilot pressure signal of 2 to 10 bar g is applied to the sensing port (P), the main valve assembly opens to allow high volume flow from the main inlet port (1) to the outlet port (2). When the sensing assembly detects that the outlet pressure is equal to the pilot pressure, the main valve moves to the 'all ports blocked' rest position and will remain in this position until there is a change in the pilot pressure or outlet pressure.

If the sensing head detects that the outlet is higher than the pilot pressure, the high flow exhaust opens to vent the excess pressure.

If the sensing head detects that the outlet pressure is too low, the main valve opens to recharge the system to the correct 1:1 ratio pressure.

Technical Data

Material grades - stainless steel 316L body as standard.

The springs are manufactured to BS2056, from 302S26 stainless steel as standard or Inconel X-750 (sour gas service).

The pilot port is 1/4" NPT.

Main ports are available as 1/4", 3/8" & 1/2" NPT sizes (1/2" Volume Booster) and 3/4" & 1" NPT sizes (1" Volume Booster) and 1 1/2" & 2" NPT sizes (2" Volume Booster).

Main valve seals are supplied in Viton as standard. Low temperature nitrile and silicone/fluorosilicone seals are available for arctic service.

Sensing head seals are supplied in PTFE encapsulated silicone as standard.

Fasteners are 18/10 grade stainless steel; equivalent to 316 grade steels.

Mounting brackets are supplied as standard.

Two gauge ports are 1/8" NPT. One port is plugged as standard.

Accuracy is within 5% (valve to pilot pressure).

Operating medias are air, natural gas, inert gases and sweet and sour gases.

Maximum valve inlet pressure is 15 bar g.

Operating temperature range -20°C to +180°C with viton seals as standard.

Operating temperature range -50°C to +40°C with low temperature nitrile/silicone seals.

Pilot pressure and outlet pressure range from 2 to 10 bar g.

Flow Capacity Cv Table

VOLUME BOOSTER FLOW CAPACITY Cv					
Volume Booster Conventional Schematic			Filter Booster		
Booster Size	Output	Exhaust	Booster Size	Output (5 bar, effective Cv)	Exhaust
1/2"	3.2	3.2	1/2"	9.3	3.2
1"	11.0	11.0	1"	29.0	11.0
2"	50.0	50.0			

Please see opening and closing time tables on page 10.

Product Options Available

Available with both manual and auto-drain filter bowl assemblies to combine a Filter Regulator and Volume Booster as one unit. A wide range of accessories are available, these include Check Valves and Flow Control Valves etc.

Pilot solenoid valve operated options available.

Pilot port available as BSPP and BSPT options.

Main ports available as BSPP & BSPT options.

Two gauge ports available as 1/4" NPT option or BSPP & BSPT.

Conventional Setup

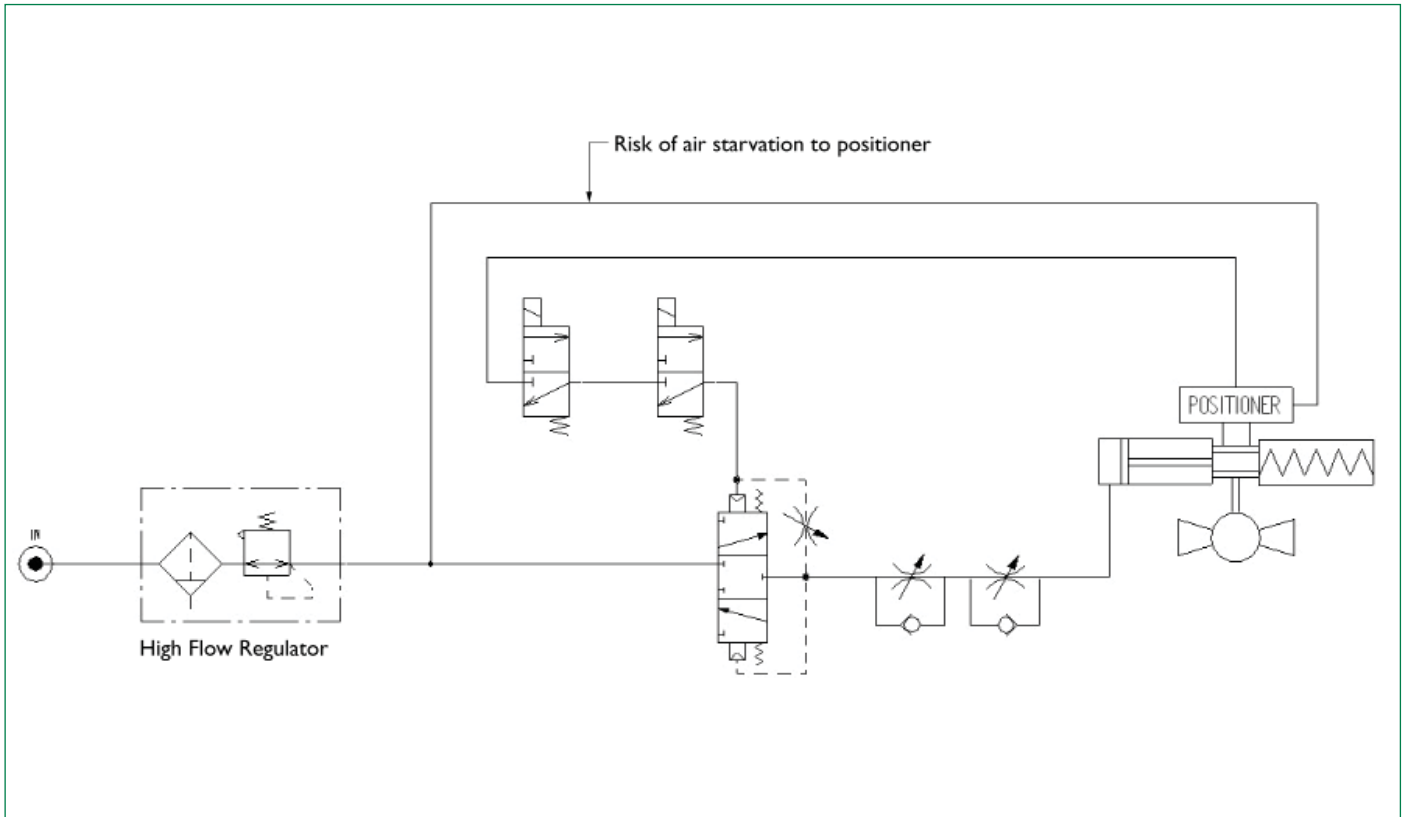

Bifold Simplified System Offers:-

- Up to 8 x faster opening.
- Up to 16 x faster closing.
- No risk of Positioner trip.
- Simple set up.
- Logic of circuit is identical for all actuator sizes. Only change required is to the size of the Filter Booster!

See Catalogue 03:- AXIS® Manifold System.  
See Catalogue 13:- Model HIPEX Series.

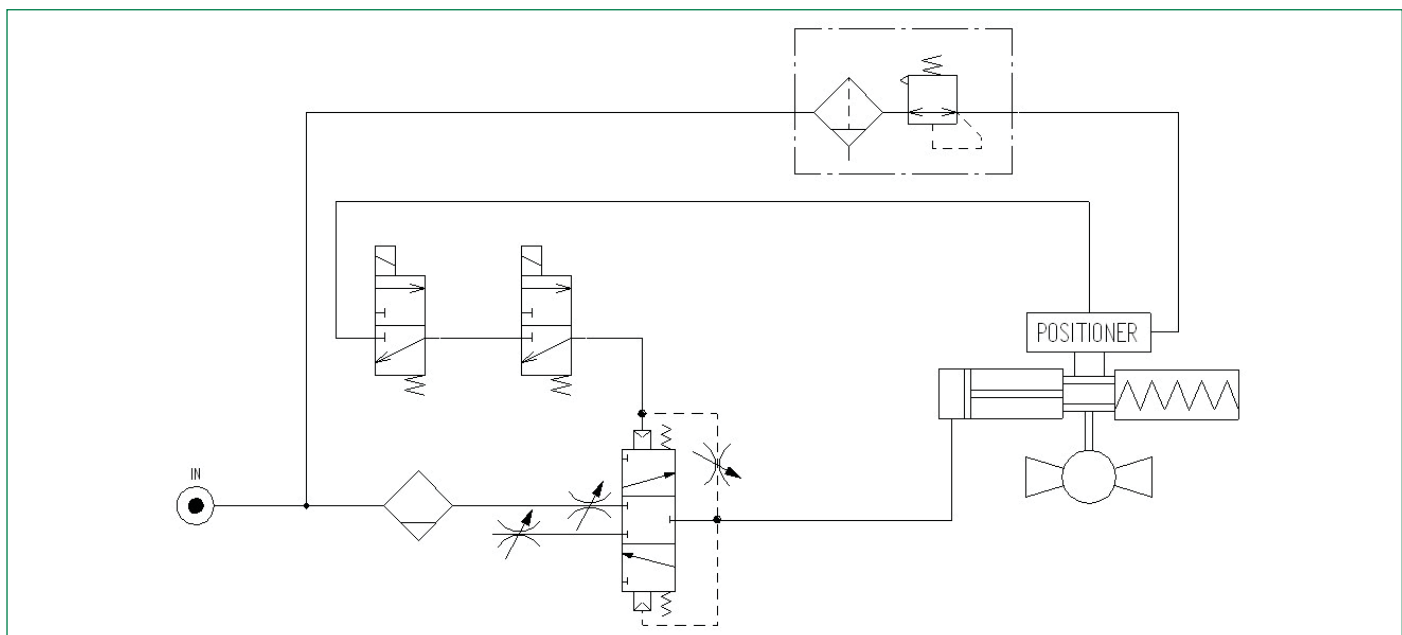

Simplified Circuits



Positioner Circuits Simplified

The circuit below shows a 1/4" Filter Module and a 1/4" Logic Module, within a standard circuit, along with a 1/2" HIPEX valve and 1/2" Filter Booster. For larger circuits, simply select a larger Filter Booster. If required, change the HIPEX valve where applicable.

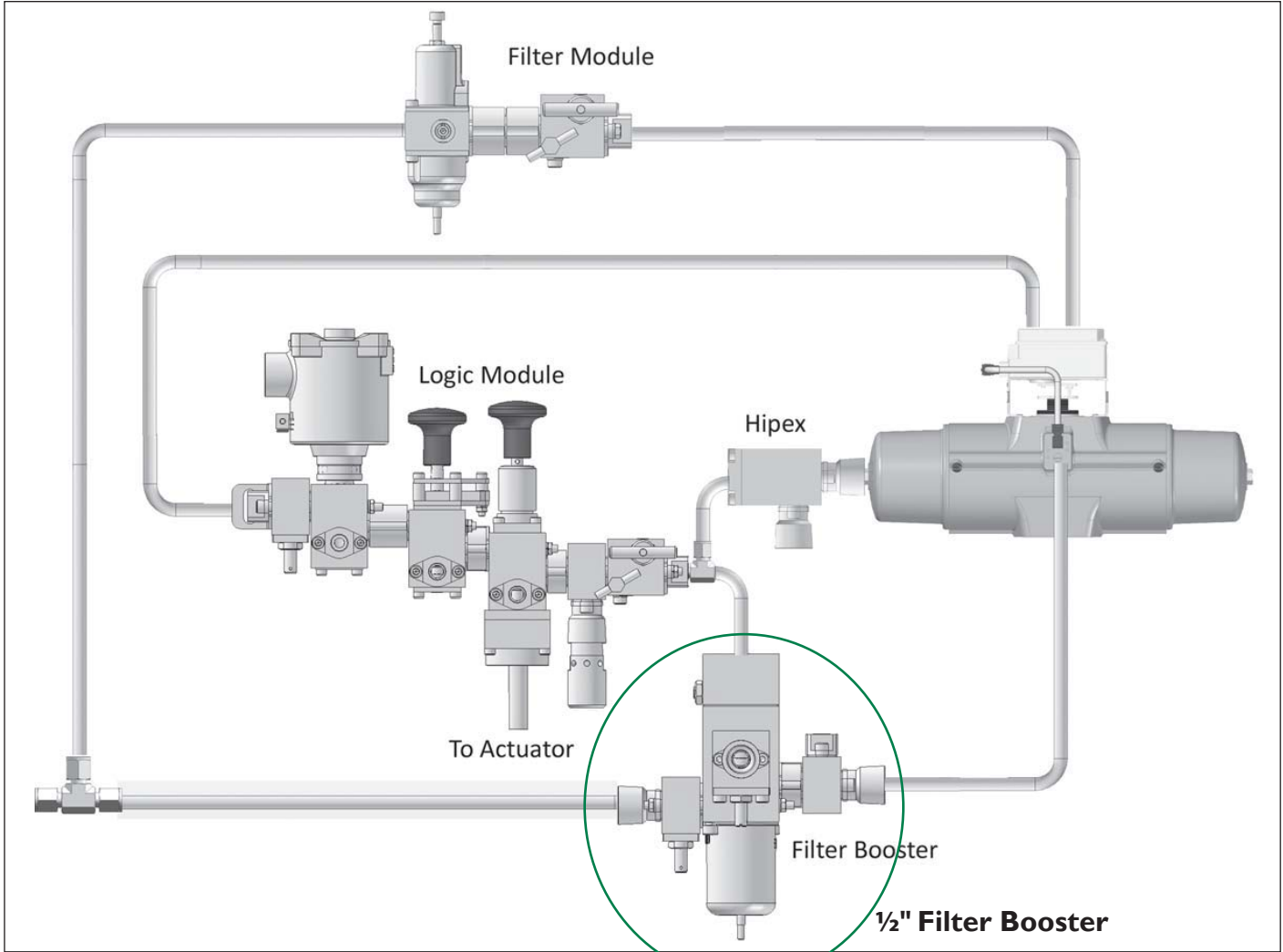

1" Filter Booster

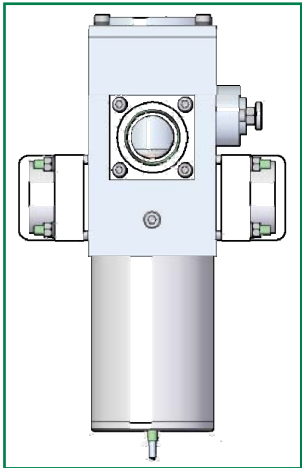

**Positioner Circuits - Simplified**  
For larger circuits, simply select a larger Filter Booster.

### Conventional Tubed System

Conventional Volume Boosters have a much reduced venting Cv compared to inlet Cv; consequently multiple units are often required to achieve fast actuator closing times.

The picture below shows a traditionally tubed system with multiple Filter Regulators and Multiple Volume Boosters.

**Disadvantages with this system are:-**

**This system = Slower Response Times  
Requires Balancing of Filter Regulators**

- No speed control.
- More leakage points.
- Untidy and complex tubing/extra fittings.
- Requirement to balance Filter Regulators.
- Complicated installation.
- Increase in overall system cost.

**Improve System Design - Use Bifold Volume Boosters with a high venting Cv**

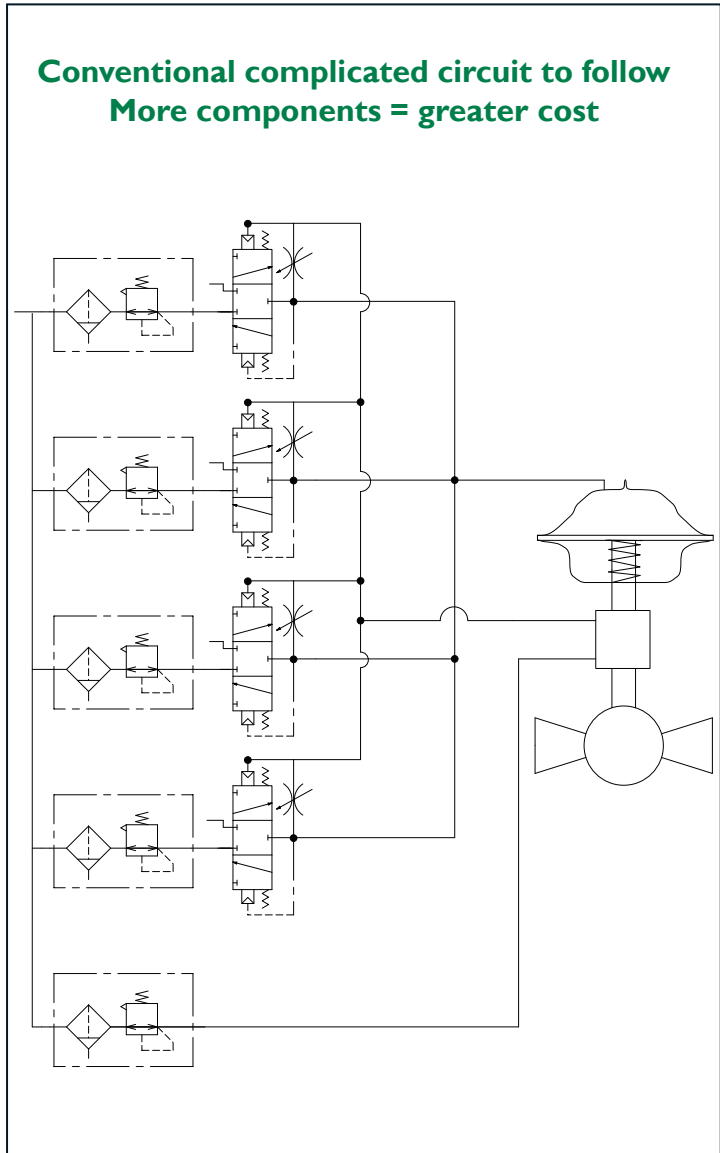

Booster System



Bifold Filter Booster System

The picture below shows a simple tubed system with ONE Bifold Filter Regulator and ONE Bifold Volume Booster.

Advantages with this system are:-

This system = Faster Response Times  
Simple to Install

- Optional inlet and venting speed control.
- Faster acting than 4 Filter regulators & 4 Boosters.
- Tidy and simple tubing/reduced fittings.
- Sizes available up to 2".
- Simple to install.
- Lowest overall system cost.

LOWEST COST SOLUTION



Simple circuit to follow  
Fewer components = Lowest cost solution

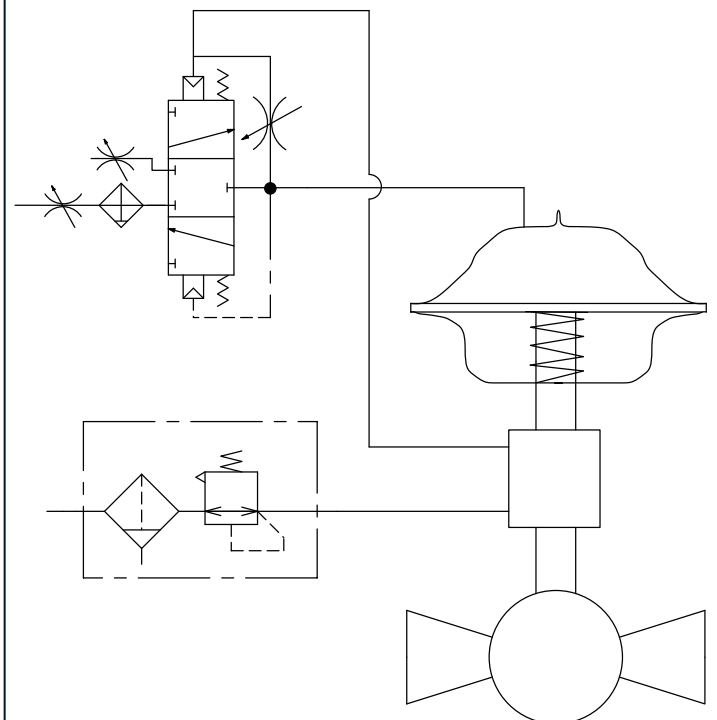

## Selection Chart

### 1/2" & 1" Volume Booster Opening and Closing Times

**50 litre actuator** - where stroke completes at between 1.9 bar and 2.3 bar. Set pressure 5 bar. Upstream pressure greater than 10 bar.

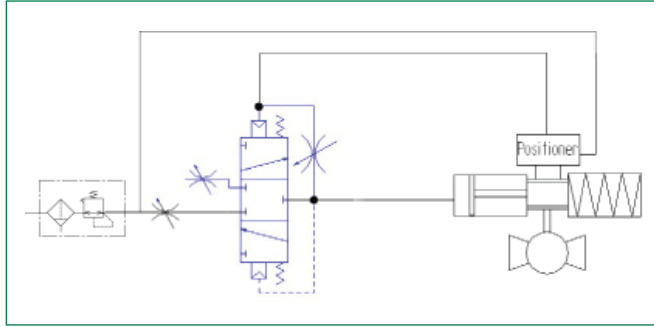

**CONVENTIONAL SCHEMATIC** (Filter Regulator and Booster on the flow line)

Booster Size	Pressure (Bar)	ESD Open Time (secs)	ESD Closing Time (secs)
1/2"	5	8.9	8.8
1"	5	2.8	2.5

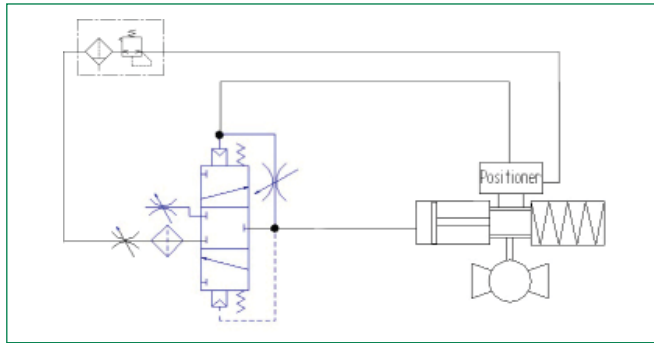

**FILTER BOOSTER** (Filter Regulator off the flowline)

Booster Size	Pressure (Bar)	ESD Open Time (secs)	ESD Closing Time (secs)
1/2"	4	4.0	7.9
1/2"	5	3.1	8.8
1/2"	6	2.3	9.3
1"	4	1.1	1.9
1"	5	1.2	2.5
1"	6	0.8	3.1

### VBP Selection Chart - Ordering Example

<b>VBP</b>	Volume Booster piston type	Standard service stainless steel	Model Code
<b>04</b>	1/4" NPT	<b>16</b> 1" NPT	Port Sizes
<b>06</b>	3/8" NPT	<b>24</b> 1 1/2" NPT	
<b>08</b>	1/2" NPT	<b>32</b> 2" NPT	
<b>12</b>	3/4" NPT		
<b>11</b>	Ratio pilot pressure to valve pressure (1:1)		Ratio
<b>V</b>	Viton (standard)		Seal Materials
<b>AL</b>	Fluorosilicone (arctic service)		
<b>AD</b>	Auto-drain*		Options
<b>MD</b>	Manual-drain*		
<b>X4</b>	40-50 Micron element*		Option
<b>L115</b>	No brackets		Option
<b>L116</b>	Knurled drain screw		Option
<b>XX</b>	Revision number	(current revision to be advised on receipt of order).	Revision Number
<b>VBP-08 - 11 - AL - MD - X4 - L115 - L116 - 02</b>			Ordering Example

\*Filter booster only. For alternative filter micron ratings please contact our office for details.  
1 1/2" & 2" Volume Booster presently not available as a Filter Booster.

## HIPEX Series



The Volume Booster range can be used in conjunction with the NEW Model HIPEX Series high flow, 2/2 exhaust valve range. See Catalogue 13:- Model HIPEX Series.

### ½" HIPEX Valve



Approximate Weight: 0.8kg

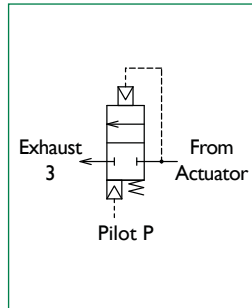

### 1" HIPEX Valve

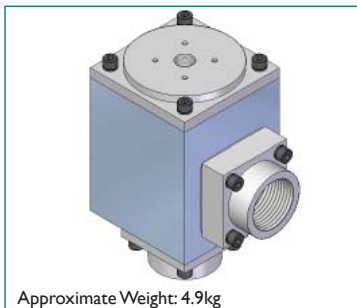

Approximate Weight: 4.9kg

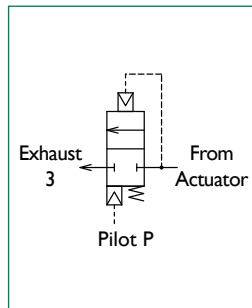

### 2" HIPEX Valve

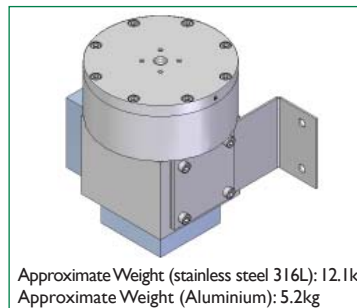

Approximate Weight (stainless steel 316L): 12.1kg  
Approximate Weight (Aluminium): 5.2kg

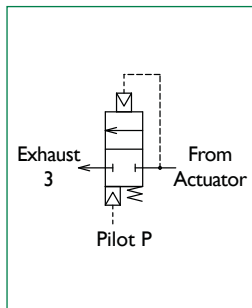

- Very high controlled exhaust flow, up to twice the equivalent Quick Exhaust Valve.
- Exhaust flow is proportional to the differential between inlet and pilot pressures.
- The valve is automatic in operation and requires no adjustment.
- The valve operates on a 1:1 pilot pressure to valve pressure ratio at pressures between 2 and 10 bar g.
- Specifically designed for high flow valve actuator exhausting when accurate partial close testing is required.
- For very fast valve actuator closing, multiple HIPEX units can be fitted to the system.
- Extremely compact modular design.
- Sensing pilot / valve seat assembly : Patent Pending.
- Soft seat design.
- Finely balanced design to minimise the impact of both downstream and upstream pressure variations.

## Benefits of using the HIPEX Series

The Bifold HIPEX Valve is a 2-way, normally closed directional control valve with a venting flow rate proportional to the differential pressure between the inlet and the pilot signal pressures. It is specifically designed for both modulating and "on-off" pilot pressure signals.

When the pilot pressure signal is equal to or above the main valve inlet pressure, the valve exhaust port remains closed.

#### **Partial close testing function**

When the pilot pressure falls below the main valve inlet pressure, the valve quickly exhausts the excess pressure until both the valve and pilot pressures are again equal, then the exhaust port closes.

#### **Pressure Relief Function**

If the main valve inlet pressure increases above the pilot pressure, the valve automatically exhausts the excess valve actuator pressure.

#### **Optional**

The HIPEX valve can be supplied with two exhaust ports. This provides an additional advantage that one exhaust port can be connected to the valve actuator for "closed loop" systems that reduce the need for additional valves, fittings and labour time. The HIPEX can also be supplied with exhaust speed controls fitted as a complete solution.

Ideal for operation in conjunction with the " Bifold Volume Booster" and 'AXIS'® valve actuator manifold ranges.