



HYDRAULIC GEAR  
PUMPS AND  
MOTORS

**MAGNUM**<sup>®</sup>

---

## INDEX

---

Section	Page
FEATURES.....	3
GENERAL DATA .....	6
PUMP PERFORMANCE CURVES .....	8
MOTOR PERFORMANCE CURVES .....	15
SINGLE UNITS DIMENSIONS .....	22
MULTIPLE PUMPS .....	25
MULTIPLE PUMPS DIMENSIONS .....	32
VERSIONS (OUTBOARD BEARINGS FOR SHAFTS) .....	42
DRIVE SHAFTS .....	47
MOUNTING FLANGES .....	48
PORTS .....	51
CHANGING ROTATION .....	56
INSTRUCTIONS.....	57
HOW TO ORDER.....	58

01/07.2005



Modification from former edition.

## FEATURES

Modular design and versatility are the main features of “MAGNUM” series gear pumps and motors. Mounting flange, body and rear cover can be easily assembled to obtain multiple pumps of same or different groups available in standard version, common inlet or separated stages. Wide selection of drive shafts and mounting flanges in SAE version with the possibility of integrated outboard bearing to suit all the applications with axial and radial load on the drive shaft.

Port locations available in side or rear locations, and combination of side and rear locations. The low level of noise emission with the high volumetric and overall efficiencies ensure reliability and long working life in heavy duty applications.

### DISPLACEMENTS

From 1.05 in<sup>3</sup>/rev (17,28 cm<sup>3</sup>/rev)  
To 7.66 in<sup>3</sup>/rev (125,63 cm<sup>3</sup>/rev)

### PRESSURE

Max. continuous 4060 psi (280 bar)  
Max. intermittent 4350 psi (300 bar)  
Max. peak 4640 psi (320 bar)

### MAX. SPEED

3000 min<sup>-1</sup>

- Wide range of drive shafts and mounting flanges in SAE version
- More choices of port locations
- Integrated outboard bearing for heavy duty applications
- Multiple units available in standard version, common inlet and separated stages
- Exceptional working life expectancy

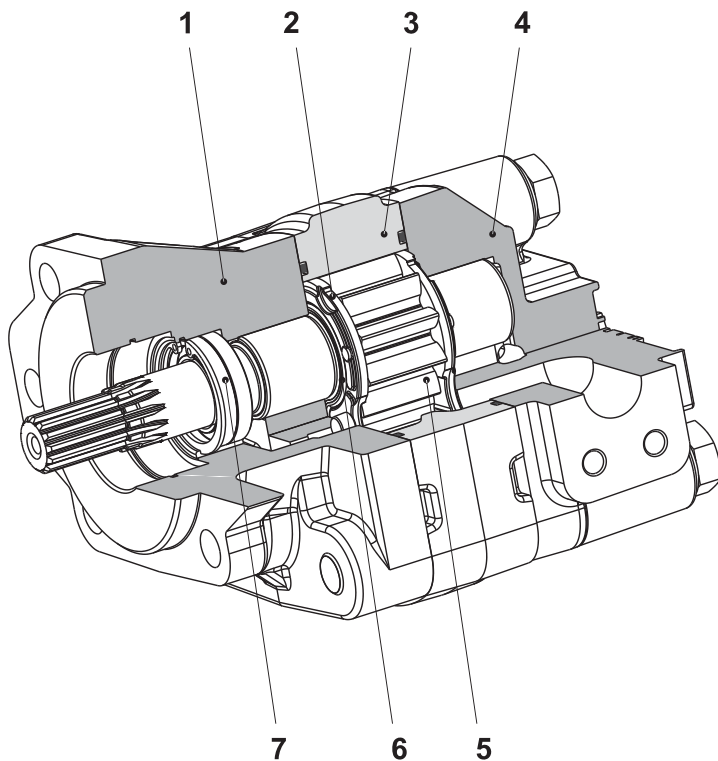

1	Mounting flange
2	Thrust plate
3	Body
4	Rear cover
5	Gear
6	Seal
7	Shaft seal

01/07.2005

## FEATURES

Construction	External gear type pumps and motors
Mounting	SAE flanges
Line connections	Screw and flange
Direction of rotation (looking at the drive shaft)	Anti-clock (S) - clockwise (D) - reversible external drain (R) reversible internal drain (B)
Inlet pressure range for pumps	10 ÷ 44 psi - [0,7 ÷ 3 bar (abs.)]
Max back pressure for single rotation motors	$p_1$ (continuous) max 73 psi (5 bar)
	$p_2$ (for 20 s) max 116 psi (8 bar)
	$p_3$ (for 8 s) max 218 psi (15 bar)
Max drain line pressure on reversible rotation motors	73 psi (5 bar)
Max back pressure on the series motors	2175 psi (150 bar)
Fluid temperature range	See table (1)
Fluid	Mineral oil based hydraulic fluids to ISO/DIN and fire resistant fluids [see table (1)]. For other fluids please consult our technical sales department.
Viscosity range	From 60 to 456 SSU [12 to 100 mm <sup>2</sup> /s (cSt)] recommended
	Up to 3410 SSU [750 mm <sup>2</sup> /s (cSt)] permitted
Filtering requirement	See table (2)

Replaces: 01/07.2005

**Tab. 1**

Type	Fluid composition	Max pressure psi - (bar)	Max speed min <sup>-1</sup>	Temperature °F - (°C)			Seals (◆)
				Min	Max continuous	Max peak	
ISO/DIN	Mineral oil based hydraulic fluid to ISO/DIN	See page 6	See page 6	-13 (-25)	176 (80)	212 (100)	<b>N</b>
				-13 (-25)	230 (110)	257 (125)	<b>N - H</b>
HFA	Oil emulsion in water 5 ÷ 15% of oil	725 (50)	1500	36 (2)	131 (55)		<b>N</b>
HFB	Water emulsion in oil 40% of water	1740 (120)	1500	36 (2)	140 (60)		<b>N</b>
HFC	Water - glycol	1450 (100)	1500	-4 (-20)	140 (60)		<b>N Bz</b>
HFD	Phosphate ester	2175 (150)	1500	14 (-10)	176 (80)		<b>V Bz</b>

(◆) **N**= Buna N (standard) - **N-H**= Buna N and high back pressure shaft seals - **V**= Viton  
**N Bz**= Buna N and Bronze thrust plates - **V Bz**= Viton and Bronze thrust plates

**Tab. 2** ○

Working pressure psi (bar)	$\Delta p < 2030$	$2030 < \Delta p < 3045$	$\Delta p > 3045$
	$\Delta p < (140)$	$(140) < \Delta p < (210)$	$\Delta p > (210)$
Contamination class NAS 1638	10	9	8
Contamination class ISO 4406:1999	21/19/16	20/18/15	19/17/14
Achieved with filter $\beta_{10(c)} \geq 200$ according to ISO 16889	-	10 $\mu$ m	10 $\mu$ m
Achieved with filter $\beta_{25(c)} \geq 200$ according to ISO 16889	25 $\mu$ m	-	-

Casappa recommends to use its own production filters:



○ 02/06.2012

### GENERAL NOTES

Available with different inlet and outlet ports.  
 If you use fire resistant fluids, specify the fluid type when ordering.  
 For more information please consult our technical sales department.

## FEATURES

### DEFINITION OF ROTATION DIRECTION LOOKING AT THE DRIVE SHAFT

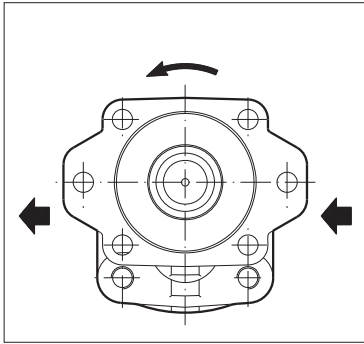

**Anti-clock rotation**

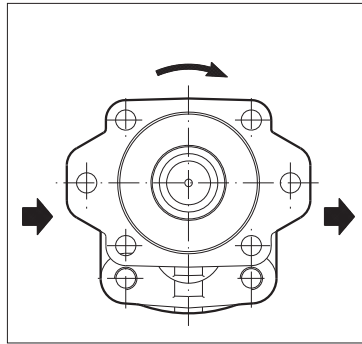

**Clockwise rotation**

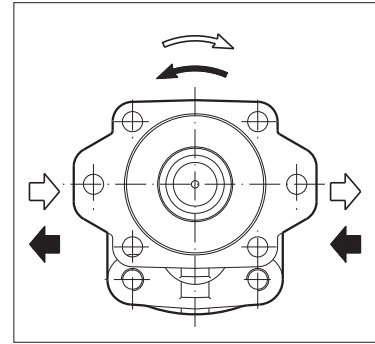

**Reversible rotation**

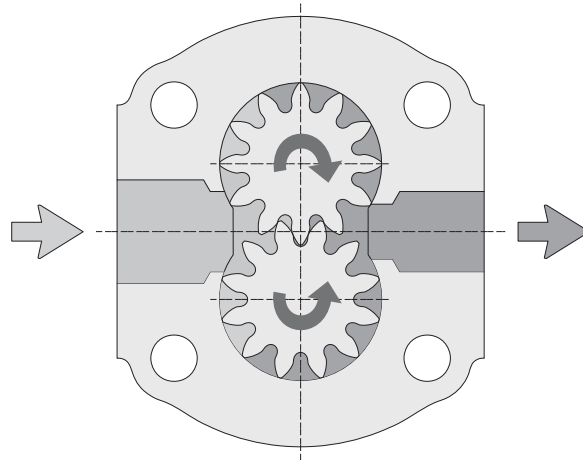

### PRESSURE DEFINITION

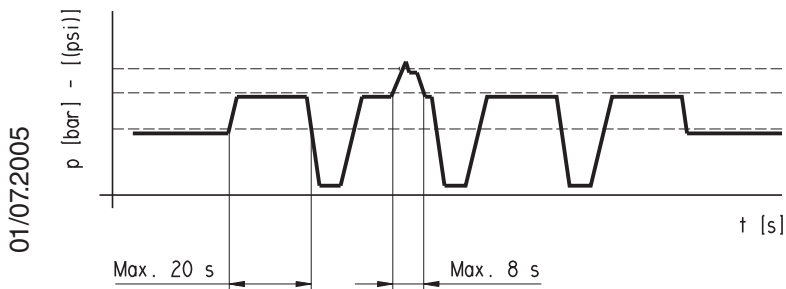

$p_1$  Max. continuous pressure  
 $p_2$  Max. intermittent pressure  
 $p_3$  Max. peak pressure

## GENERAL DATA PUMPS AND MOTORS

Pump type HDP Motor type HDM	Displacement  in <sup>3</sup> /rev (cm <sup>3</sup> /rev)	Max. pressure			Max. speed	Min. speed  min <sup>-1</sup>
		P <sub>1</sub>	P <sub>2</sub>	P <sub>3</sub>		
		psi (bar)				
<b>HD. 30•17</b>	1.05 (17,28)	4060 (280)	4350 (300)	4640 (320)	3000	400
<b>HD. 30•22</b>	1.34 (21,99)	4060 (280)	4350 (300)	4640 (320)	3000	400
<b>HD. 30•24</b>	1.47 (24,03)	4060 (280)	4350 (300)	4640 (320)	3000	400
<b>HD. 30•27</b>	1.63 (26,70)	4060 (280)	4350 (300)	4640 (320)	3000	400
<b>HD. 30•34</b>	2.11 (34,56)	3915 (270)	4205 (290)	4495 (310)	3000	400
<b>HD. 30•38</b>	2.40 (39,27)	3915 (270)	4205 (290)	4495 (310)	3000	400
<b>HD. 30•43</b>	2.68 (43,98)	3770 (260)	4060 (280)	4350 (300)	3000	400
<b>HD. 30•51</b>	3.16 (51,83)	3335 (230)	3770 (260)	4060 (280)	2500	300
<b>HD. 30•56</b>	3.45 (56,55)	3118 (215)	3553 (245)	3843 (265)	2500	300
<b>HD. 30•61</b>	3.74 (61,26)	2900 (200)	3335 (230)	3625 (250)	2000	250
<b>HD. 30•73</b>	4.50 (73,82)	2755 (190)	3045 (210)	3335 (230)	1700	250
<b>HD. 30•82</b>	4.98 (81,68)	2465 (170)	2755 (190)	3045 (210)	1500	250
<b>HD. 35•40</b>	2.47 (40,46)	3915 (270)	4060 (280)	4495 (310)	3000	400
<b>HD. 35•50</b>	3.12 (51,10)	3915 (270)	4060 (280)	4495 (310)	3000	400
<b>HD. 35•63</b>	3.90 (63,88)	3915 (270)	4060 (280)	4495 (310)	3000	400
<b>HD. 35•71</b>	4.42 (72,40)	3625 (250)	4060 (280)	4350 (300)	3000	400
<b>HD. 35•80</b>	4.94 (80,91)	3625 (250)	4060 (280)	4350 (300)	3000	400
<b>HD. 35•90</b>	5.59 (91,56)	3335 (230)	3770 (260)	4060 (280)	2700	400
<b>HD. 35•100</b>	6.10 (100,08)	3045 (210)	3480 (240)	3770 (260)	2700	400
<b>HD. 35•112</b>	6.88 (112,85)	2755 (190)	3190 (220)	3480 (240)	2700	400
<b>HD. 35•125</b>	7.66 (125,63)	2465 (170)	2900 (200)	3190 (220)	2500	250

p<sub>1</sub> = Max. continuous pressure

p<sub>2</sub> = Max. intermittent pressure

p<sub>3</sub> = Max. peak pressure

The values in the table refer to unidirectional pumps and motors.

Reversible pump and motors max pressures are 15% lower than those shown in table.

For different working conditions please consult our sales department.

01/07.2005

## GENERAL DATA PUMPS AND MOTORS

Replaces: 01/07.2005

<b>Q</b>	US gpm (l/min)	Flow
<b>M</b>	lbf in (Nm)	Torque
<b>P</b>	HP (kW)	Power
<b>V</b>	in <sup>3</sup> /rev (cm <sup>3</sup> /rev)	Displacement
<b>n</b>	min <sup>-1</sup>	Speed
<b>Δp</b>	psi (bar)	Pressure

### Efficiencies

		Pumps	Motor
$\eta_v = \eta_v(V, \Delta p, n)$	Volumetric efficiency	(≈ 0,98)	(≈ 0,97)
$\eta_{hm} = \eta_{hm}(V, \Delta p, n)$	Hydro-mechanical efficiency	(≈ 0,90)	(≈ 0,88)
$\eta_t = \eta_v \cdot \eta_{hm}$	Overall efficiency	(≈ 0,88)	(≈ 0,85)

#### Design calculations for pump ○

$$Q = Q_{theor.} \cdot \eta_v$$

$$Q_{theor.} = \frac{V \text{ (cm}^3\text{/rev)} \cdot n \text{ (min}^{-1}\text{)}}{1000} \quad [\text{l/min}]$$

$$M = \frac{M_{theor.}}{\eta_{hm}} \quad [\text{Nm}]$$

$$M_{theor.} = \frac{\Delta p \text{ (bar)} \cdot V \text{ (cm}^3\text{/rev)}}{62,83}$$

$$P_{IN} = \frac{P_{OUT}}{\eta_t} \quad [\text{kW}]$$

$$P_{OUT} = \frac{\Delta p \text{ (bar)} \cdot Q \text{ (l/min)}}{600}$$

#### Design calculations for motor ○

$$Q = \frac{Q_{theor.}}{\eta_v} \quad [\text{l/min}]$$

$$Q_{theor.} = \frac{V \text{ (cm}^3\text{/rev)} \cdot n \text{ (min}^{-1}\text{)}}{1000}$$

$$M = M_{theor.} \cdot \eta_{hm} \quad [\text{Nm}]$$

$$M_{theor.} = \frac{\Delta p \text{ (bar)} \cdot V \text{ (cm}^3\text{/rev)}}{62,83}$$

$$P_{IN} = \frac{\Delta p \text{ (bar)} \cdot Q \text{ (l/min)}}{600} \quad [\text{kW}]$$

$$P_{OUT} = P_{IN} \cdot \eta_t$$

○ 02/06.2012

**Note:** Diagrams providing approximate selection data will be found on subsequent pages.

**HDP 30**

**MAGNUM 30 GEAR PUMPS PERFORMANCE CURVES**

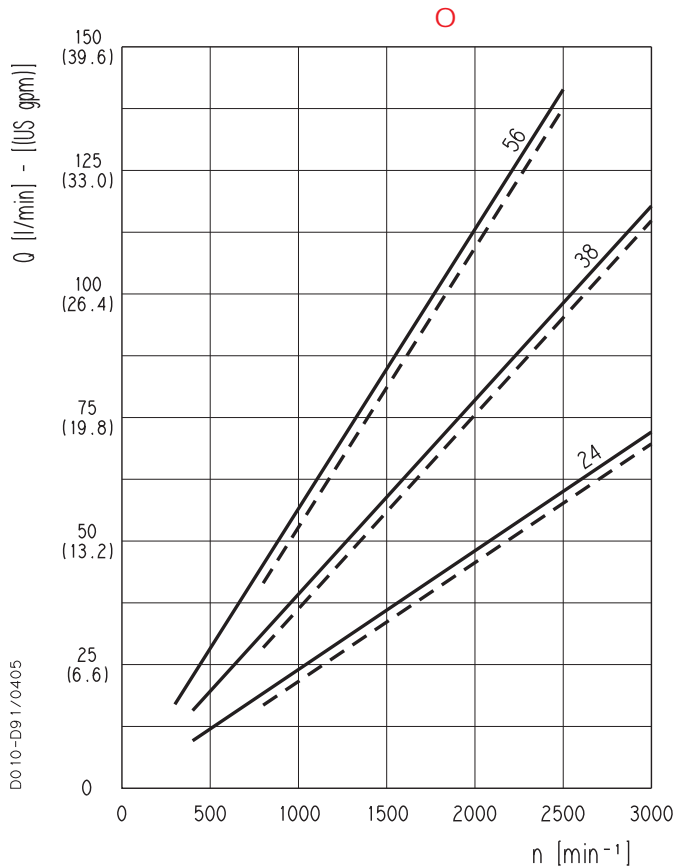
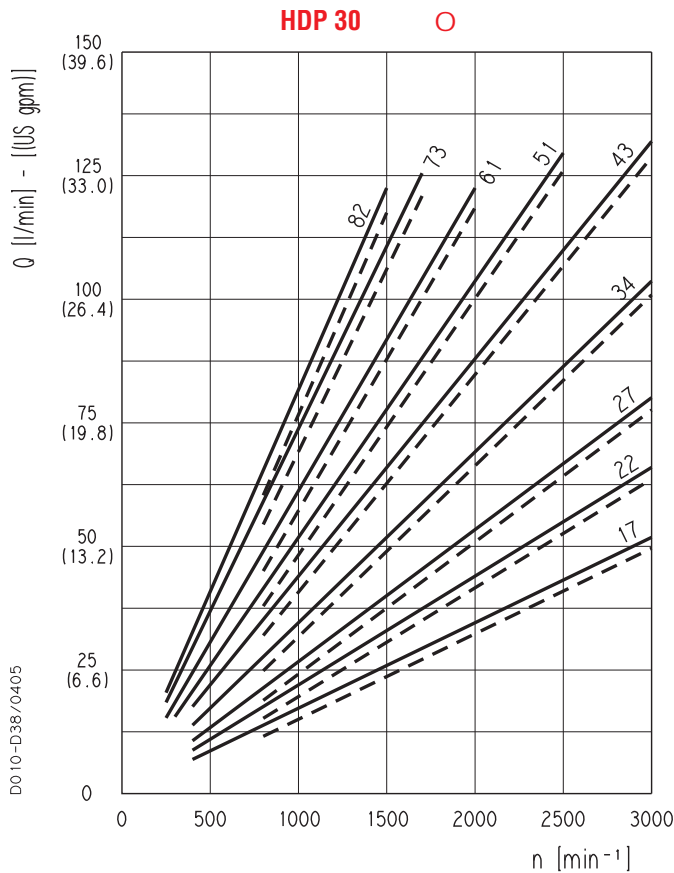

<b>HDP 30•17</b>	— 290 psi (20 bar)
	- - 4060 psi (280 bar)
<b>HDP 30•22</b>	— 290 psi (20 bar)
	- - 4060 psi (280 bar)
<b>HDP 30•27</b>	— 290 psi (20 bar)
	- - 4060 psi (280 bar)
<b>HDP 30•34</b>	— 290 psi (20 bar)
	- - 3915 psi (270 bar)
<b>HDP 30•43</b>	— 290 psi (20 bar)
	- - 3770 psi (260 bar)
<b>HDP 30•51</b>	— 290 psi (20 bar)
	- - 3335 psi (230 bar)
<b>HDP 30•61</b>	— 290 psi (20 bar)
	- - 2900 psi (200 bar)
<b>HDP 30•73</b>	— 290 psi (20 bar)
	- - 2755 psi (190 bar)
<b>HDP 30•82</b>	— 290 psi (20 bar)
	- - 2465 psi (170 bar)

**New displacements**

<b>HDP 30•24</b>	— 290 psi (20 bar)
	- - 4060 psi (280 bar)
<b>HDP 30•38</b>	— 290 psi (20 bar)
	- - 3915 psi (270 bar)
<b>HDP 30•56</b>	— 290 psi (20 bar)
	- - 3118 psi (215 bar)

Replaces: 01/07.2005

○ 02/06.2012

**HDP 30**

**MAGNUM 30 GEAR PUMPS PERFORMANCE CURVES**

**HDP 30•17**

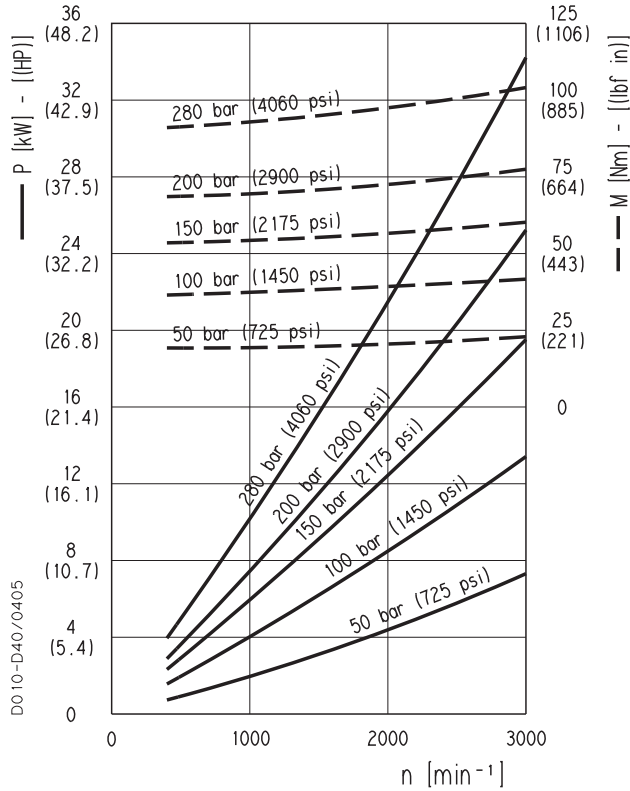

**HDP 30•22**

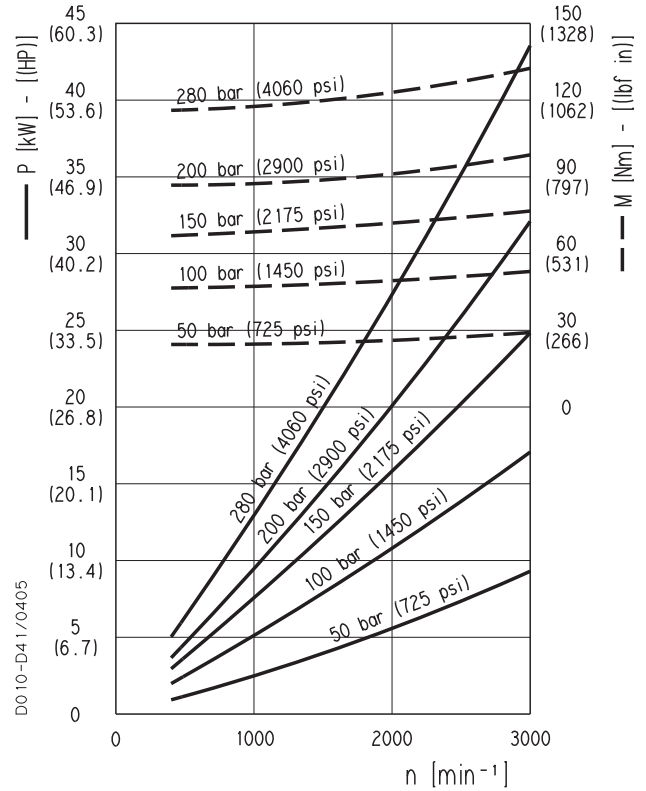

**HDP 30•24**

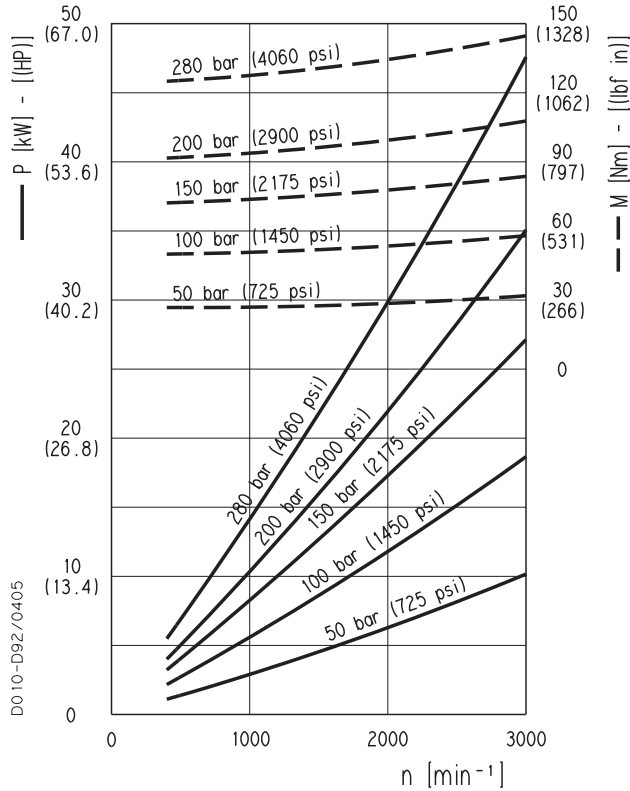

**HDP 30•27**

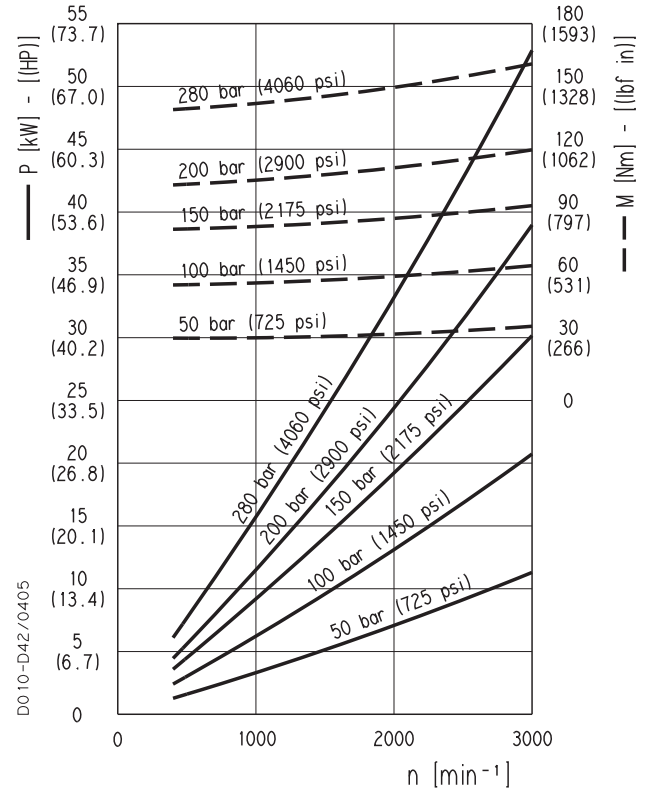

01/07.2005

**HDP 30**

**MAGNUM 30 GEAR PUMPS PERFORMANCE CURVES**

**HDP 30•34**

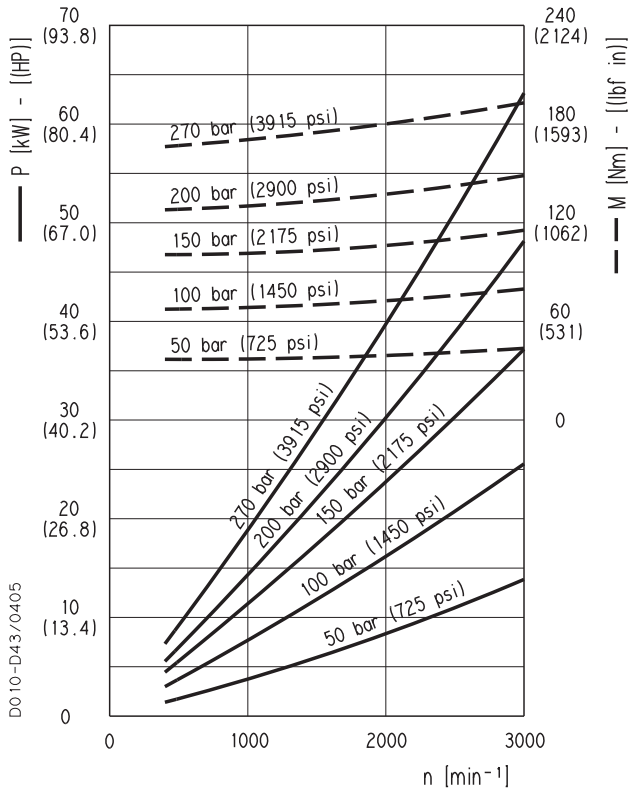

**HDP 30•38**

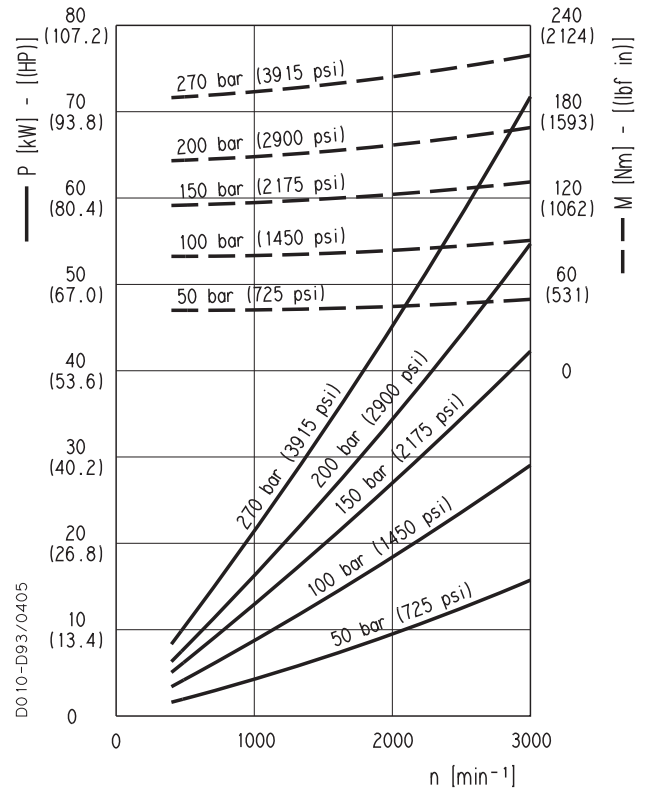

**HDP 30•43**

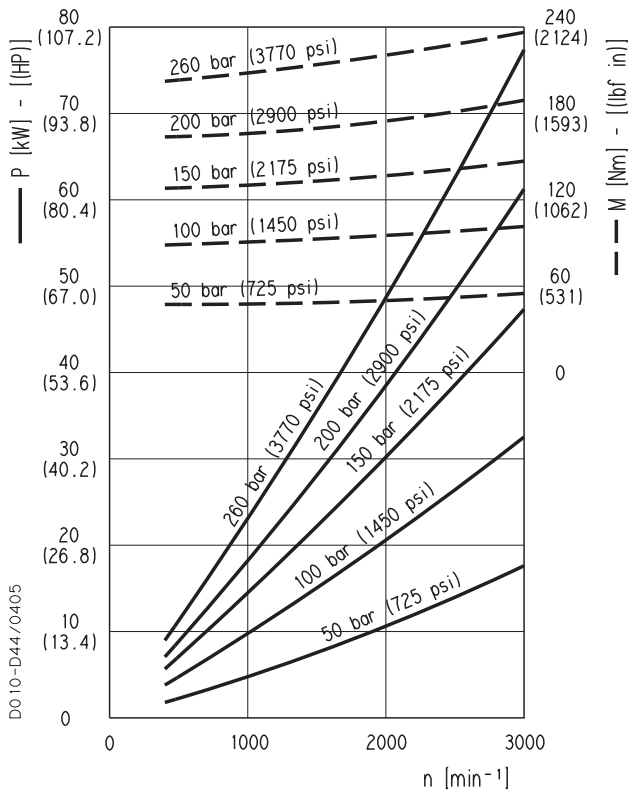

**HDP 30•51**

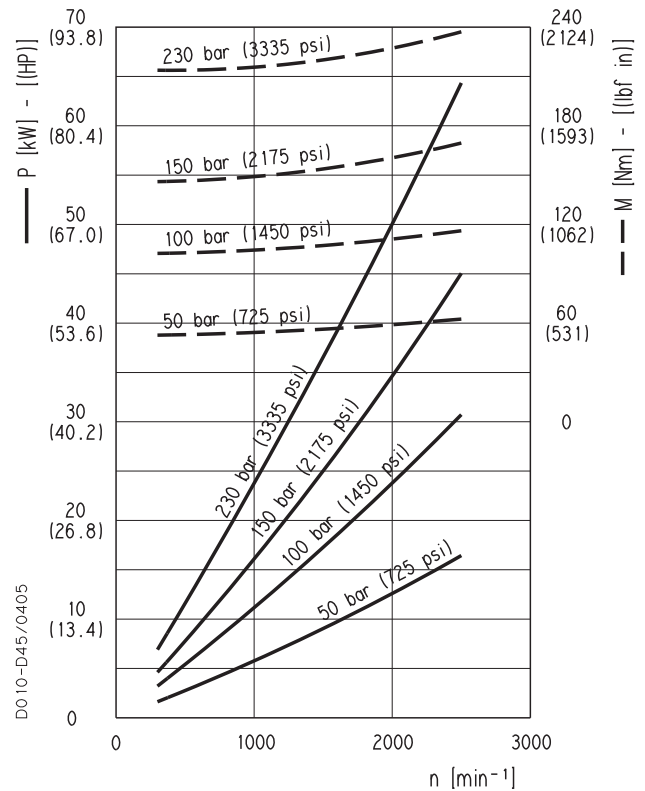

01/07.2005

**HDP 30**

**MAGNUM 30 GEAR PUMPS PERFORMANCE CURVES**

**HDP 30•56**

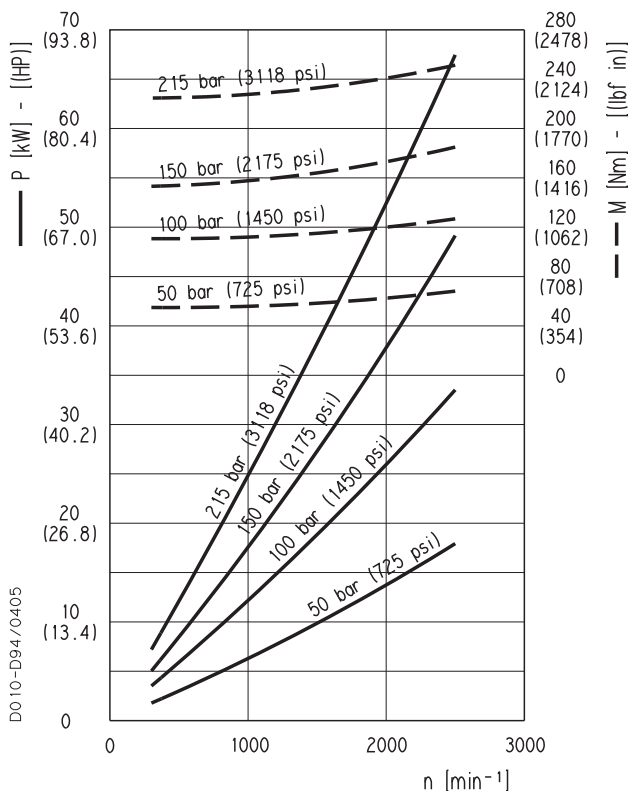

**HDP 30•61**

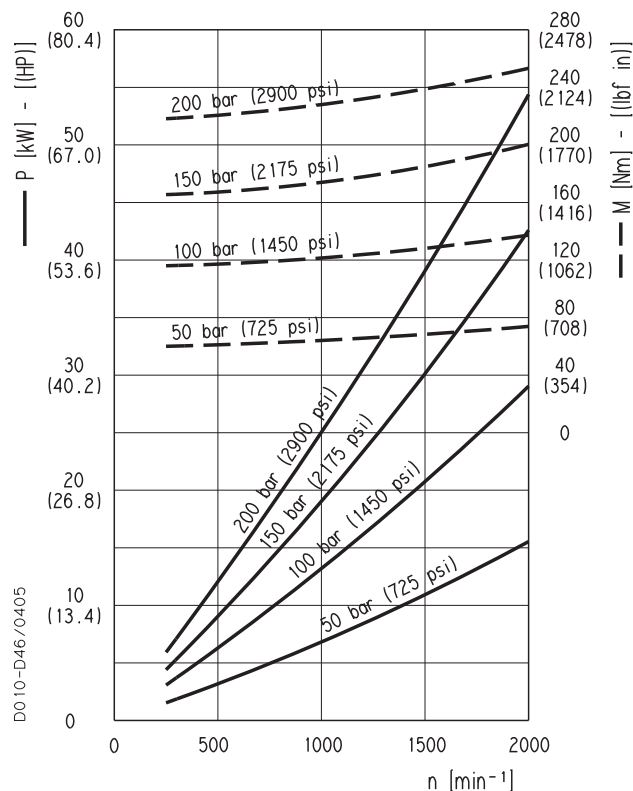

**HDP 30•73**

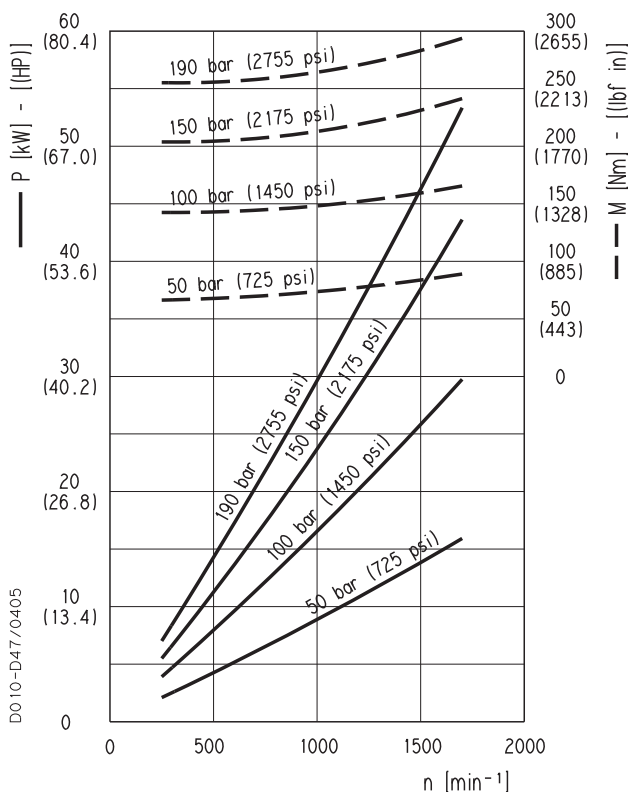

**HDP 30•82**

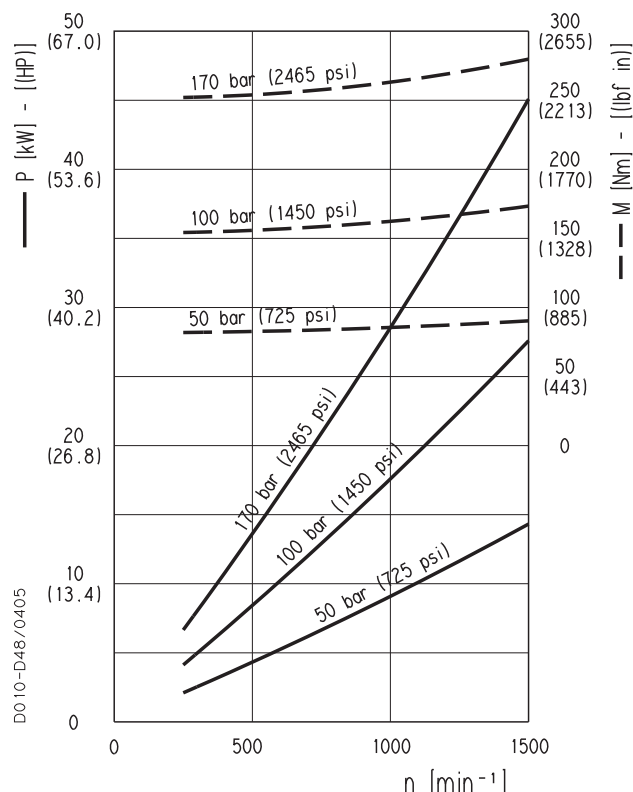

01/07.2005

**HDP 35**

**MAGNUM 35 GEAR PUMPS PERFORMANCE CURVES**

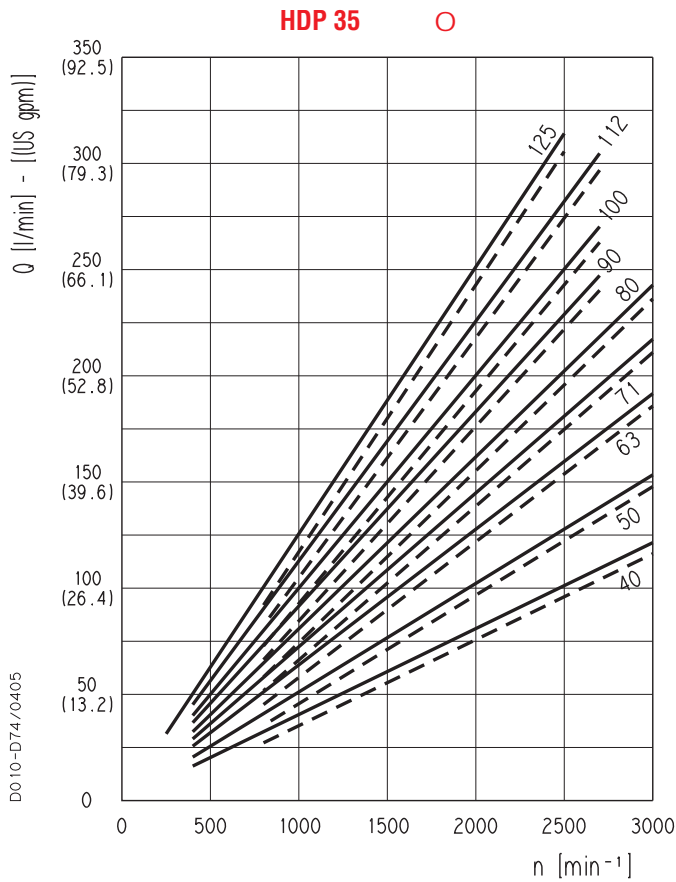

Each curve has been obtained at 122 °F (50°C), using oil with viscosity 168 SSU (36 cSt) at 104 °F (40°C) and at these pressures:

<b>HDP 35•50</b>	—	290 psi (20 bar)
	- -	3915 psi (270 bar)
<b>HDP 35•63</b>	—	290 psi (20 bar)
	- -	3915 psi (270 bar)
<b>HDP 35•71</b>	—	290 psi (20 bar)
	- -	3625 psi (250 bar)
<b>HDP 35•80</b>	—	290 psi (20 bar)
	- -	3625 psi (250 bar)
<b>HDP 35•90</b>	—	290 psi (20 bar)
	- -	3335 psi (230 bar)
<b>HDP 35•100</b>	—	290 psi (20 bar)
	- -	3045 psi (210 bar)
<b>HDP 35•112</b>	—	290 psi (20 bar)
	- -	2755 psi (190 bar)
<b>HDP 35•125</b>	—	290 psi (20 bar)
	- -	2465 psi (170 bar)

**New displacements**

<b>HDP 35•40</b>	290 - 3045 psi (20 - 270 bar)
------------------	----------------------------------

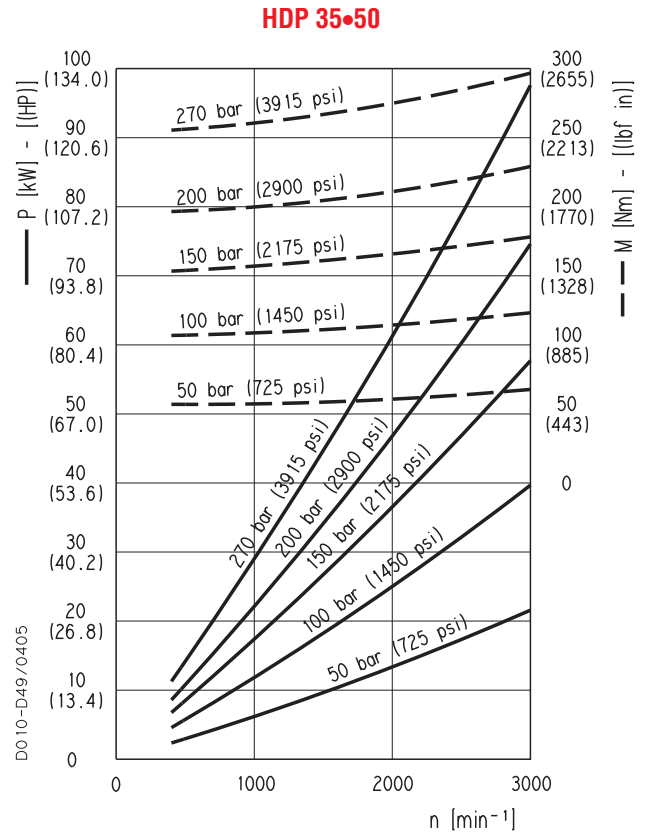
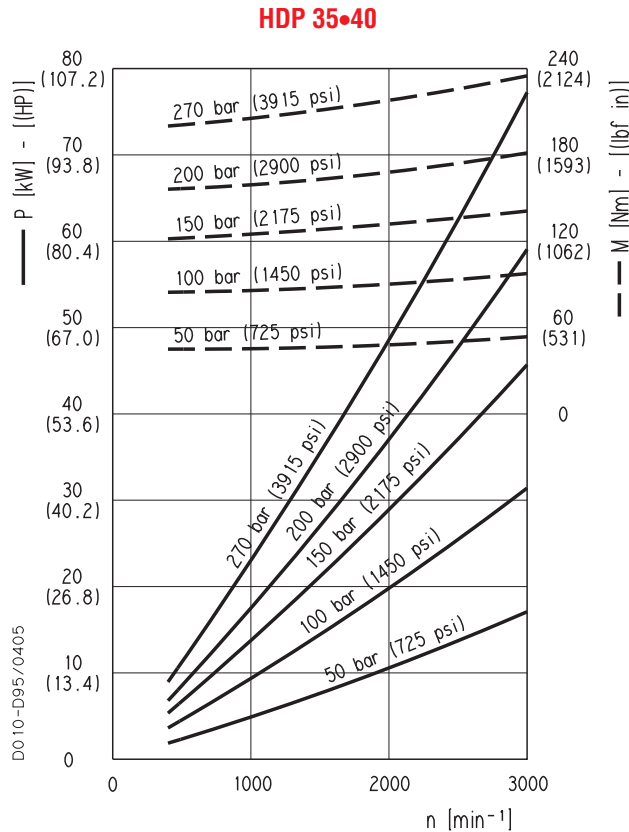

Replaces: 01/07.2005

○ 02/06.2012

**HDP 35**

**MAGNUM 35 GEAR PUMPS PERFORMANCE CURVES**

**HDP 35•63**

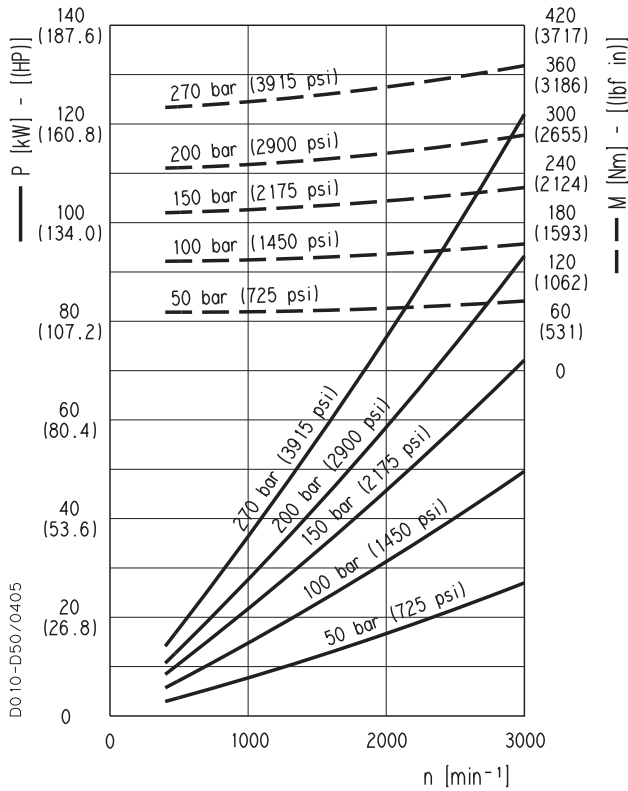

**HDP 35•71**

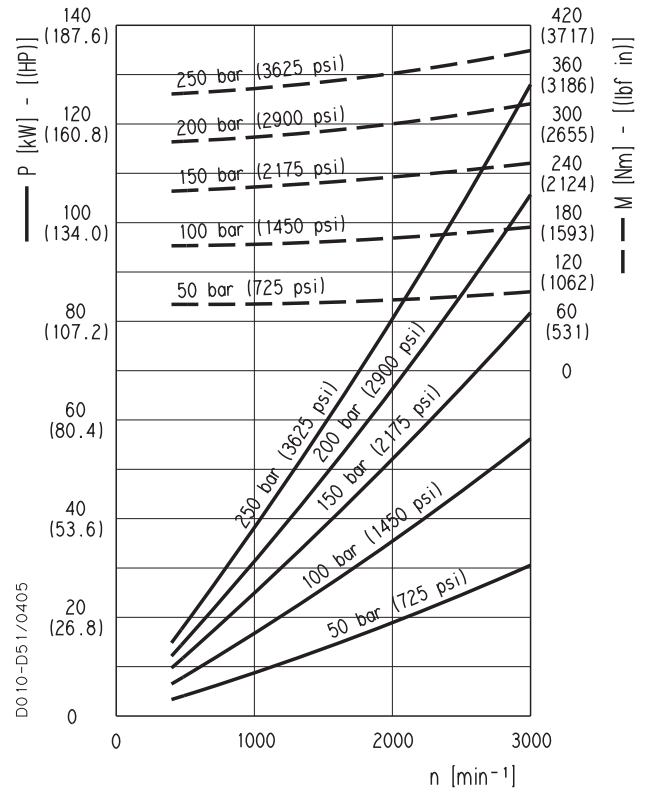

**HDP 35•80**

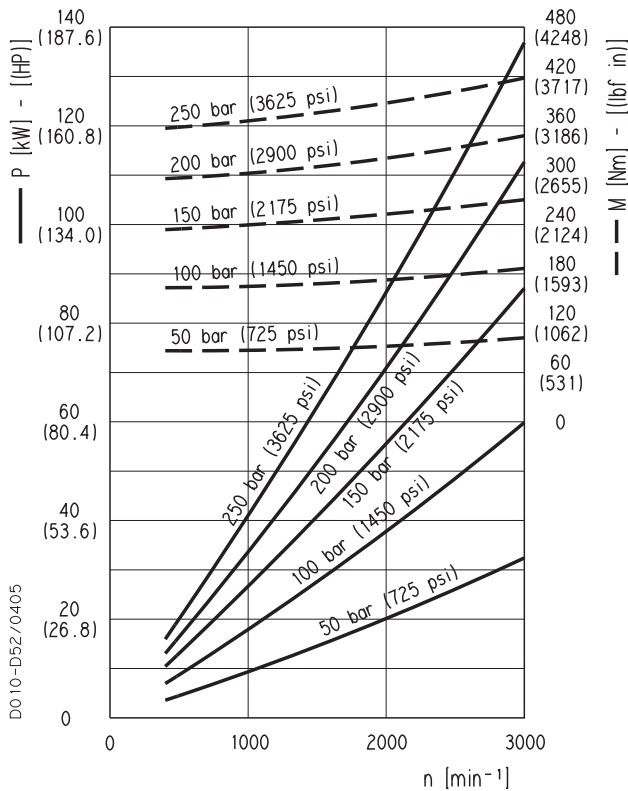

**HDP 35•90**

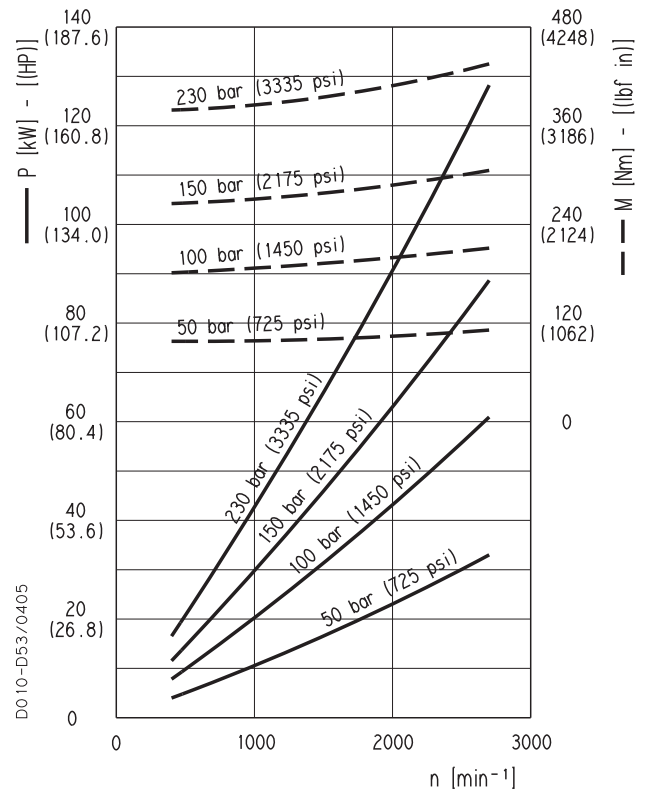

01/07.2005

**HDP 35**

**MAGNUM 35 GEAR PUMPS PERFORMANCE CURVES**

**HDP 35•100**

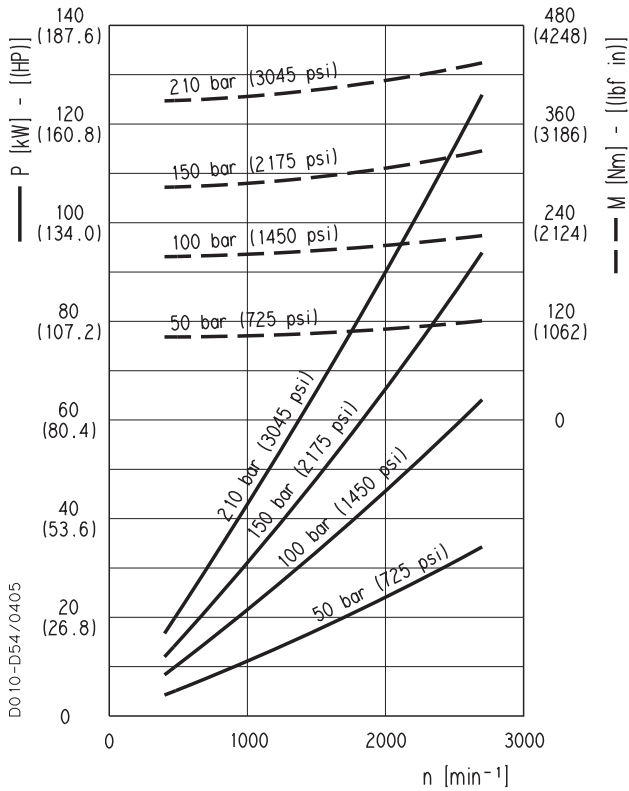

**HDP 35•112**

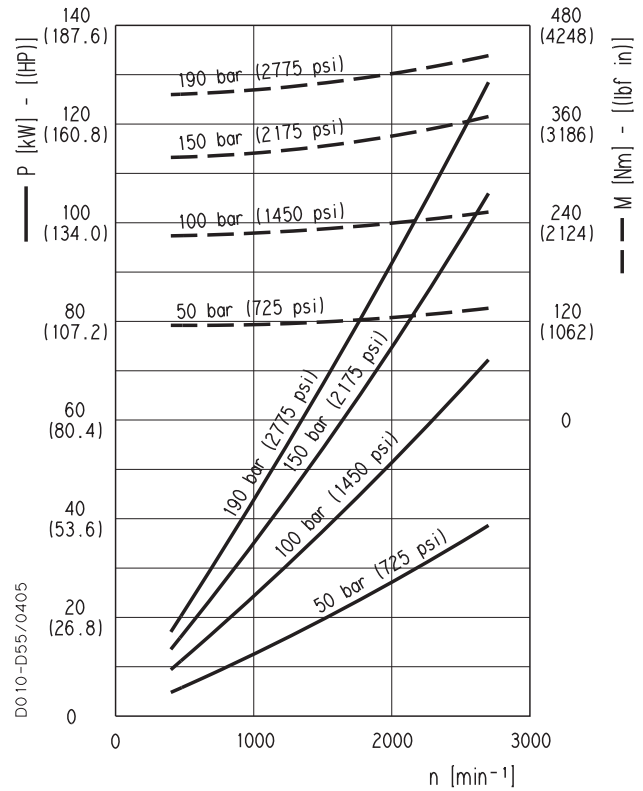

**HDP 35•125**

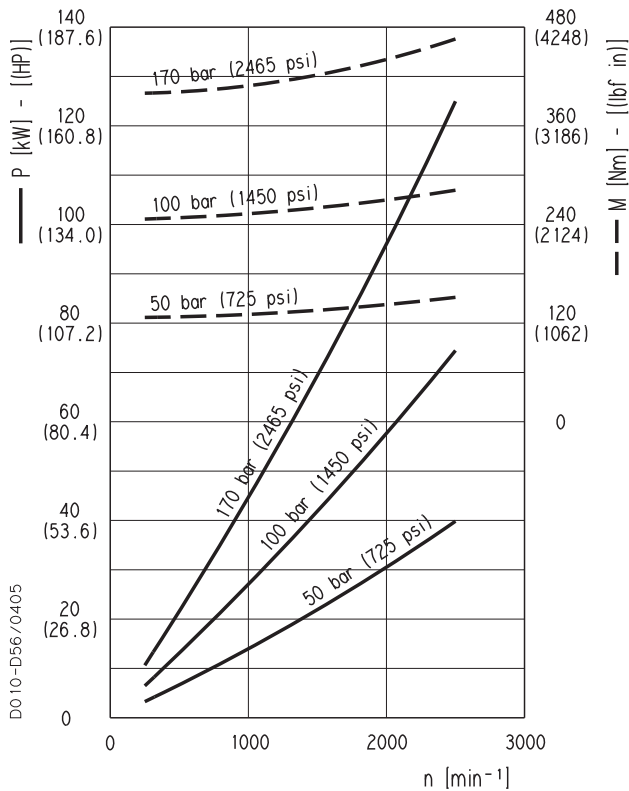

01/07.2005

**HDM 30**

**MAGNUM 30 GEAR MOTORS PERFORMANCE CURVES**

Replaces: 01/07.2005

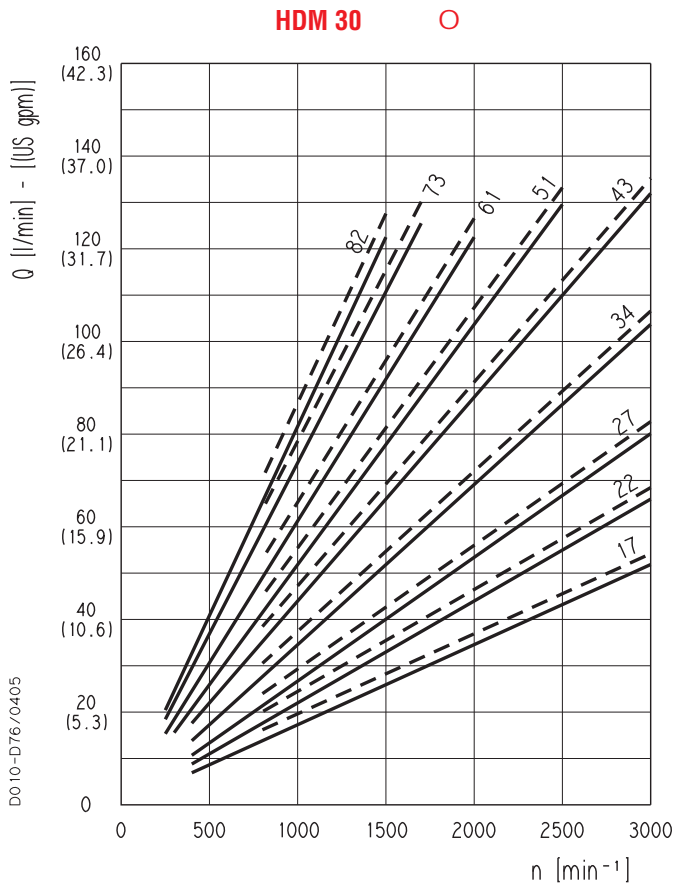

Each curve has been obtained at 122 °F (50°C), using oil with viscosity 168 SSU (36 cSt) at 104 °F (40°C) and at these pressures:

<b>HDP 30•17</b>	—	290 psi (20 bar)
	- -	4060 psi (280 bar)
<b>HDP 30•22</b>	—	290 psi (20 bar)
	- -	4060 psi (280 bar)
<b>HDP 30•27</b>	—	290 psi (20 bar)
	- -	4060 psi (280 bar)
<b>HDP 30•34</b>	—	290 psi (20 bar)
	- -	3915 psi (270 bar)
<b>HDP 30•43</b>	—	290 psi (20 bar)
	- -	3770 psi (260 bar)
<b>HDP 30•51</b>	—	290 psi (20 bar)
	- -	3335 psi (230 bar)
<b>HDP 30•61</b>	—	290 psi (20 bar)
	- -	2900 psi (200 bar)
<b>HDP 30•73</b>	—	290 psi (20 bar)
	- -	2755 psi (190 bar)
<b>HDP 30•82</b>	—	290 psi (20 bar)
	- -	2465 psi (170 bar)

○ 02/06.2012

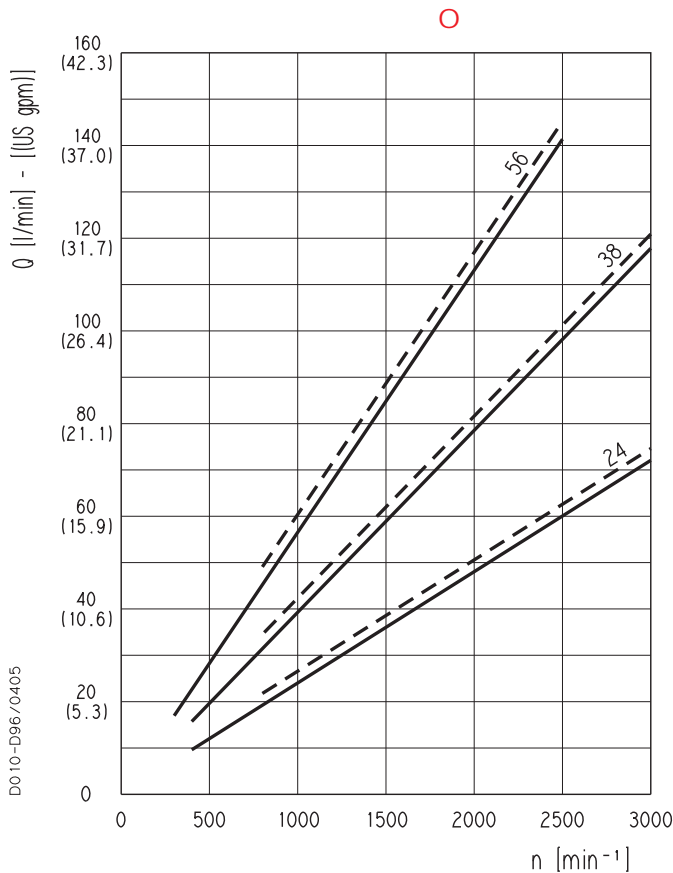

**New displacements**

<b>HDP 30•24</b>	—	290 psi (20 bar)
	- -	4060 psi (280 bar)
<b>HDP 30•38</b>	—	290 psi (20 bar)
	- -	3915 psi (270 bar)
<b>HDP 30•56</b>	—	290 psi (20 bar)
	- -	3118 psi (215 bar)

**HDM 30**

**MAGNUM 30 GEAR MOTORS PERFORMANCE CURVES**

**HDM 30•17**

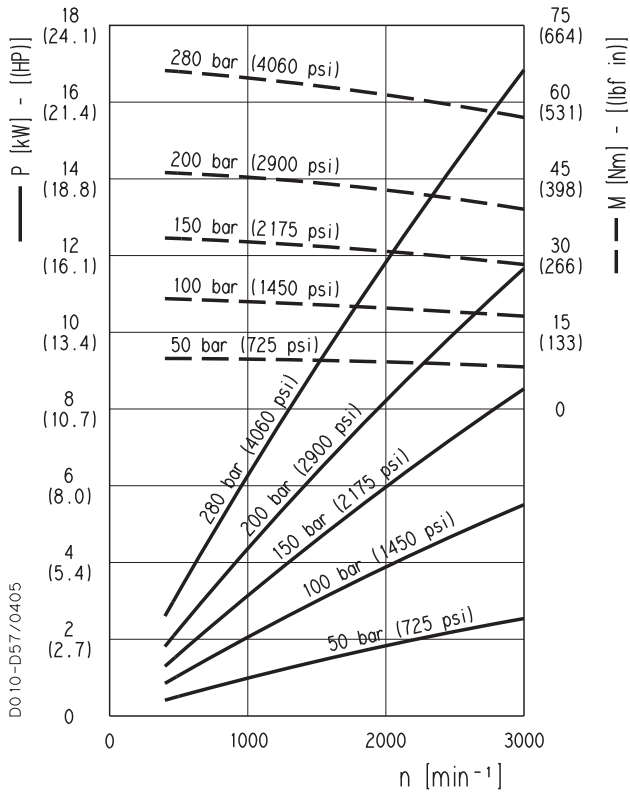

**HDM 30•22**

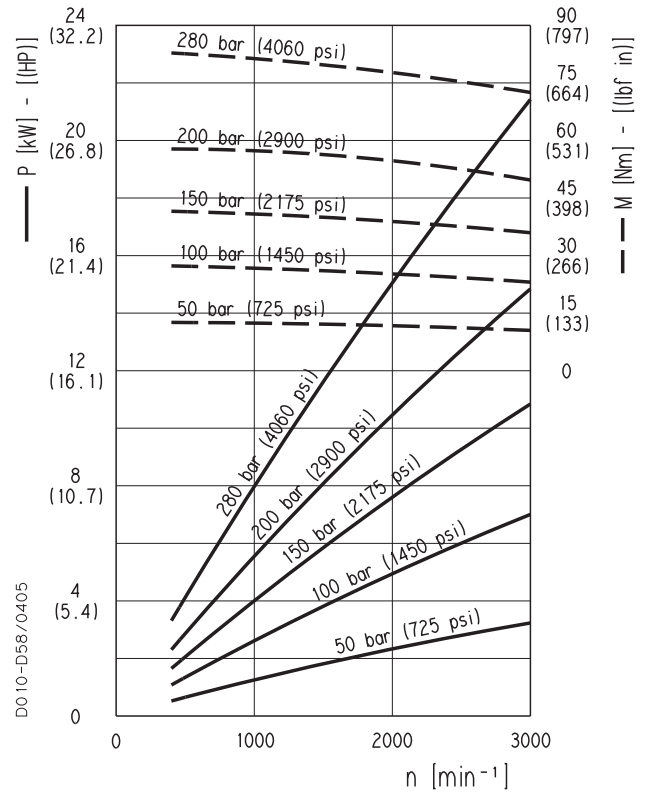

**HDM 30•24**

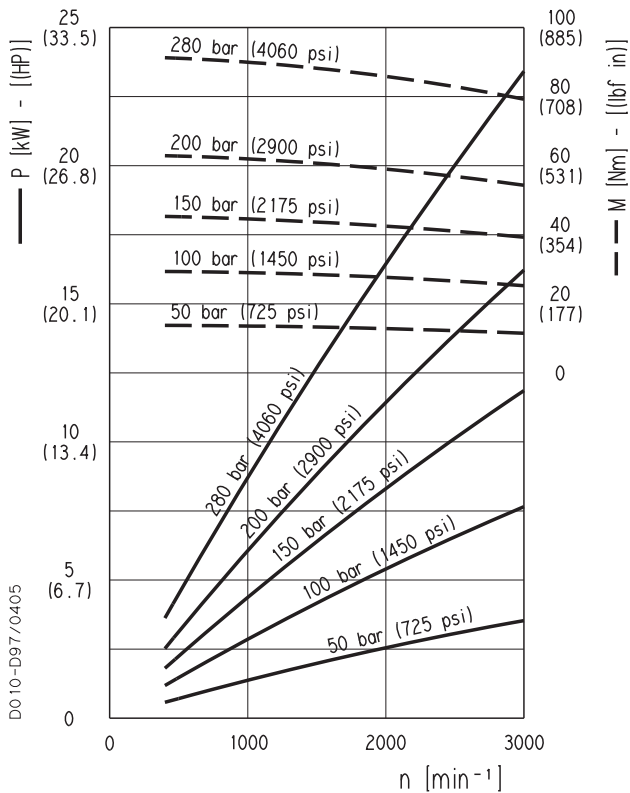

**HDM 30•27**

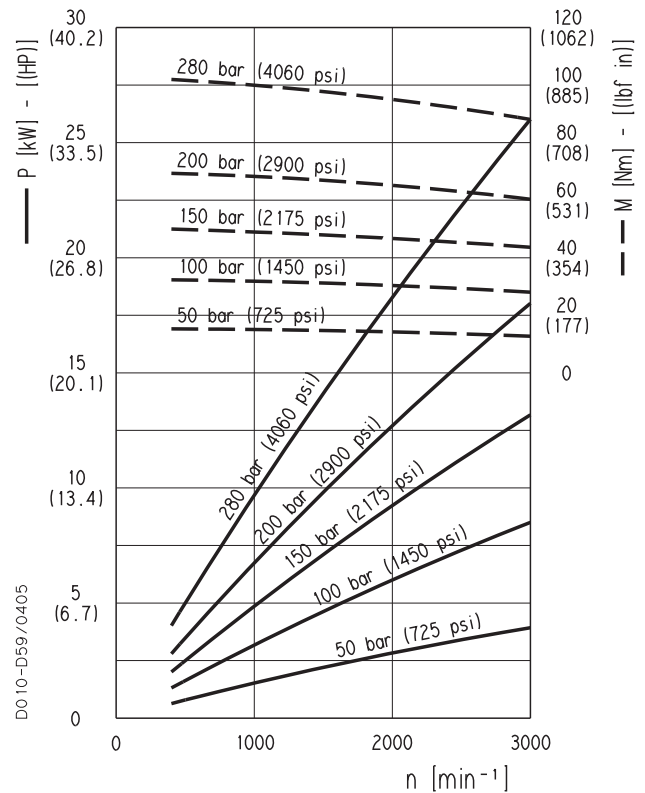

01/07.2005

**HDM 30**

**MAGNUM 30 GEAR MOTORS PERFORMANCE CURVES**

**HDM 30•34**

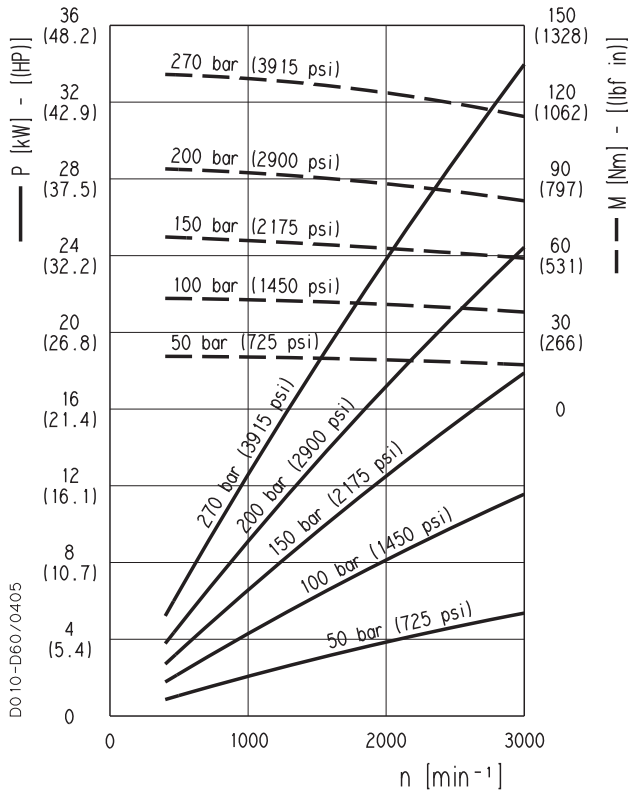

**HDM 30•38**

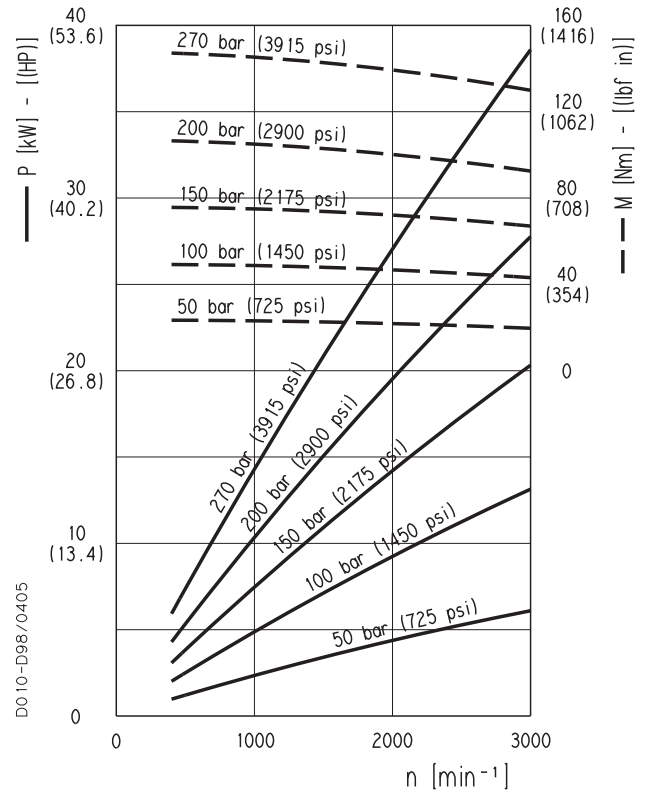

**HDM 30•43**

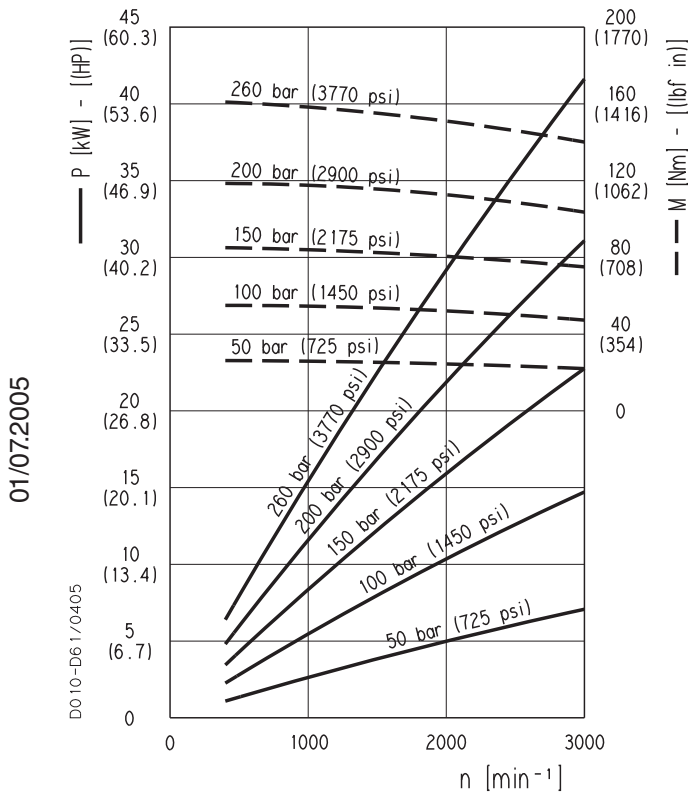

**HDM 30•51**

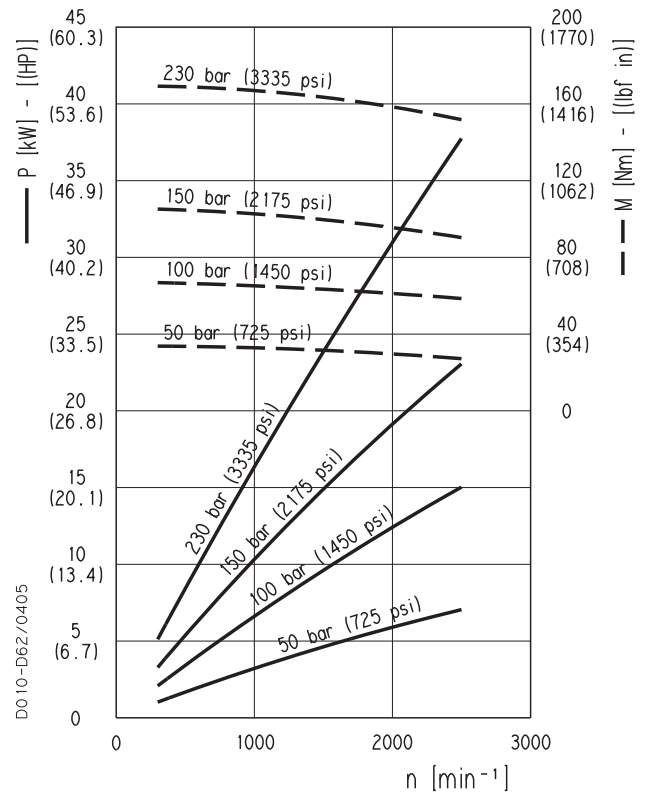

**HDM 30**

**MAGNUM 30 GEAR MOTORS PERFORMANCE CURVES**

**HDM 30•56**

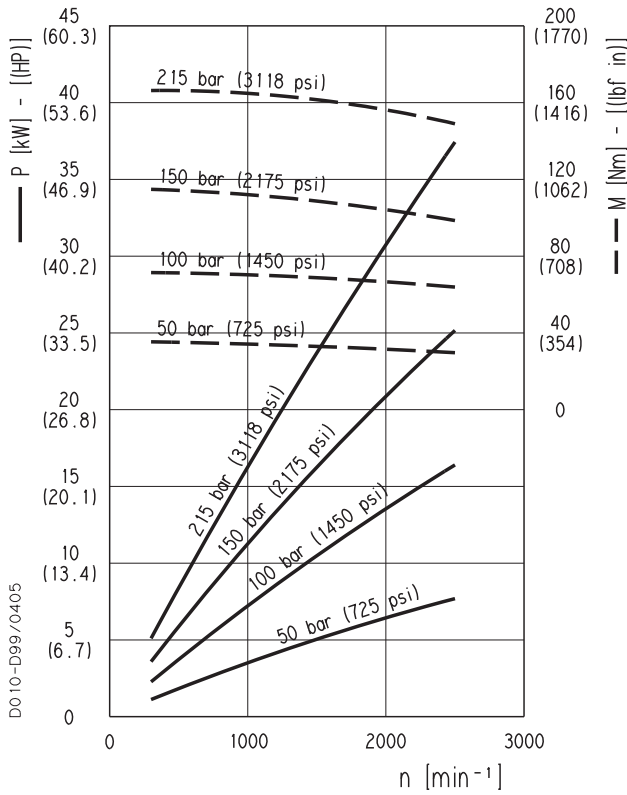

**HDM 30•61**

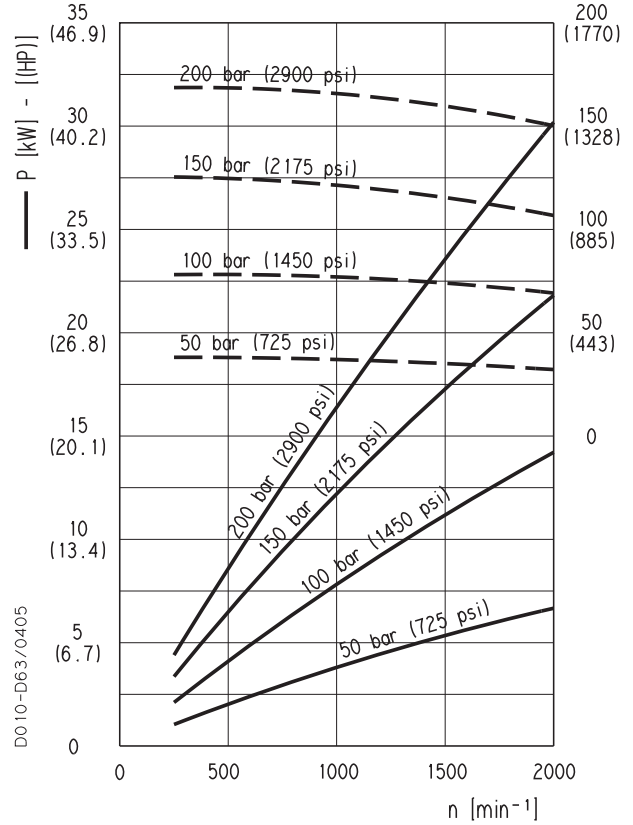

**HDM 30•73**

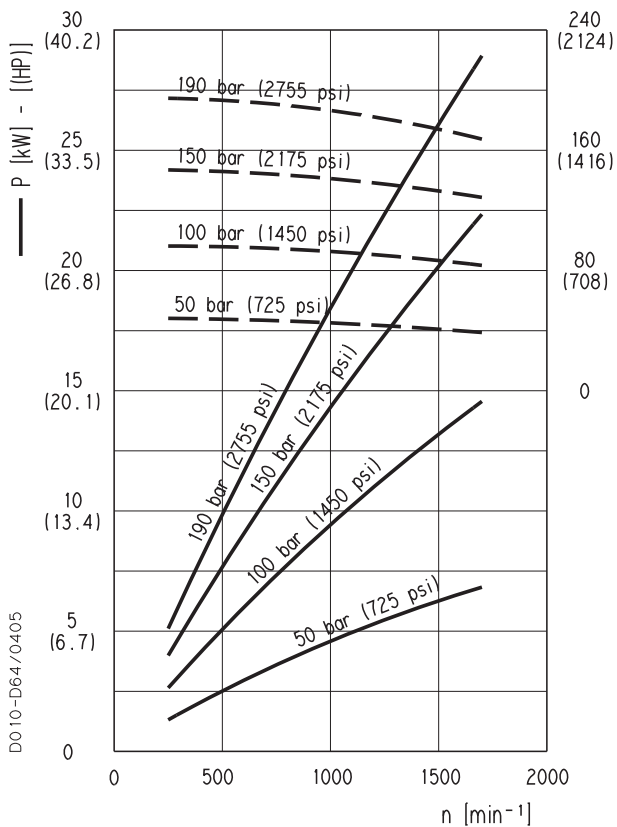

**HDM 30•82**

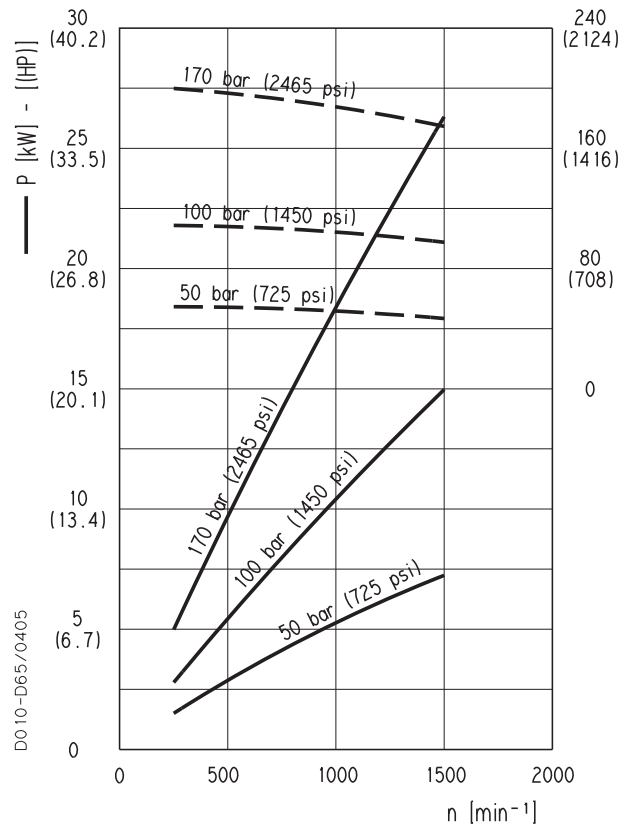

01/07.2005

**HDM 35**

**MAGNUM 35 GEAR MOTORS PERFORMANCE CURVES**

Replaces: 01/07.2005

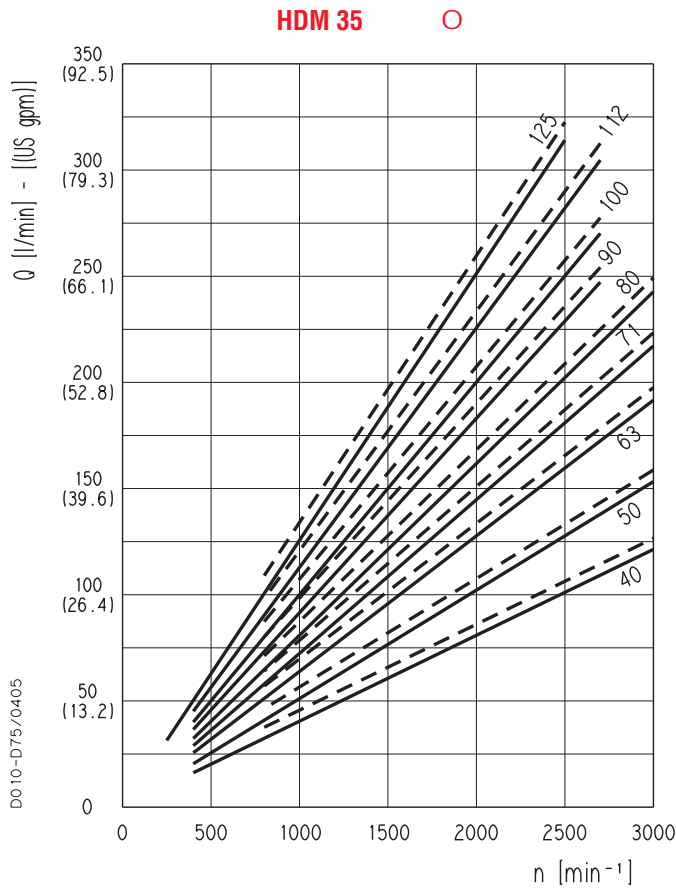

○ 02/06.2012

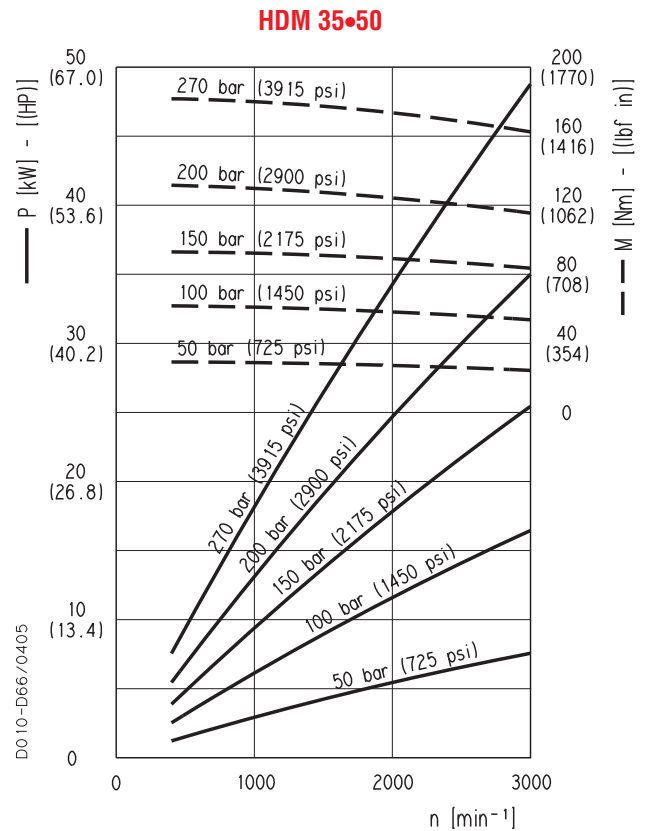
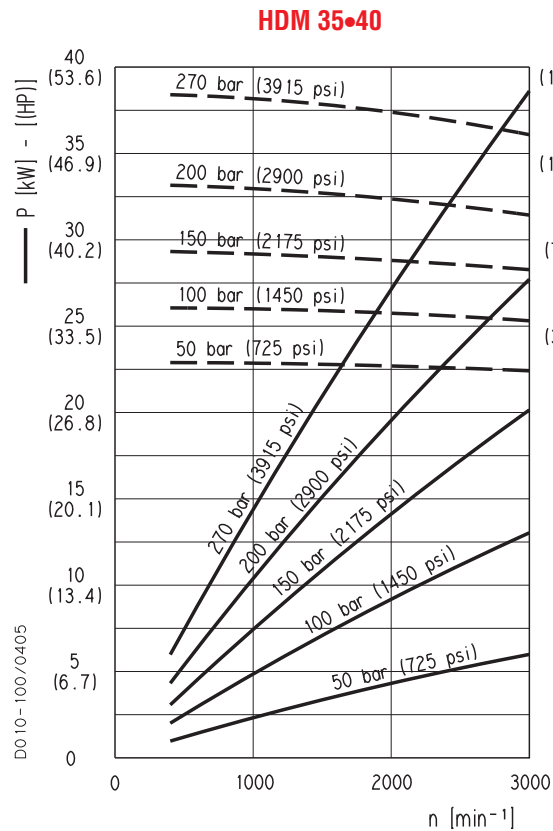

**HDM 35**

**MAGNUM 35 GEAR MOTORS PERFORMANCE CURVES**

**HDM 35•63**

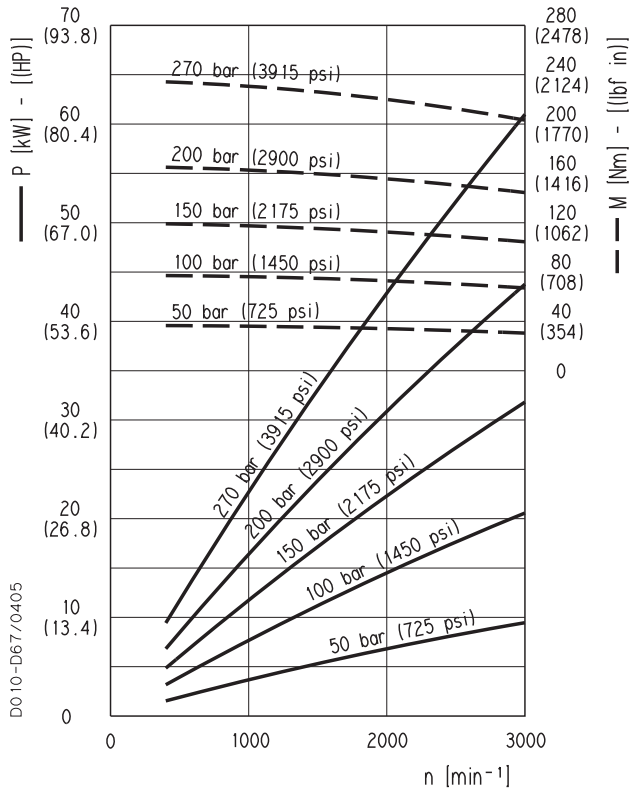

**HDM 35•71**

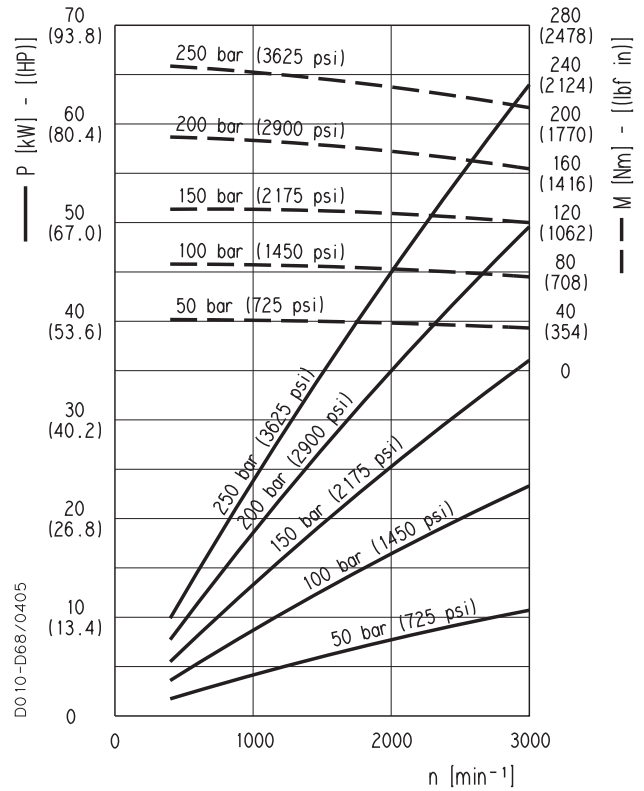

**HDM 35•80**

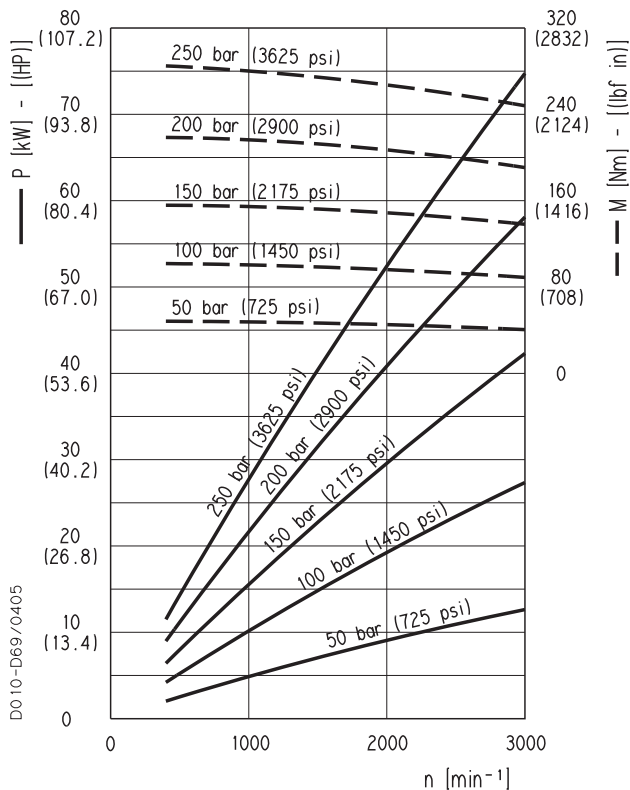

**HDM 35•90**

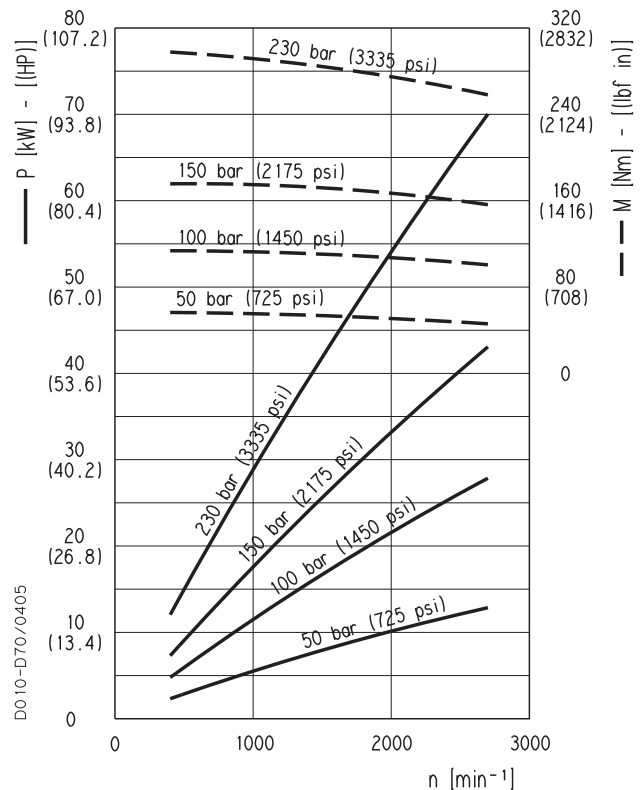

01/07.2005

**HDM 35**

**MAGNUM 35 GEAR MOTORS PERFORMANCE CURVES**

**HDM 35•100**

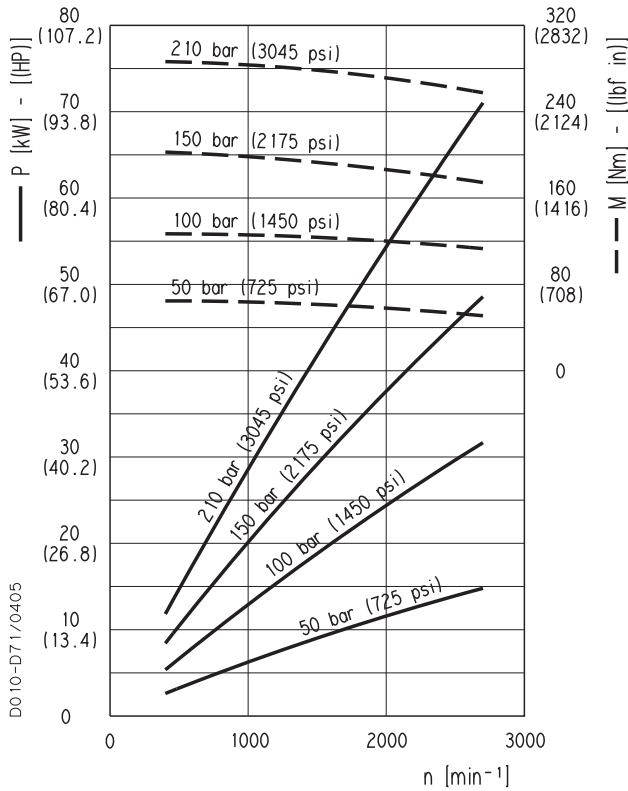

**HDM 35•112**

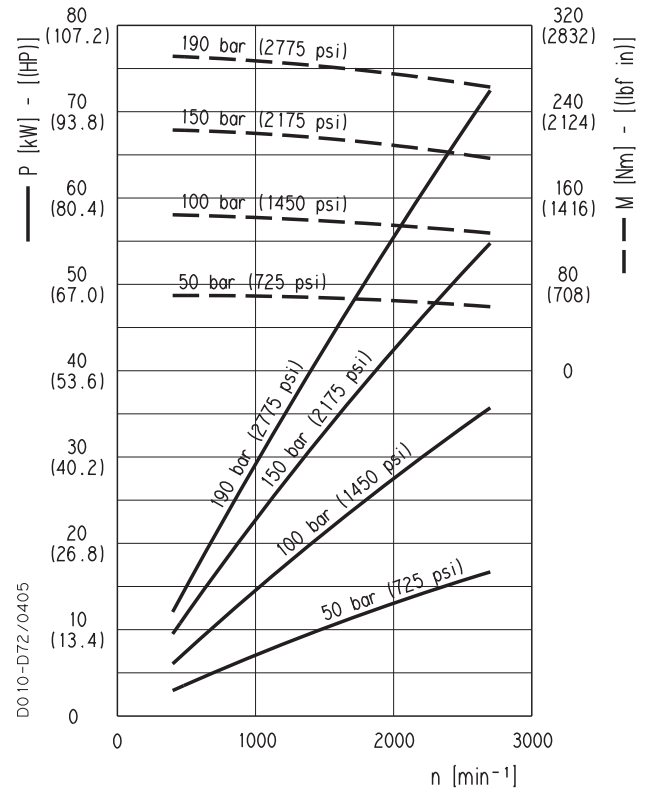

**HDM 35•125**

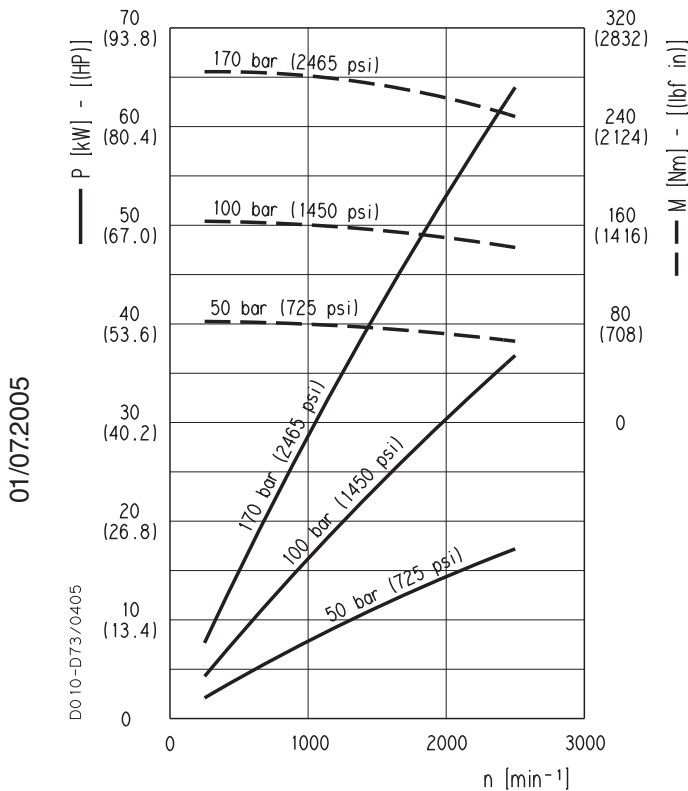

01/07.2005

**SINGLE UNITS SIDE PORTS**

**L**

D010-D01/0405

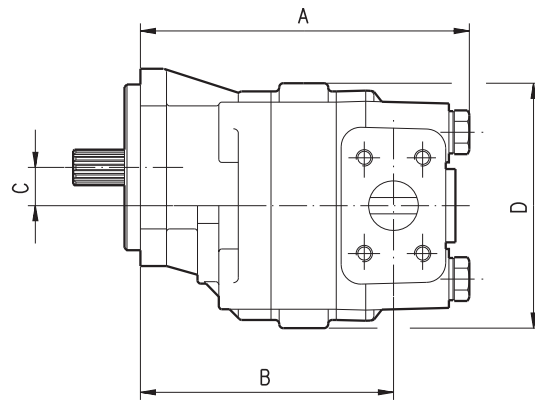
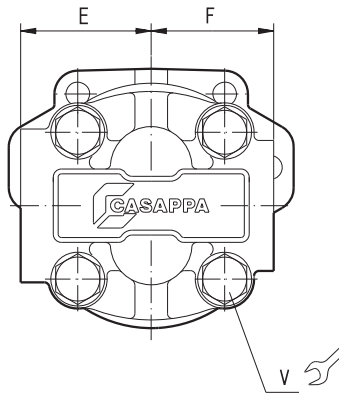

Tightening torque  
Nm (lbf in)

**V**

280 ±28 (2230 ÷ 2726)

DRIVE SHAFTS:  
see page 47

MOUNTING FLANGE:  
see page 48 ÷ 50

PORTS:  
see page 51

The drawing shows a single unit with left rotation.

Pump type Motor type	<b>A</b> mm (inch)	<b>B</b> mm (inch)	<b>C</b> mm (inch)	<b>D</b> mm (inch)	<b>E (IN)</b> mm (inch)	<b>F (OUT)</b> mm (inch)
<b>HD. 30•17</b>	184,5 (7.2638)	138 (5.4331)				
<b>HD. 30•22</b>	187,5 (7.3819)	141 (5.5512)				
<b>HD. 30•24</b>	188,8 (7.4331)	142,3 (5.6024)				
<b>HD. 30•27</b>	190,5 (7.5000)	144 (5.6693)				
<b>HD. 30•34</b>	195,5 (7.6969)	149 (5.8661)				
<b>HD. 30•38</b>	198,5 (7.8150)	152 (5.9843)	23,45 (0.9232)	150 (5.9055)	80 (3.1496)	75 (2.9528)
<b>HD. 30•43</b>	201,5 (7.9331)	155 (6.1024)				
<b>HD. 30•51</b>	206,5 (8.1299)	160 (6.2992)				
<b>HD. 30•56</b>	209,5 (8.2480)	163 (6.4173)				
<b>HD. 30•61</b>	212,5 (8.3661)	166 (6.5354)				
<b>HD. 30•73</b>	220,5 (8.6811)	174 (6.8504)				
<b>HD. 30•82</b>	225,5 (8.8780)	179 (7.0472)				
<b>HD. 35•40</b>	224,5 (8.8386)	172 (6.7717)				
<b>HD. 35•50</b>	229,5 (9.0354)	177 (6.9685)				
<b>HD. 35•63</b>	235,5 (9.2717)	183 (7.2047)				
<b>HD. 35•71</b>	239,5 (9.4291)	187 (7.3622)				
<b>HD. 35•80</b>	243,5 (9.5866)	191 (7.5197)	27,35 (1.0768)	172 (6.7717)	90 (3.5433)	85 (3.3465)
<b>HD. 35•90</b>	248,5 (9.7835)	196 (7.7165)				
<b>HD. 35•100</b>	252,5 (9.9409)	200 (7.8740)				
<b>HD. 35•112</b>	258,5 (10.1772)	206 (8.1102)				
<b>HD. 35•125</b>	264,5 (10.4134)	212 (8.3465)				

01/07.2005

**SINGLE UNITS REAR PORTS**

**P**

D010-D81/0405

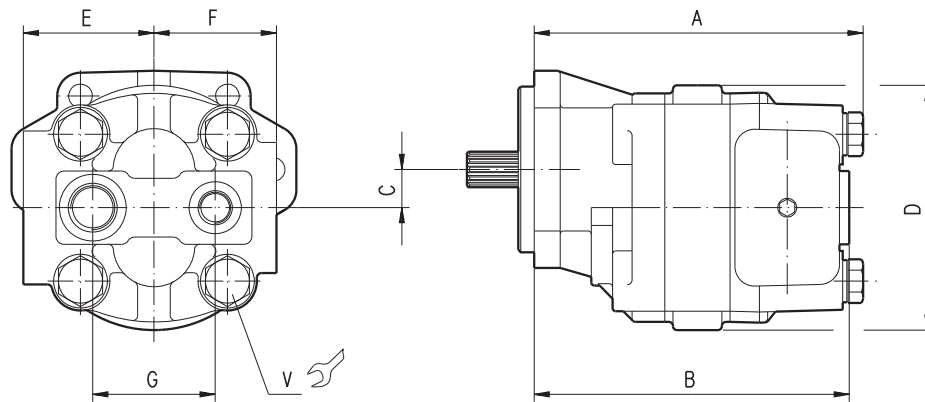

Tightening torque  
Nm (lbf in)

**V**

280 ±28 (2230 ÷ 2726)

DRIVE SHAFTS:  
see page 47

MOUNTING FLANGE:  
see page 48 ÷ 50

PORTS:  
see page 51

The drawing shows a single unit with left rotation.

01/07.2005

Pump type Motor type	A	B	C	D	E	F	G
	mm (inch)	mm (inch)	mm (inch)	mm (inch)	mm (inch)	mm (inch)	mm (inch)
<b>HD. 30•17</b>	184,5 (7.2638)	173 (6.8110)					
<b>HD. 30•22</b>	187,5 (7.3819)	176 (6.9291)					
<b>HD. 30•24</b>	188,8 (7.4331)	177,3 (6.9803)					
<b>HD. 30•27</b>	190,5 (7.5000)	179 (7.0472)					
<b>HD. 30•34</b>	195,5 (7.6969)	184 (7.2441)					
<b>HD. 30•38</b>	198,5 (7.8150)	187 (7.3622)	23,45 (0.9232)	150 (5.9055)	80 (3.1496)	75 (2.9528)	75 (2.9528)
<b>HD. 30•43</b>	201,5 (7.9331)	190 (7.4803)					
<b>HD. 30•51</b>	206,5 (8.1299)	195 (7.6772)					
<b>HD. 30•56</b>	209,5 (8.2480)	198 (7.7953)					
<b>HD. 30•61</b>	212,5 (8.3661)	201 (7.9134)					
<b>HD. 30•73</b>	220,5 (8.6811)	209 (8.2283)					
<b>HD. 30•82</b>	225,5 (8.8780)	214 (8.4252)					
<b>HD. 35•40</b>	224,5 (8.8386)	213 (8.3858)					
<b>HD. 35•50</b>	229,5 (9.0354)	218 (8.5827)					
<b>HD. 35•63</b>	235,5 (9.2717)	224 (8.8189)					
<b>HD. 35•71</b>	239,5 (9.4291)	228 (8.9764)					
<b>HD. 35•80</b>	243,5 (9.5866)	232 (9.1339)	27,35 (1.0768)	172 (6.7717)	90 (3.5433)	85 (3.3465)	89 (3.5039)
<b>HD. 35•90</b>	248,5 (9.7835)	237 (9.3307)					
<b>HD. 35•100</b>	252,5 (9.9409)	241 (9.4882)					
<b>HD. 35•112</b>	258,5 (10.1772)	247 (9.7244)					
<b>HD. 35•125</b>	264,5 (10.4134)	253 (9.9606)					

**MAGNUM 35 SINGLE PUMPS WITH LARGER REAR PORTS**

**P**

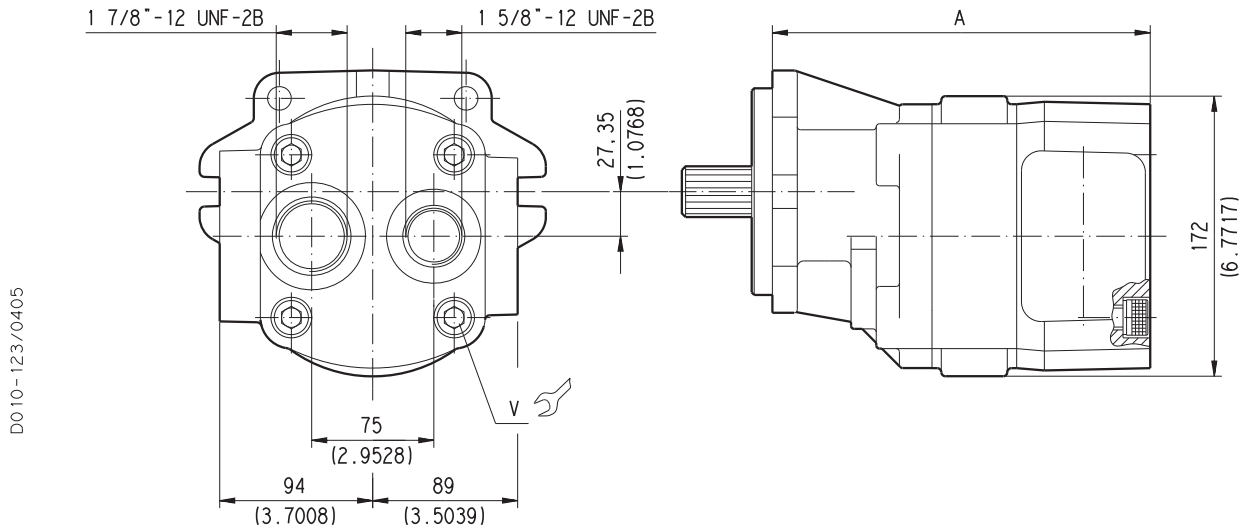

D010-123/0405

Tightening torque Nm (lbf in)
<b>V</b>
280 ±28 (2230 ÷ 2726)

DRIVE SHAFTS:  
see page 47

MOUNTING FLANGE:  
see page 48 ÷ 50

PORTS:  
see page 55

The drawing shows a single unit with left rotation.

01/07.2005

Pump type	A		Ports code (ODT)	
	mm (inch)		IN	OUT
<b>HDP 35•40</b>	213 (8.3858)			
<b>HDP 35•50</b>	218 (8.5827)			
<b>HDP 35•63</b>	224 (8.8190)		OH	OG
<b>HDP 35•71</b>	228 (8.9764)		(1 7/8" - 12 UNF - 2B)	(1 5/8" - 12 UNF - 2B)
<b>HDP 35•80</b>	232 (9.1339)			

## MULTIPLE PUMPS

MAGNUM series pumps can be coupled together in combination. Where input power requirement of each element varies, that with the greater requirement must be at the drive shaft end, and progressively smaller to the rear.

Features and performances are the same as the corresponding single pumps, but pressures must be limited by the transmissible torque of the drive and connecting shafts. To have appropriate data, use the formula below.

Replaces: 01/07.2005 The maximum rotational speed is that of the lowest rated speed of the single units incorporated.

Available with separated inlet, common inlet and separated stages.

Combination MAGNUM + KAPPA 20 series and MAGNUM + POLARIS 20 series are available with standard version and EM version with reduced dimensions for O.E.M.s.

For more information please consult our technical sales department.

For KAPPA 20 and POLARIS 20 series general data please consult the proper technical catalogues.

<b>M</b>	lbf in (Nm)	Torque
<b>V</b>	in <sup>3</sup> /rev (cm <sup>3</sup> /rev)	Displacement
<b>Δp</b>	psi (bar)	Pressure
$\eta_{hm} = \eta_{hm}(V, \Delta p, n)$	(≈ 0,90)	Hydro-mechanical efficiency

$$\begin{aligned}
 M &= \frac{M_{theor.}}{\eta_{hm}} \quad [Nm] \\
 M_{theor.} &= \frac{\Delta p \text{ (bar)} \cdot V \text{ (cm}^3\text{/rev)}}{62,83}
 \end{aligned}$$

**Note:** The torque absorbed from the shaft of the first pump results from the sum of the torques due to all single stages. The achieved value must not exceed the maximum torque limit given for the shaft of the first pump. Diagrams providing approximate selection data will be found on page 26.

○ 02/06.2012

## ABSORBED TORQUE

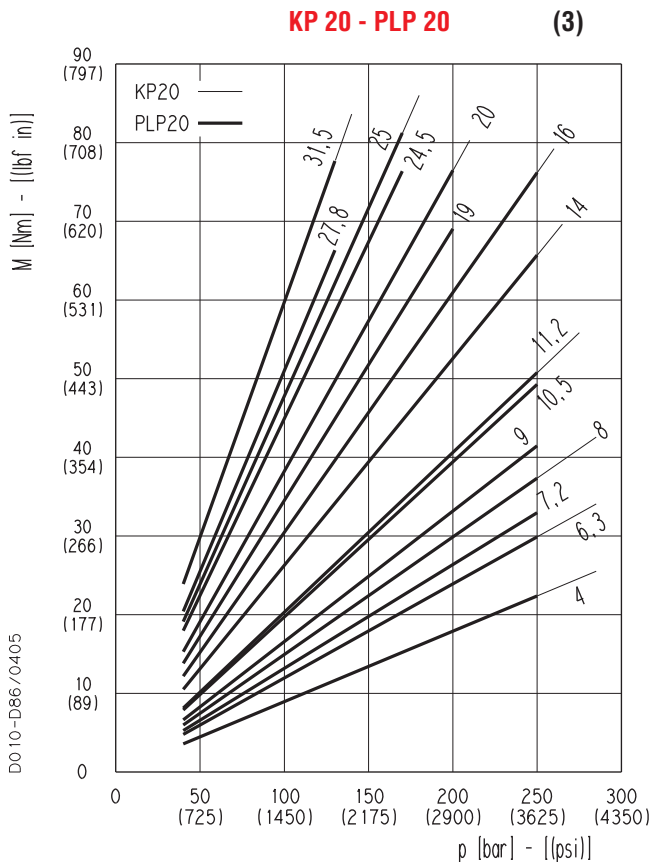
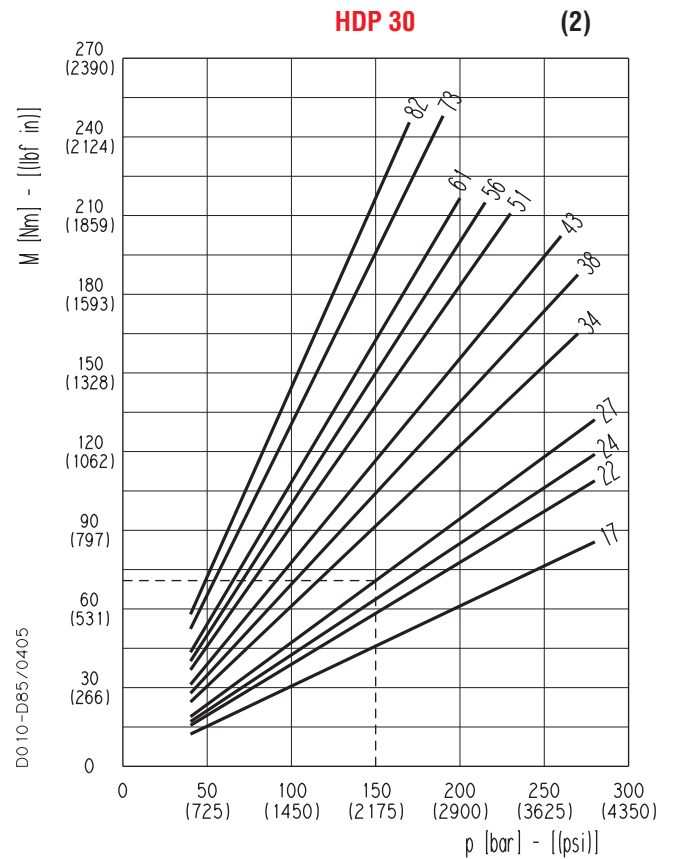
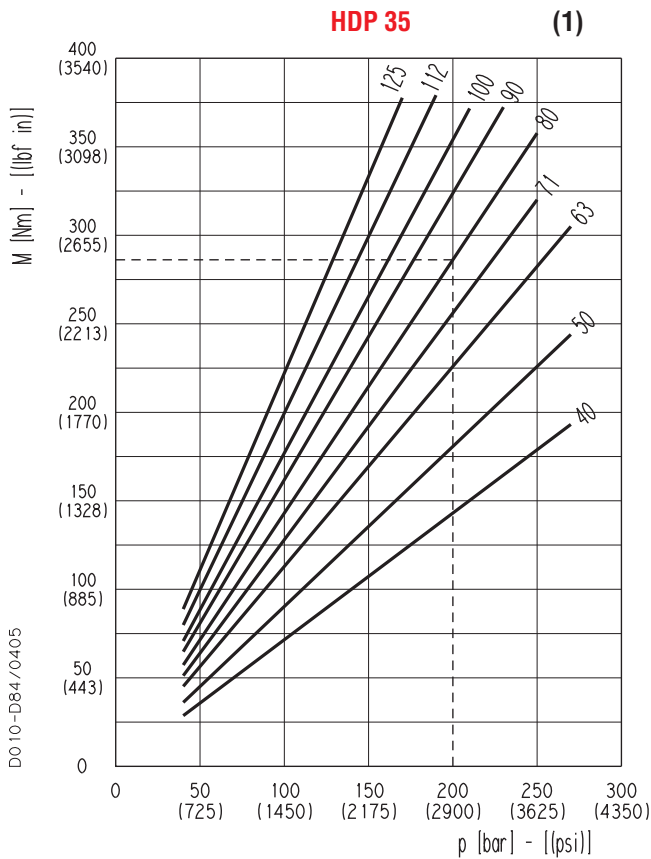

### DRIVE SHAFT SELECTION

Let us consider a double pump HDP35•80 + HDP30•27. If we suppose that we have to work with the first pump at a pressure of 2900 psi (200 bar) and the second pump at a pressure of 2175 psi (150 bar), the graph 1 shows that the torque absorbed by HDP35•80 is 2523 lbf in (285 Nm) and the graph 2 shows that the torque absorbed by HDP30•27 is 620 lbf in (70 Nm) acceptable value because it doesn't exceed the maximum connecting shaft torque that is 1505 lbf in (170 Nm), see page 27. The torque to be transmitted by the first drive shaft will thus be 2523+620= 3143 lbf in (285+70= 355 Nm), this value must not exceed the shaft's maximum rated value.

01/07.2005

## MULTIPLE PUMPS HDP.. / HDP..

### HDP 35/35

### STANDARD VERSION

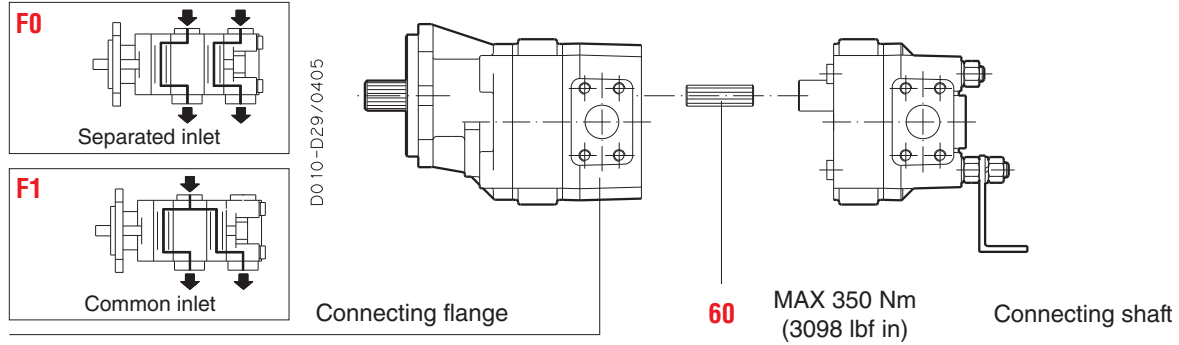

### HDP 35/30

### STANDARD VERSION

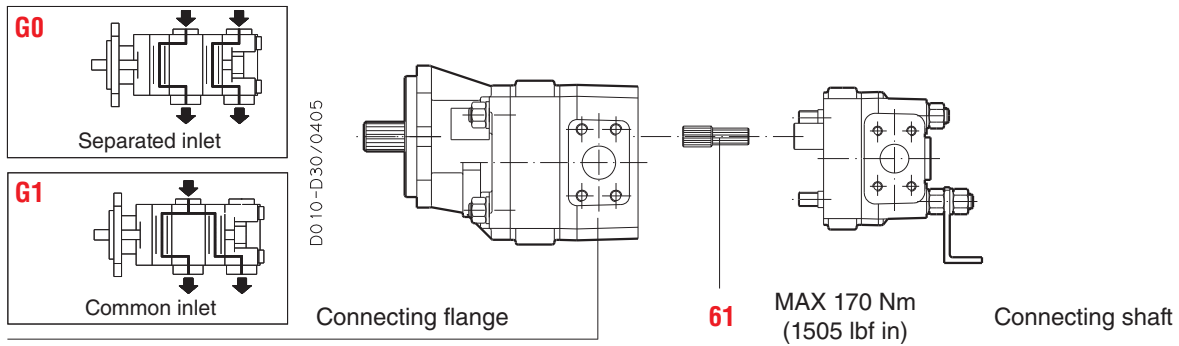

### HDP 30/30

### STANDARD VERSION

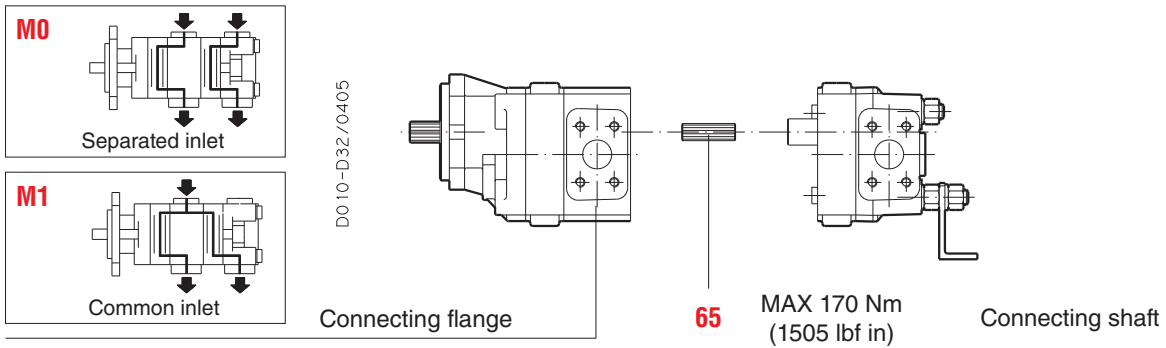

## REAR COVER CONNECTION

01/07:2005

All multiple pumps with more than two sections are available with bracket.

### SEPARATED INLET

Without bracket

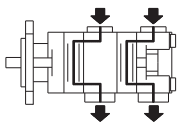

**0**

With bracket

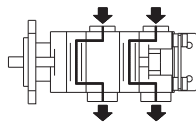

**9**

### COMMON INLET

Without bracket

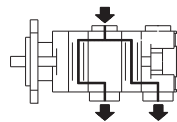

**1**

With bracket

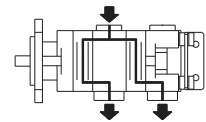

**8**

# DOUBLE PUMPS HDP35 / KP20

## STANDARD VERSION

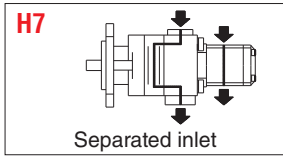

D010-D31/0405

Connecting flange

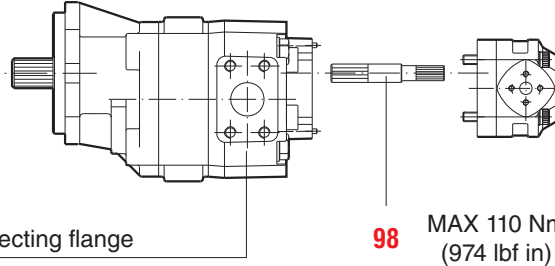

KP20•.... - **N6**

Connecting shaft

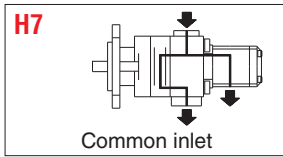

D010-111/0405

Connecting flange

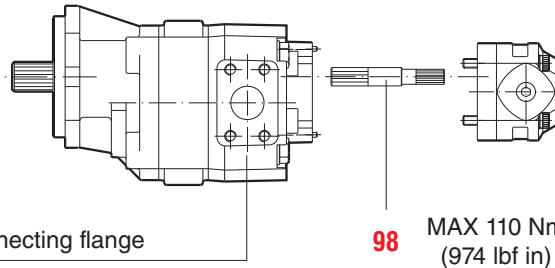

KP20•.... - **N7**

Connecting shaft

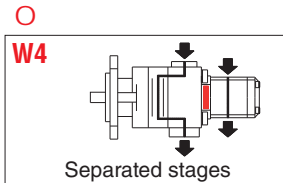

D010-112/0405

Connecting flange

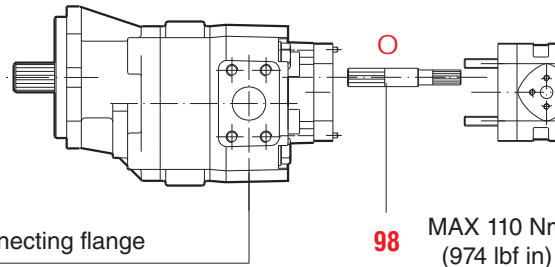

KP20•.... - **Z6**

Connecting shaft

## EM VERSION

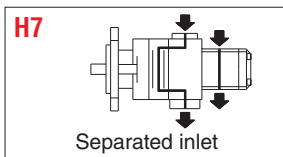

D010-108/0405

Connecting flange

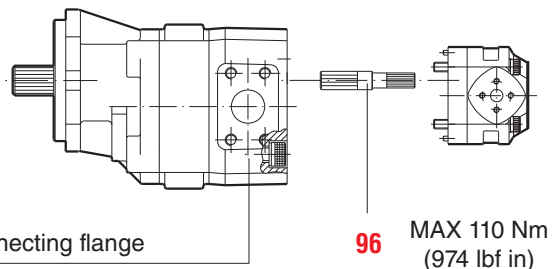

KP20•.... - **N6** / **EM**

Connecting shaft

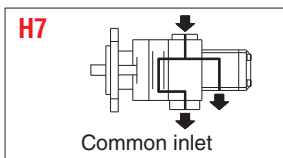

D010-113/0405

Connecting flange

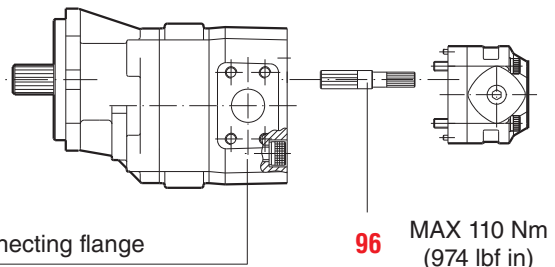

KP20•.... - **N7** / **EM**

Connecting shaft

Replaces: 01/07.2005

02/06.2012

## DOUBLE PUMPS HDP35 / PLP20

### STANDARD VERSION

Replaces: 01/07.2005

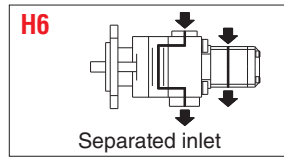

D010-106/0405

Connecting flange

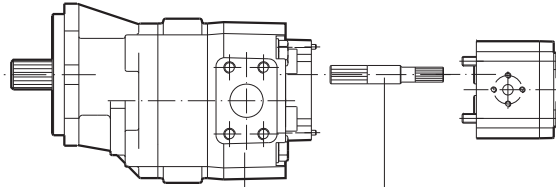

**98** MAX 110 Nm  
(974 lbf in)

Connecting shaft

PLP20•... - **H6**

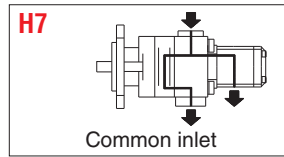

D010-114/0405

Connecting flange

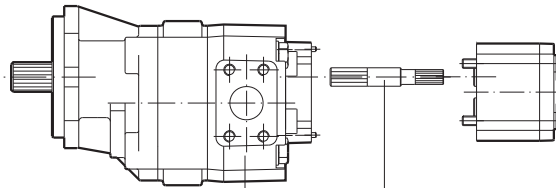

**98** MAX 110 Nm  
(974 lbf in)

Connecting shaft

PLP20•... - **H7**

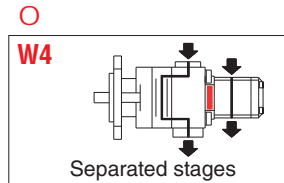

D010-115/0405

Connecting flange

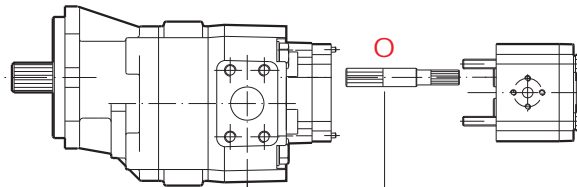

**98** MAX 110 Nm  
(974 lbf in)

Connecting shaft

PLP20•... - **Z6** ○

### EM VERSION

○ 02/06.2012

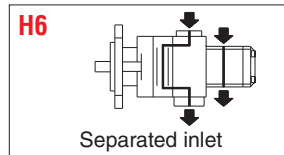

D010-107/0405

Connecting flange

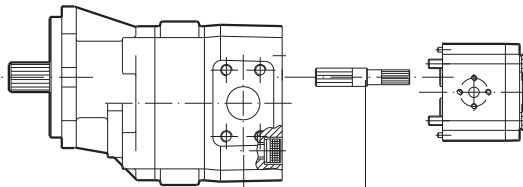

**96** MAX 110 Nm  
(974 lbf in)

Connecting shaft

PLP20•... - **H6** / **EM**

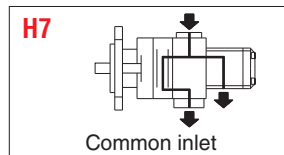

D010-116/0405

Connecting flange

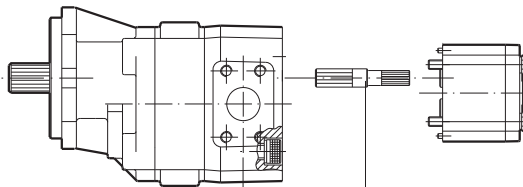

**96** MAX 110 Nm  
(974 lbf in)

Connecting shaft

PLP20•... - **H7** / **EM**

## DOUBLE PUMPS HDP30 / KP20

### STANDARD VERSION

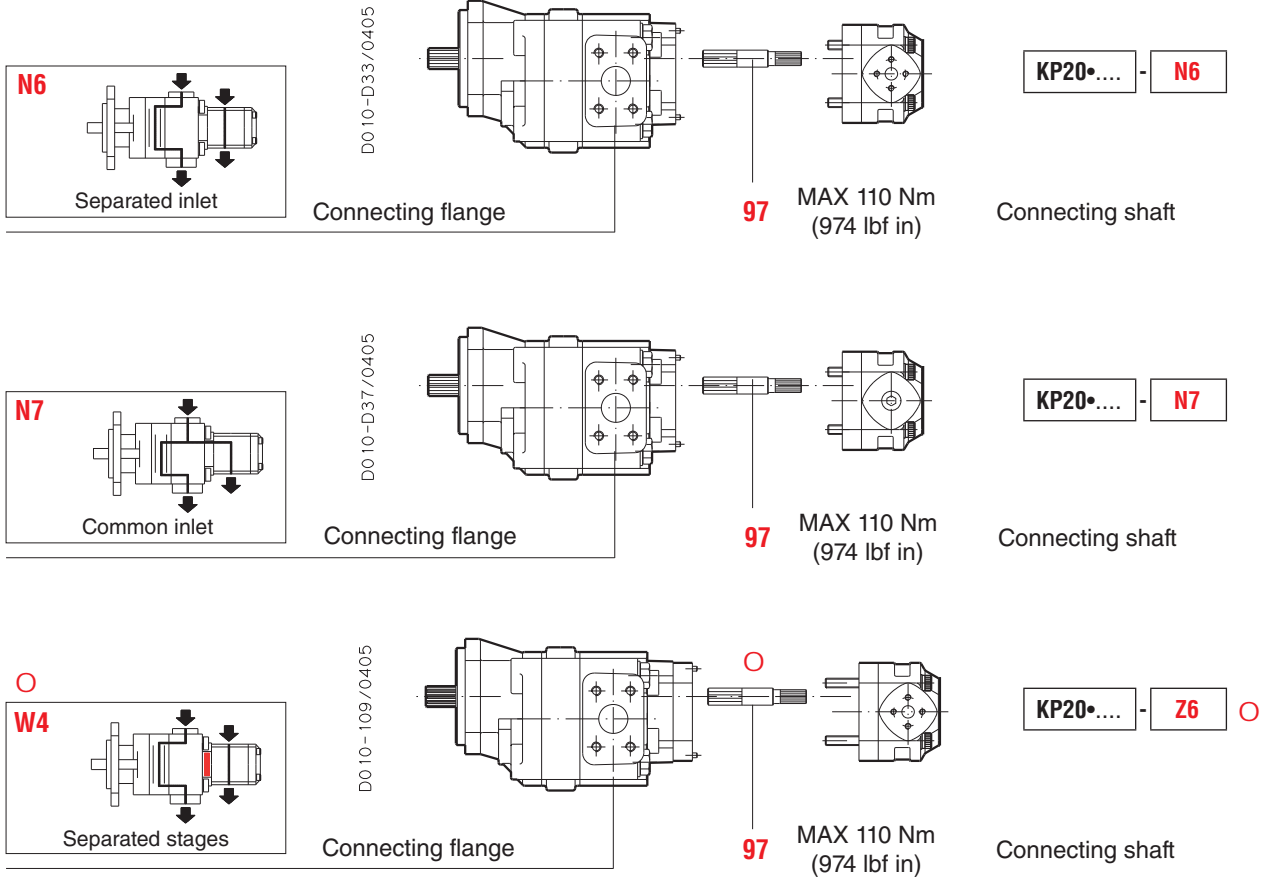

### EM VERSION

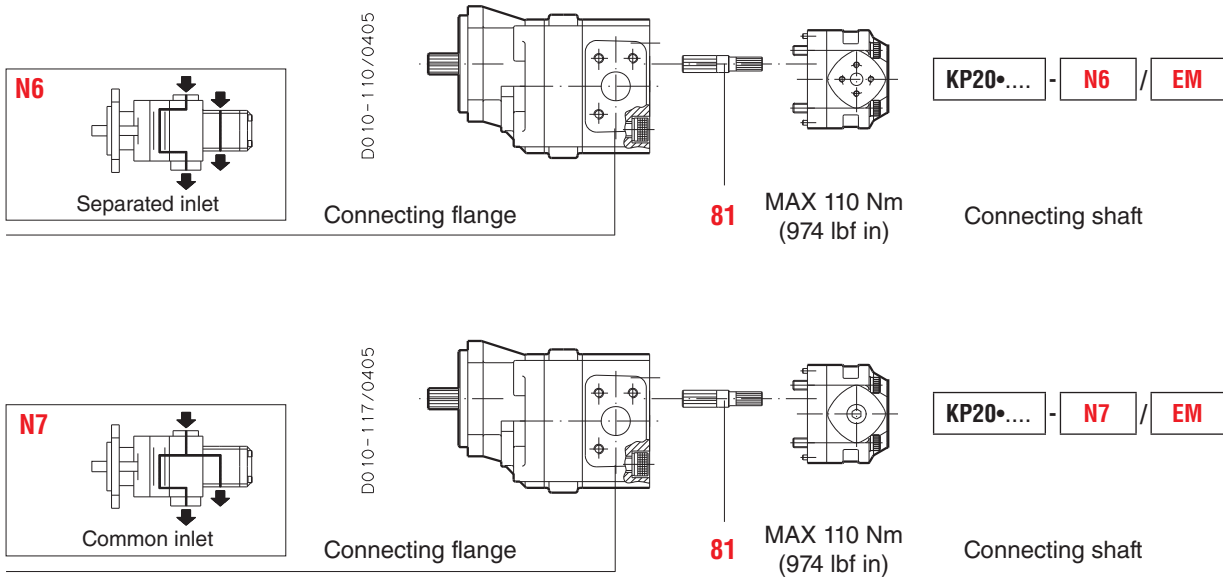

Replaces: 01/07.2005

02/06.2012

## DOUBLE PUMPS HDP35 / PLP20

### STANDARD VERSION

Replaces: 01/07.2005

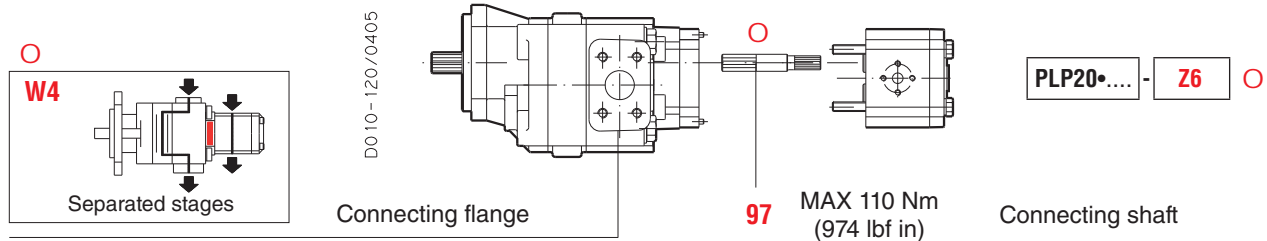
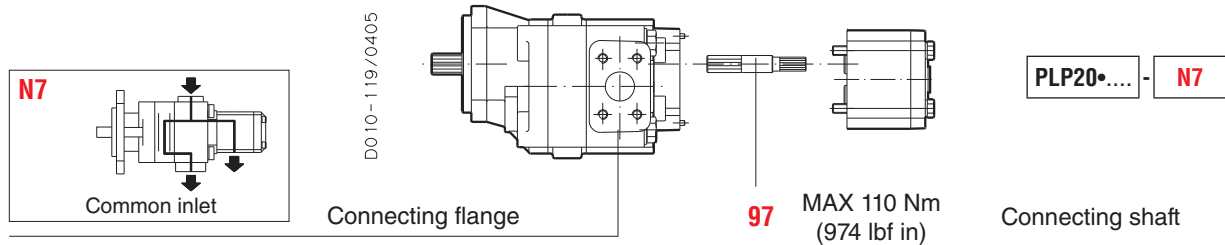
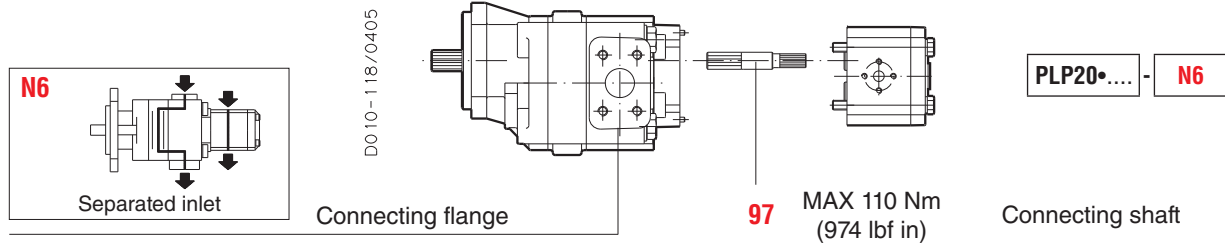

### EM VERSION

02/06.2012

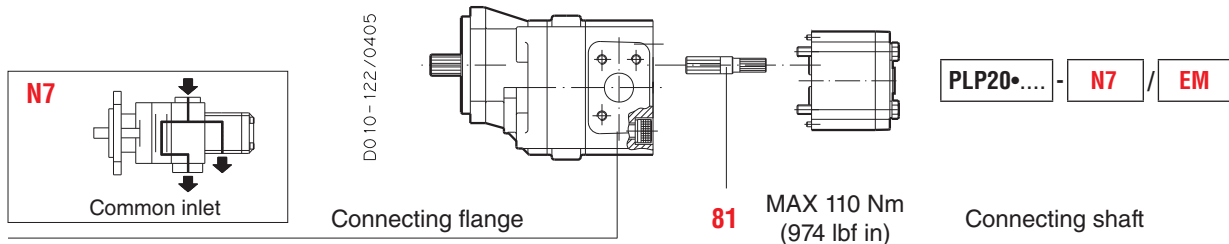
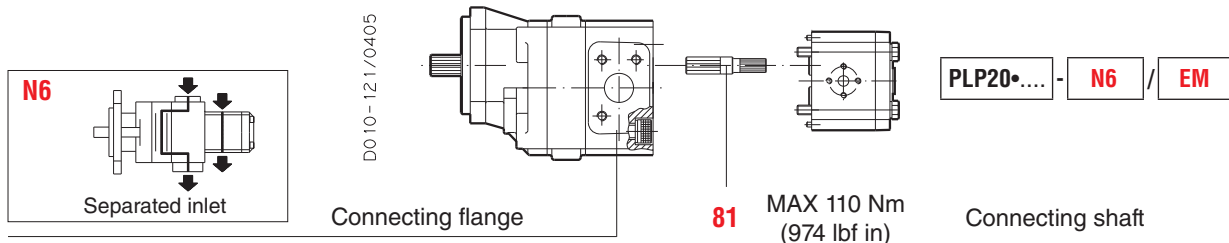

## MULTIPLE PUMPS SAME GROUPS

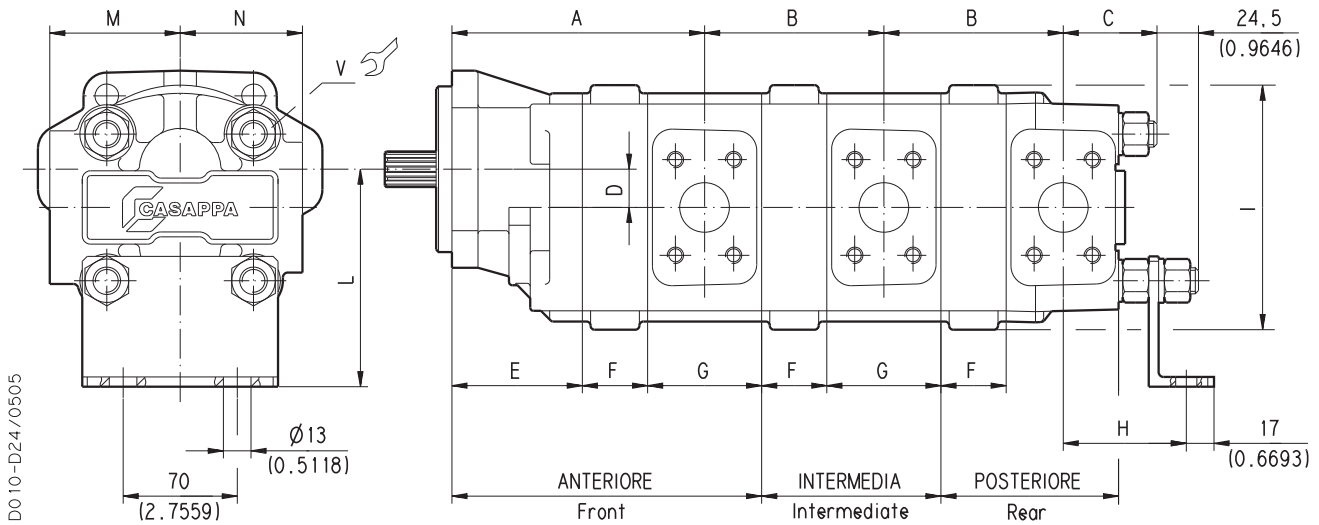

D010-D24/0505

Tightening torque  
Nm (lbf in)

**V**

280 ±28 (2230 ÷ 2726)

DRIVE SHAFTS:  
see page 47

MOUNTING FLANGE:  
see page 48 ÷ 50

PORTS:  
see page 51

The drawing shows a pump with left rotation.

Pump type	A	B	C	D	E	G	H	I	L	M (IN)	N (OUT)
	mm (inch)	mm (inch)	mm (inch)	mm (inch)	mm (inch)	mm (inch)	mm (inch)	mm (inch)	mm (inch)	mm (inch)	mm (inch)
<b>HDP35/35</b>	139+F (5.4724+F)	82+F (3.2283+F)	60,5 (2.3819)	27,35 (1.0807)	98 (3.8583)	82 (3.2283)	91,5 (3.6024)	172 (6.7717)	162,4 (6.3937)	90 (3.5433)	85 (3.3465)
<b>HDP30/30</b>	115+F (4.5276+F)	70+F (2.7559+F)	54,5 (2.1457)	23,45 (0.9232)	80 (3.1496)	70 (2.7559)	75,5 (2.9724)	150 (5.9055)	133,5 (5.2559)	80 (3.1496)	75 (2.9528)

Pump type	F
	mm (inch)
<b>HDP 35•40</b>	33 (1.2992)
<b>HDP 35•50</b>	38 (1.4961)
<b>HDP 35•63</b>	44 (1.7323)
<b>HDP 35•71</b>	48 (1.8898)
<b>HDP 35•80</b>	52 (2.0472)
<b>HDP 35•90</b>	57 (2.2441)
<b>HDP 35•100</b>	61 (2.4016)
<b>HDP 35•112</b>	67 (2.6378)
<b>HDP 35•125</b>	73 (2.8740)

Pump type	F
	mm (inch)
<b>HDP 30•17</b>	23 (0.9055)
<b>HDP 30•22</b>	26 (1.0236)
<b>HDP 30•24</b>	27,3 (1.0748)
<b>HDP 30•27</b>	29 (1.1417)
<b>HDP 30•34</b>	34 (1.3386)
<b>HDP 30•38</b>	37 (1.4567)
<b>HDP 30•43</b>	40 (1.5748)
<b>HD. 30•51</b>	45 (1.7717)
<b>HDP 30•56</b>	48 (1.8898)
<b>HDP 30•61</b>	51 (2.0079)
<b>HDP 30•73</b>	59 (2.3228)
<b>HDP 30•82</b>	64 (2.5197)

01/07.2005

**MULTIPLE PUMPS HDP35 / HDP30**

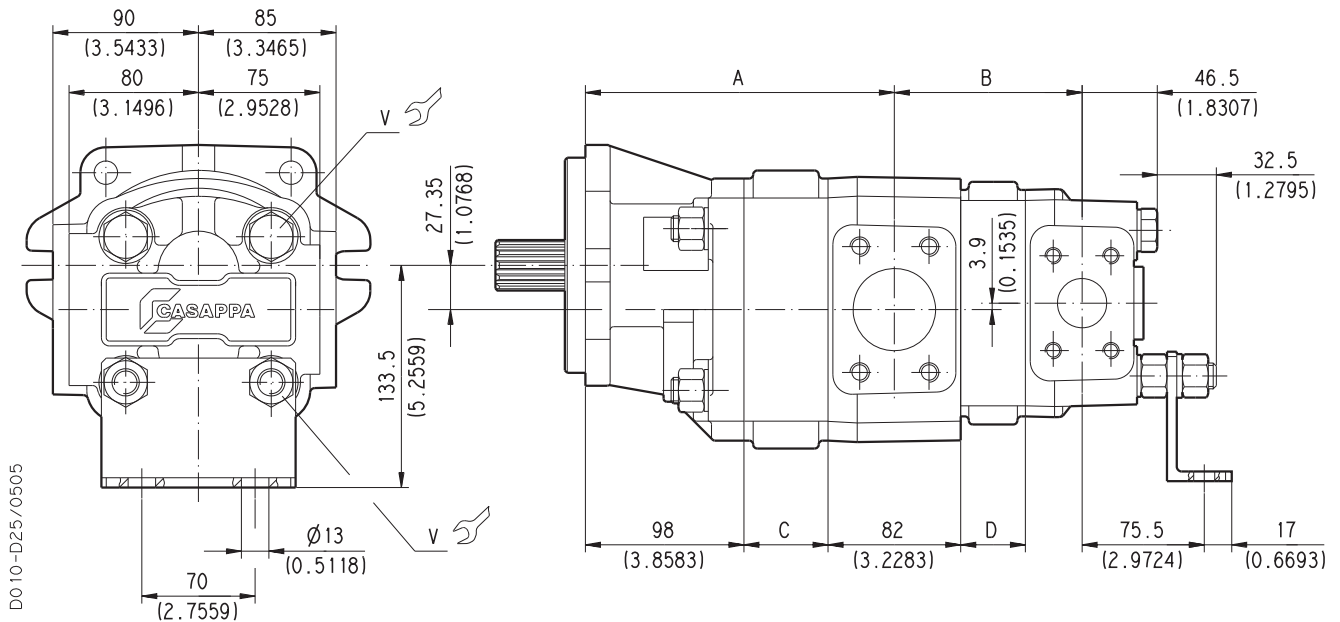

D010-D25/0505

Tightening torque  
Nm (lbf in)

**V**

280 <sup>±28</sup> (2230 ÷ 2726)

DRIVE SHAFTS:  
see page 47

MOUNTING FLANGE:  
see page 49 ÷ 50

PORTS:  
see page 51

The draw shows a pump with left rotation.

Pump type	<b>A</b>		<b>B</b>	
	mm (inch)		mm (inch)	
<b>HDP35/30</b>	139+C (5.4724+C)		76+D (2.9921+D)	

Pump type	<b>C</b>	
	mm (inch)	
<b>HDP 35•40</b>	33 (1.2992)	
<b>HDP 35•50</b>	38 (1.4961)	
<b>HDP 35•63</b>	44 (1.7323)	
<b>HDP 35•71</b>	48 (1.8898)	
<b>HDP 35•80</b>	52 (2.0472)	
<b>HDP 35•90</b>	57 (2.2441)	
<b>HDP 35•100</b>	61 (2.4016)	
<b>HDP 35•112</b>	67 (2.6378)	
<b>HDP 35•125</b>	73 (2.8740)	

Pump type	<b>D</b>	
	mm (inch)	
<b>HDP 30•17</b>	23 (0.9055)	
<b>HDP 30•22</b>	26 (1.0236)	
<b>HDP 30•24</b>	27,3 (1.0748)	
<b>HDP 30•27</b>	29 (1.1417)	
<b>HDP 30•34</b>	34 (1.3386)	
<b>HDP 30•38</b>	37 (1.4567)	
<b>HDP 30•43</b>	40 (1.5748)	
<b>HD. 30•51</b>	45 (1.7717)	
<b>HDP 30•56</b>	48 (1.8898)	
<b>HDP 30•61</b>	51 (2.0079)	
<b>HDP 30•73</b>	59 (2.3228)	
<b>HDP 30•82</b>	64 (2.5197)	

01/07.2005

**DOUBLE PUMPS HDP../ KP20 STANDARD VERSION**

**SEPARATED INLET**

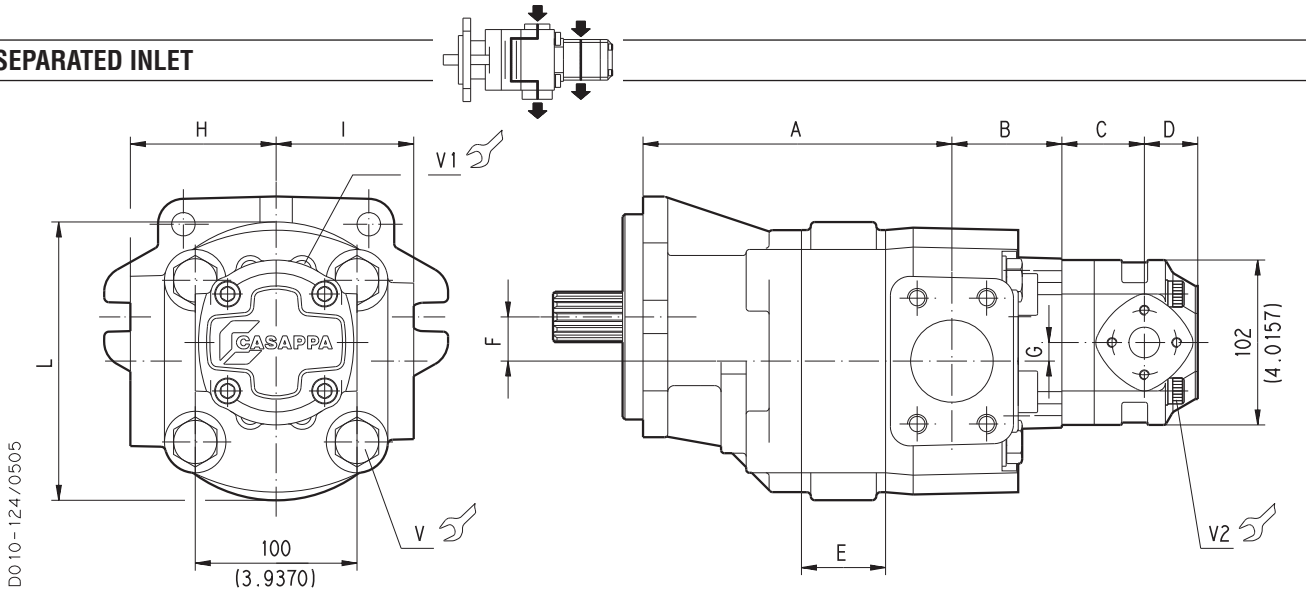

**COMMON INLET**

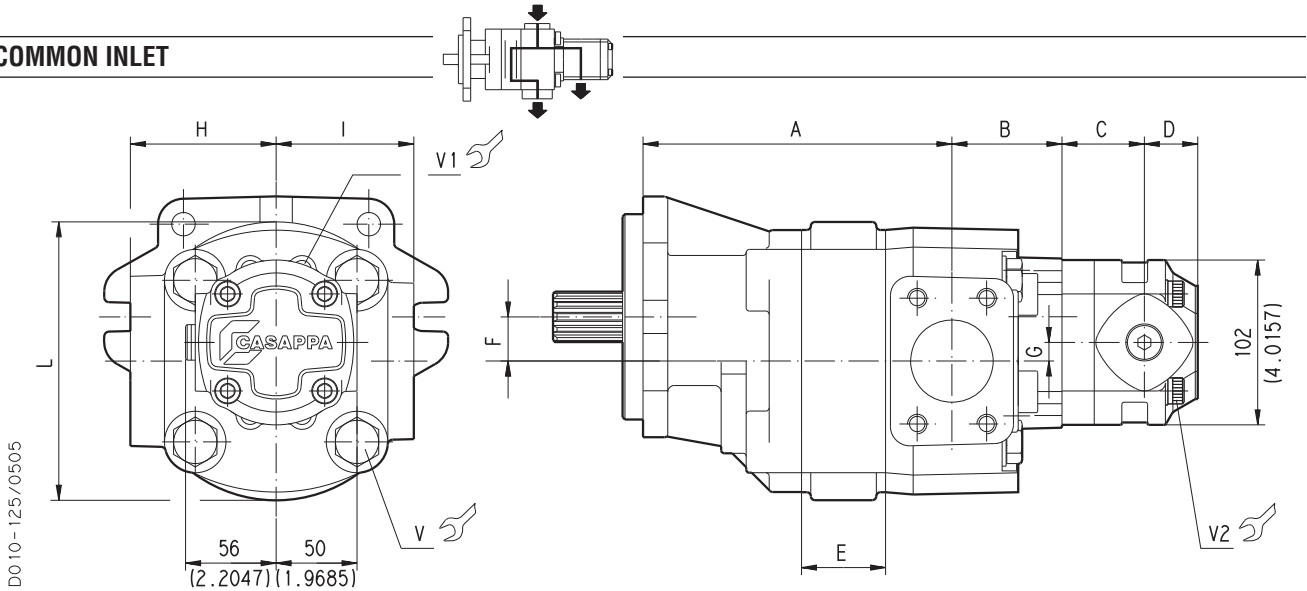

**SEPARATED STAGES**

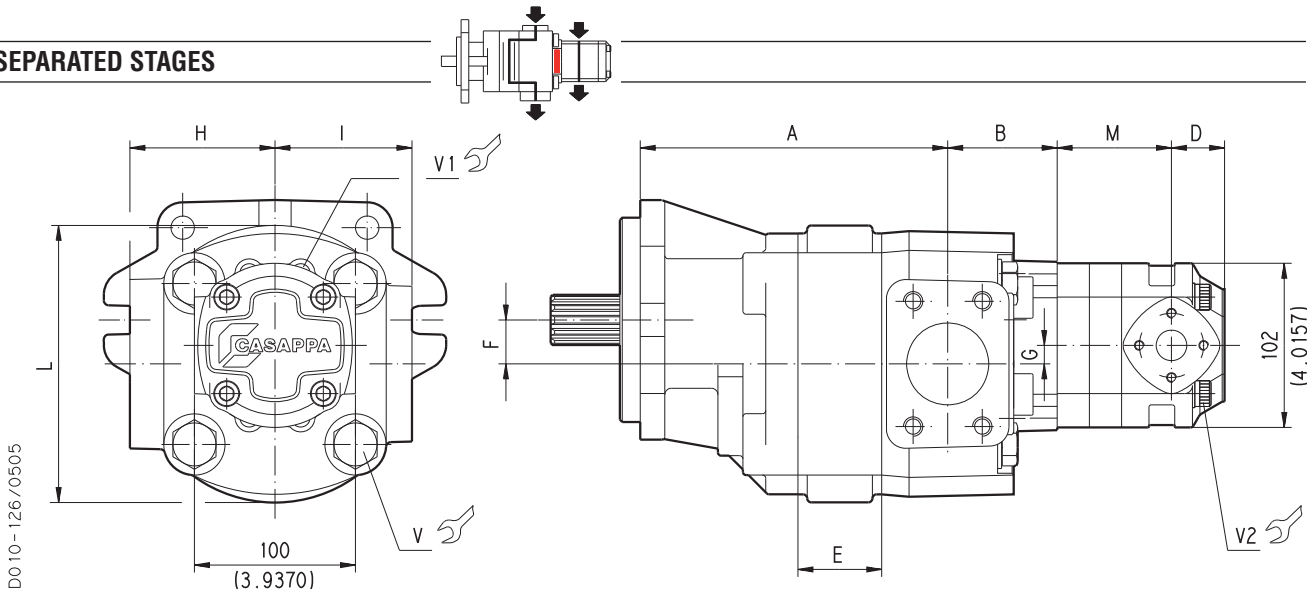

01/07.2005

## DOUBLE PUMPS HDP../ KP20 STANDARD VERSION

Tightening torque Nm (lbf in)

V	V1	V2
280 <sup>±28</sup> (2230 ÷ 2726)	25 <sup>±2,5</sup> (199 ÷ 243)	70 <sup>±7</sup> (558 ÷ 682)

Drawings show pumps with left rotation.

Pump type	A	B	F	G	H (IN)	I (OUT)	L
	mm (inch)	mm (inch)	mm (inch)	mm (inch)	mm (inch)	mm (inch)	mm (inch)
<b>HDP35/KP20</b>	139+E (5.4724+E)	68 (2.6772)	27,35 (1.0807)	11,27 (0.4437)	90 (3.5433)	85 (3.3465)	172 (6.7717)
<b>HDP30/KP20</b>	115+E (4.5276+E)	62 (2.4409)	23,45 (0.9232)	7,45 (0.2933)	80 (3.1496)	75 (2.9528)	150 (5.9055)

Pump type	E
	mm (inch)
<b>HDP 35•40</b>	33 (1.2992)
<b>HDP 35•50</b>	38 (1.4961)
<b>HDP 35•63</b>	44 (1.7323)
<b>HDP 35•71</b>	48 (1.8898)
<b>HDP 35•80</b>	52 (2.0472)
<b>HDP 35•90</b>	57 (2.2441)
<b>HDP 35•100</b>	61 (2.4016)
<b>HDP 35•112</b>	67 (2.6378)
<b>HDP 35•125</b>	73 (2.8740)

Pump type	E
	mm (inch)
<b>HDP 30•17</b>	23 (0.9055)
<b>HDP 30•22</b>	26 (1.0236)
<b>HDP 30•24</b>	27,3 (1.0748)
<b>HDP 30•27</b>	29 (1.1417)
<b>HDP 30•34</b>	34 (1.3386)
<b>HDP 30•38</b>	37 (1.4567)
<b>HDP 30•43</b>	40 (1.5748)
<b>HD. 30•51</b>	45 (1.7717)
<b>HDP 30•56</b>	48 (1.8898)
<b>HDP 30•61</b>	51 (2.0079)
<b>HDP 30•73</b>	59 (2.3228)
<b>HDP 30•82</b>	64 (2.5197)

DRIVE SHAFTS:  
see page 47

MOUNTING FLANGE:  
see page 48 ÷ 50

PORTS:  
see page 51

01/07.2005

Pump type	C	D	M
	mm (inch)	mm (inch)	mm (inch)
<b>KP 20•4</b>	44,5 (1.7520)	27,5 (1.0827)	61,5 (2.4213)
<b>KP 20•6,3</b>	47 (1.8504)	27,5 (1.0827)	64 (2.5197)
<b>KP 20•8</b>	49,5 (1.9488)	27,5 (1.0827)	66,5 (2.6181)
<b>KP 20•11,2</b>	53 (2.0866)	27,5 (1.0827)	70 (2.7559)
<b>KP 20•14</b>	51,5 (2.0276)	33 (1.2992)	68,5 (2.6969)
<b>KP 20•16</b>	57 (2.2441)	33 (1.2992)	74 (2.9134)
<b>KP 20•20</b>	63,5 (2.5000)	33 (1.2992)	80,5 (3.1693)
<b>KP 20•25</b>	56,5 (2.2244)	48 (1.8898)	73,5 (2.8937)
<b>KP 20•31,5</b>	66,5 (2.6181)	48 (1.8898)	83,5 (3.2874)

## DOUBLE PUMPS HDP.. / PLP20 STANDARD VERSION

### SEPARATED INLET

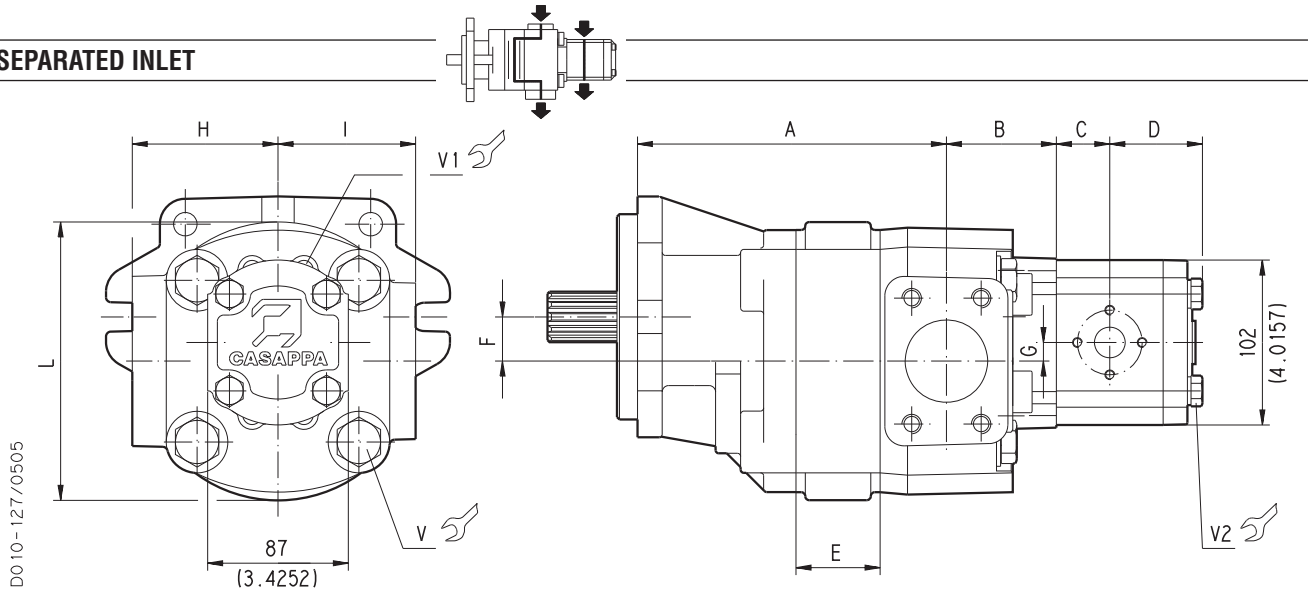

### COMMON INLET

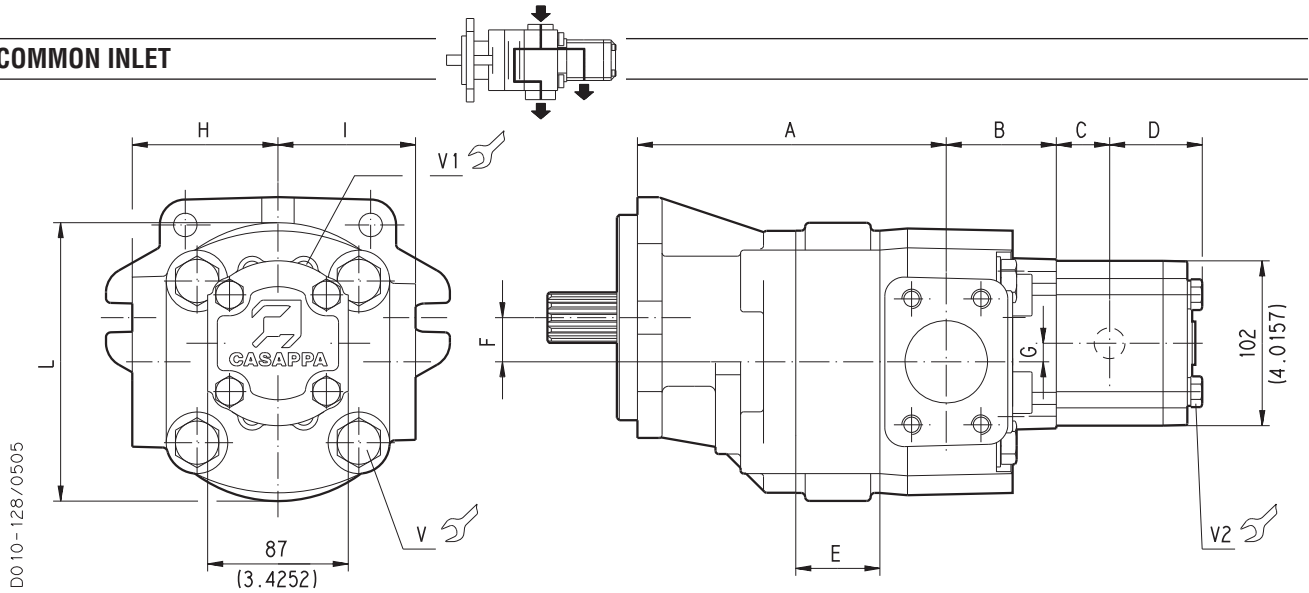

### SEPARATED STAGES

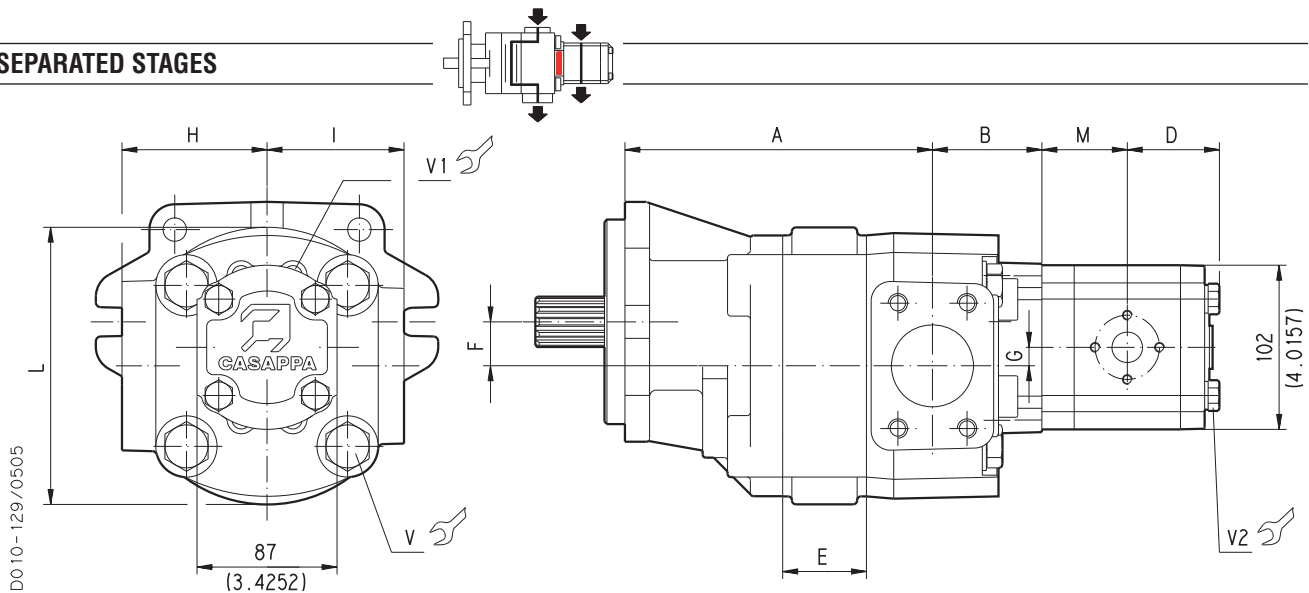

01/07.2005

## DOUBLE PUMPS HDP.. / PLP20 STANDARD VERSION

Tightening torque Nm (lbf in)

V	V1	V2
280 <sup>±28</sup> (2230 ÷ 2726)	25 <sup>±2,5</sup> (199 ÷ 243)	70 <sup>±7</sup> (558 ÷ 682)

Drawings show pumps with left rotation.

	A	B	F	G	H (IN)	I (OUT)	L
Pump type	mm (inch)	mm (inch)	mm (inch)	mm (inch)	mm (inch)	mm (inch)	mm (inch)
<b>HDP35/PLP20</b>	139+E (5.4724+E)	68 (2.6772)	27,35 (1.0807)	11,27 (0.4437)	90 (3.5433)	85 (3.3465)	172 (6.7717)
<b>HDP30/PLP20</b>	115+E (4.5276+E)	62 (2.4409)	23,45 (0.9232)	7,45 (0.2933)	80 (3.1496)	75 (2.9528)	150 (5.9055)

	E		E
Pump type	mm (inch)	Pump type	mm (inch)
<b>HDP 35•40</b>	33 (1.2992)	<b>HDP 30•17</b>	23 (0.9055)
<b>HDP 35•50</b>	38 (1.4961)	<b>HDP 30•22</b>	26 (1.0236)
<b>HDP 35•63</b>	44 (1.7323)	<b>HDP 30•24</b>	27,3 (1.0748)
<b>HDP 35•71</b>	48 (1.8898)	<b>HDP 30•27</b>	29 (1.1417)
<b>HDP 35•80</b>	52 (2.0472)	<b>HDP 30•34</b>	34 (1.3386)
<b>HDP 35•90</b>	57 (2.2441)	<b>HDP 30•38</b>	37 (1.4567)
<b>HDP 35•100</b>	61 (2.4016)	<b>HDP 30•43</b>	40 (1.5748)
<b>HDP 35•112</b>	67 (2.6378)	<b>HD. 30•51</b>	45 (1.7717)
<b>HDP 35•125</b>	73 (2.8740)	<b>HDP 30•56</b>	48 (1.8898)
		<b>HDP 30•61</b>	51 (2.0079)
		<b>HDP 30•73</b>	59 (2.3228)
		<b>HDP 30•82</b>	64 (2.5197)

DRIVE SHAFTS:  
see page 47

MOUNTING FLANGE:  
see page 48 ÷ 50

PORTS:  
see page 51

	C	D	M
Pump type	mm (inch)	mm (inch)	mm (inch)
<b>PLP 20•4</b>	25,75 (1.0138)	49,25 (1.9390)	42,75 (1.6831)
<b>PLP 20•6,3</b>	27 (1.0630)	50,5 (1.9882)	44 (1.7323)
<b>PLP 20•7,2</b>	27,5 (1.0826)	51 (2.0079)	44,5 (1.7520)
<b>PLP 20•8</b>	28,25 (1.1122)	51,75 (2.0374)	45,25 (1.7815)
<b>PLP 20•9</b>	28,9 (1.1378)	52,4 (2.0630)	45,9 (1.8071)
<b>PLP 20•10,5</b>	30,25 (1.1909)	53,75 (2.1161)	47,25 (1.8602)
<b>PLP 20•11,2</b>	30,5 (1.2008)	54 (2.1260)	47,5 (1.8701)
<b>PLP 20•14</b>	33 (1.2992)	56,5 (2.2244)	50 (1.9685)
<b>PLP 20•16</b>	34,75 (1.3681)	58,25 (2.2933)	51,75 (2.0374)
<b>PLP 20•19</b>	36,45 (1.4350)	59,95 (2.3602)	53,45 (2.1043)
<b>PLP 20•20</b>	38 (1.4961)	61,5 (2.4213)	55 (2.1654)
<b>PLP 20•24,5</b>	40,8 (1.6063)	64,3 (2.5315)	57,8 (2.2756)
<b>PLP 20•25</b>	42 (1.6535)	65,5 (2.5787)	59 (2.3228)
<b>PLP 20•27,5</b>	43,35 (1.7067)	66,85 (2.6319)	60,35 (2.3760)
<b>PLP 20•31,5</b>	47 (1.8504)	70,5 (2.7756)	64 (2.5197)

01/07.2005

## DOUBLE PUMPS HDP35 / KP20 EM VERSION

### SEPARATED INLET

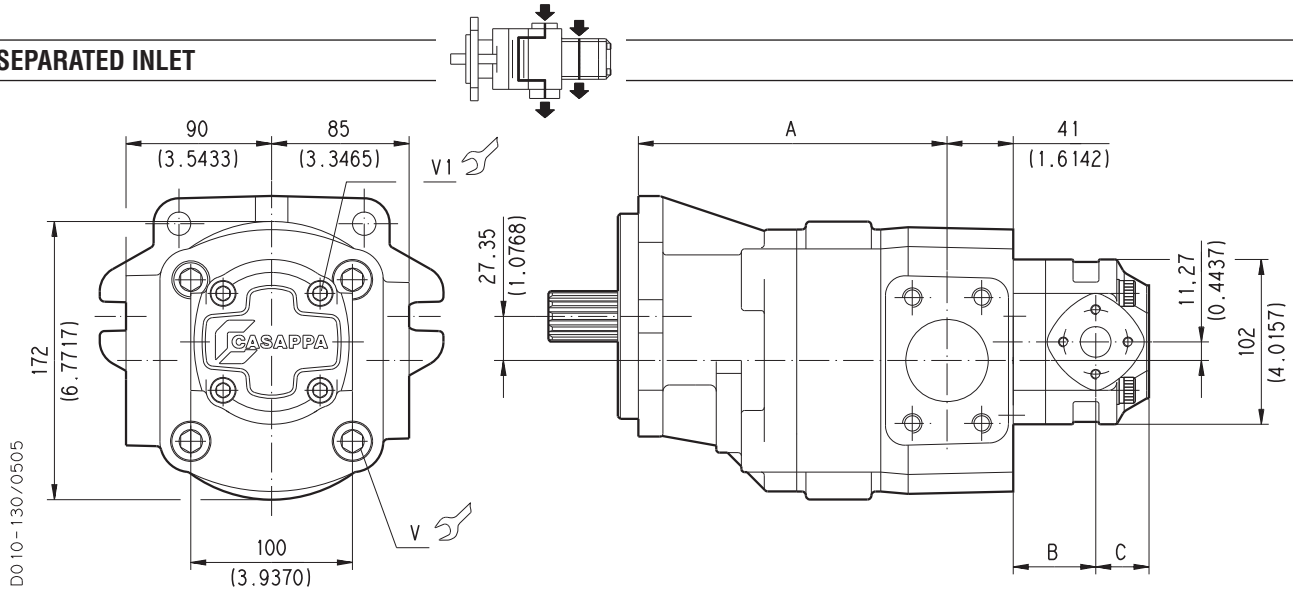

### COMMON INLET

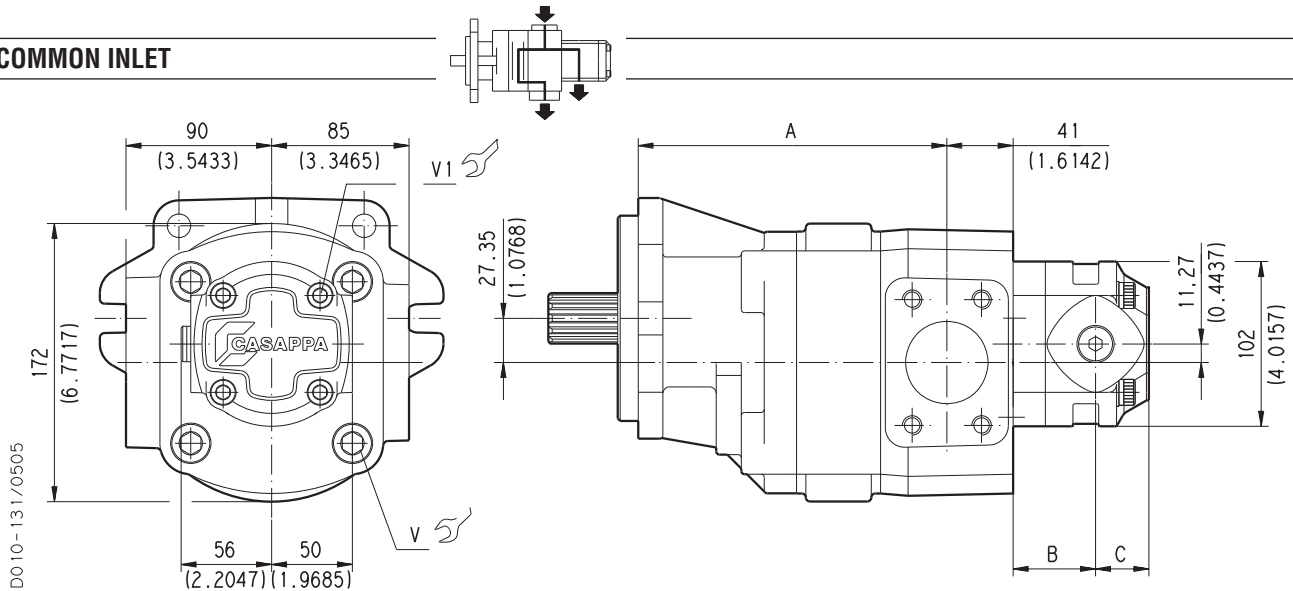

Tightening torque Nm (lbf in)

**V**

**V1**

280 ±28 (2230 ÷ 2726)    70 ±7 (558 ÷ 682)

Drawings show pumps with left rotation.

DRIVE SHAFTS:  
see page 47

MOUNTING FLANGE:  
see page 49 ÷ 50

PORTS:  
see page 51

Pump type	<b>A</b>
	mm (inch)
<b>HDP 35•40</b>	172 (6.7717)
<b>HDP 35•50</b>	177 (6.9685)
<b>HDP 35•63</b>	183 (7.2047)
<b>HDP 35•71</b>	187 (7.3622)
<b>HDP 35•80</b>	191 (7.5197)
<b>HDP 35•90</b>	196 (7.7165)
<b>HDP 35•100</b>	200 (7.8740)
<b>HDP 35•112</b>	206 (8.1102)
<b>HDP 35•125</b>	212 (8.3465)

Pump type	<b>B</b>	<b>C</b>
	mm (inch)	mm (inch)
<b>KP 20•4</b>	44,5 (1.7520)	27,5 (1.0827)
<b>KP 20•6,3</b>	47 (1.8504)	27,5 (1.0827)
<b>KP 20•8</b>	49,5 (1.9488)	27,5 (1.0827)
<b>KP 20•11,2</b>	53 (2.0866)	27,5 (1.0827)
<b>KP 20•14</b>	51,5 (2.0276)	33 (1.2992)
<b>KP 20•16</b>	57 (2.2441)	33 (1.2992)
<b>KP 20•20</b>	63,5 (2.5000)	33 (1.2992)
<b>KP 20•25</b>	56,5 (2.2244)	48 (1.8898)
<b>KP 20•31,5</b>	66,5 (2.6181)	48 (1.8898)

01/07.2005

## DOUBLE PUMPS HDP35 / PL20 EM VERSION

### SEPARATED INLET

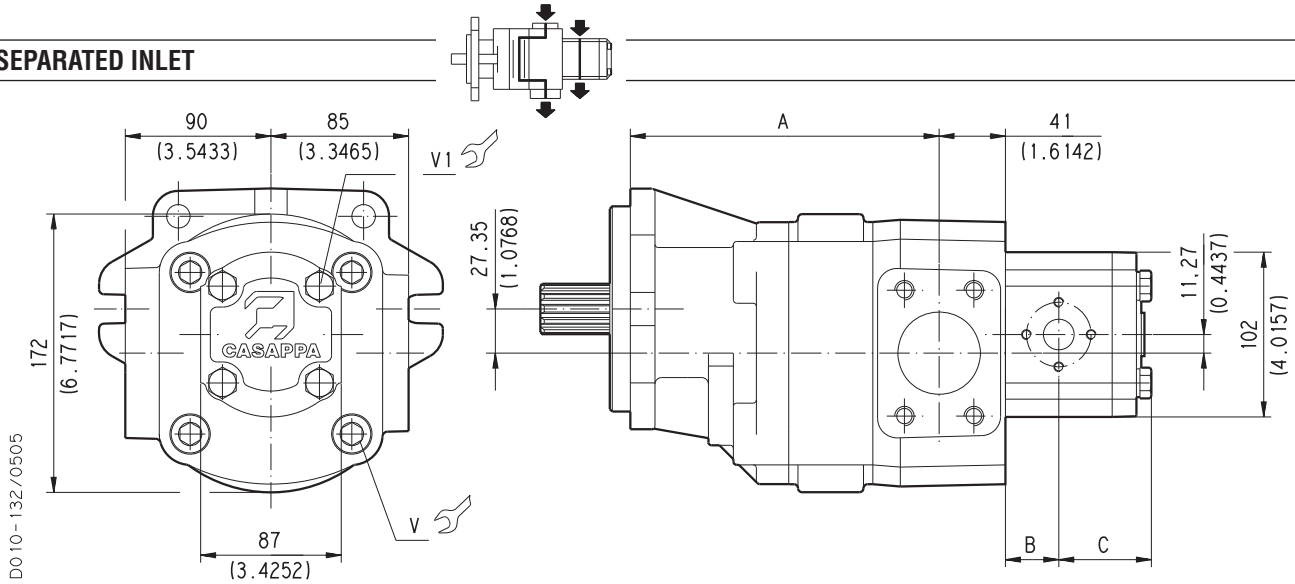

### COMMON INLET

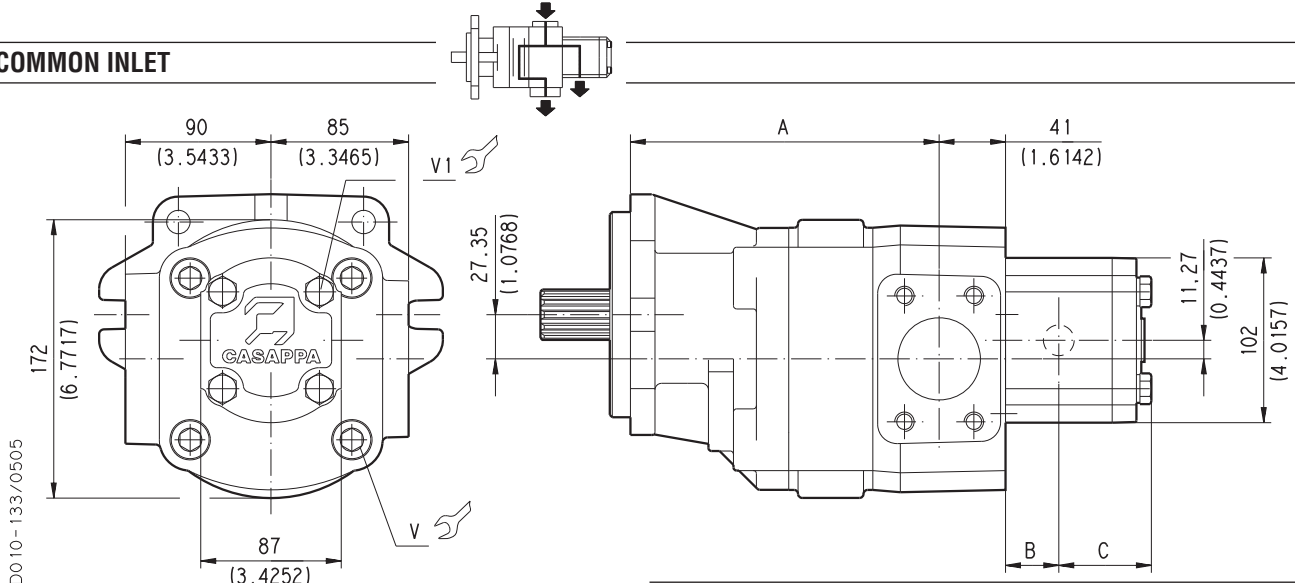

Drawings show pumps with left rotation.

Tightening torque Nm (lbf in)

**V**

**V1**

280 ±28 (2230 ÷ 2726) 70 ±7 (558 ÷ 682)

01/07.2005

DRIVE  
SHAFTS:  
see page 47

MOUNTING  
FLANGE:  
see page 49 ÷ 50

PORTS:  
see page 51

Pump type	A
	mm (inch)
<b>HDP 35•40</b>	172 (6.7717)
<b>HDP 35•50</b>	177 (6.9685)
<b>HDP 35•63</b>	183 (7.2047)
<b>HDP 35•71</b>	187 (7.3622)
<b>HDP 35•80</b>	191 (7.5197)
<b>HDP 35•90</b>	196 (7.7165)
<b>HDP 35•100</b>	200 (7.8740)
<b>HDP 35•112</b>	206 (8.1102)
<b>HDP 35•125</b>	212 (8.3465)

Pump type	B	C
	mm (inch)	mm (inch)
<b>PLP 20•4</b>	25,75 (1.0138)	49,25 (1.9390)
<b>PLP 20•6,3</b>	27 (1.0630)	50,5 (1.9882)
<b>PLP 20•7,2</b>	27,5 (1.0826)	51 (2.0079)
<b>PLP 20•8</b>	28,25 (1.1122)	51,75 (2.0374)
<b>PLP 20•9</b>	28,9 (1.1378)	52,4 (2.0630)
<b>PLP 20•10,5</b>	30,25 (1.1909)	53,75 (2.1161)
<b>PLP 20•11,2</b>	30,5 (1.2008)	54 (2.1260)
<b>PLP 20•14</b>	33 (1.2992)	56,5 (2.2244)
<b>PLP 20•16</b>	34,75 (1.3681)	58,25 (2.2933)
<b>PLP 20•19</b>	36,45 (1.4350)	59,95 (2.3602)
<b>PLP 20•20</b>	38 (1.4961)	61,5 (2.4213)
<b>PLP 20•24,5</b>	40,8 (1.6063)	64,3 (2.5315)
<b>PLP 20•25</b>	42 (1.6535)	65,5 (2.5787)
<b>PLP 20•27,5</b>	43,35 (1.7067)	66,85 (2.6319)
<b>PLP 20•31,5</b>	47 (1.8504)	70,5 (2.7756)

## DOUBLE PUMPS HDP30 / KP20 EM VERSION

### SEPARATED INLET

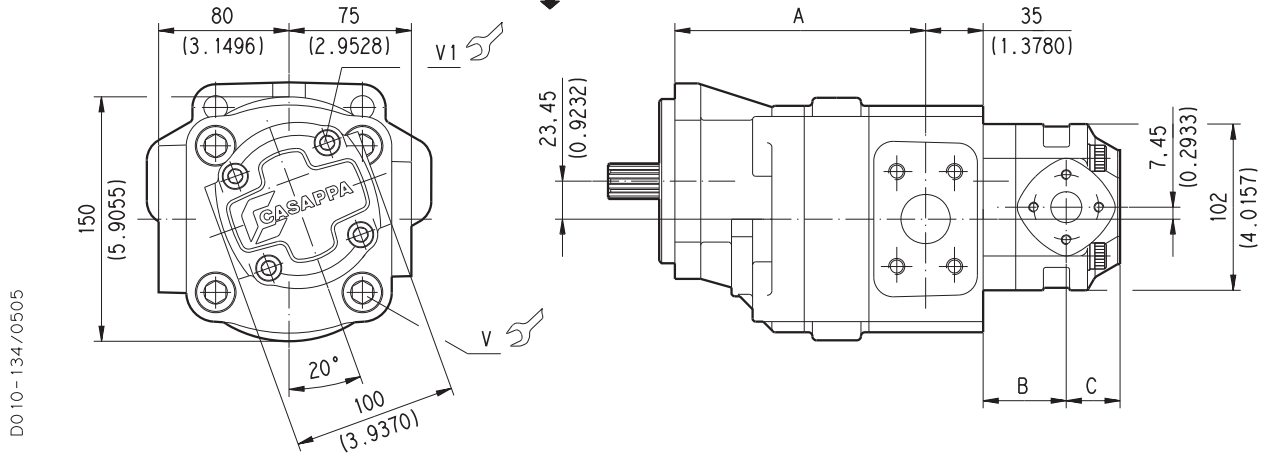

D010-134/0505

### COMMON INLET

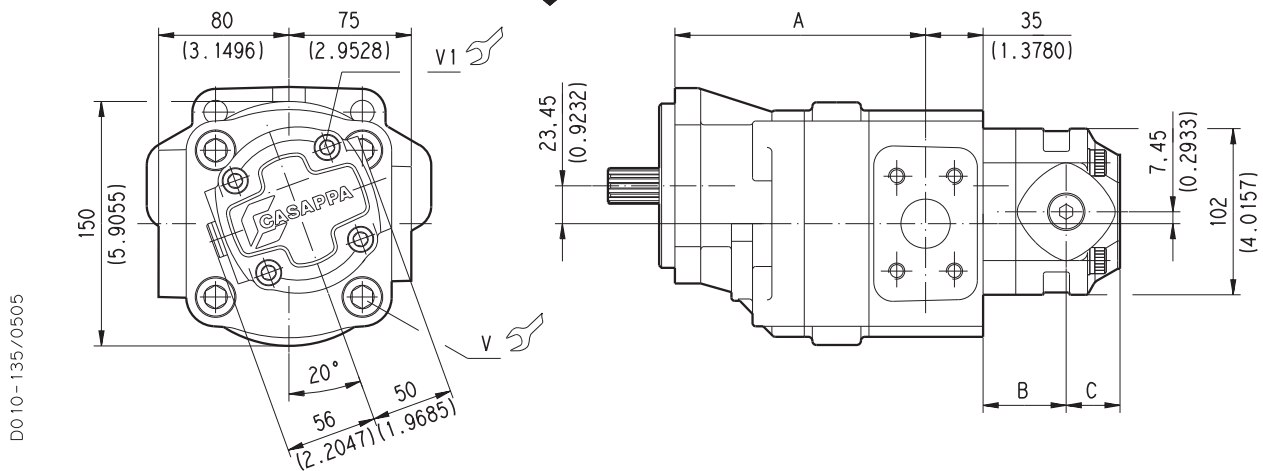

D010-135/0505

Drawings show pumps with left rotation.

Tightening torque Nm (lbf in)

Pump type	A
	mm (inch)
<b>HDP 30•17</b>	138 (5.4331)
<b>HDP 30•22</b>	141 (5.5512)
<b>HDP 30•24</b>	142,3 (5.6024)
<b>HDP 30•27</b>	144 (5.6693)
<b>HDP 30•34</b>	149 (5.8661)
<b>HDP 30•38</b>	152 (5.9843)
<b>HDP 30•43</b>	155 (6.1024)
<b>HD. 30•51</b>	160 (6.2992)
<b>HDP 30•56</b>	163 (6.4173)
<b>HDP 30•61</b>	166 (6.5354)
<b>HDP 30•73</b>	174 (6.8504)
<b>HDP 30•82</b>	179 (7.0472)

DRIVE  
SHAFTS:  
see page 47

MOUNTING  
FLANGE:  
see page 48 ÷ 49

PORTS:  
see page 51

Pump type	V	V1
	mm (inch)	mm (inch)
	280 ±28 (2230 ÷ 2726)	70 ±7 (558 ÷ 682)

  

Pump type	B	C
	mm (inch)	mm (inch)
<b>KP 20•4</b>	44,5 (1.7520)	27,5 (1.0827)
<b>KP 20•6,3</b>	47 (1.8504)	27,5 (1.0827)
<b>KP 20•8</b>	49,5 (1.9488)	27,5 (1.0827)
<b>KP 20•11,2</b>	53 (2.0866)	27,5 (1.0827)
<b>KP 20•14</b>	51,5 (2.0276)	33 (1.2992)
<b>KP 20•16</b>	57 (2.2441)	33 (1.2992)
<b>KP 20•20</b>	63,5 (2.5000)	33 (1.2992)
<b>KP 20•25</b>	56,5 (2.2244)	48 (1.8898)
<b>KP 20•31,5</b>	66,5 (2.6181)	48 (1.8898)

01/07.2005

## DOUBLE PUMPS HDP30 / PLP20 EM VERSION

### SEPARATED INLET

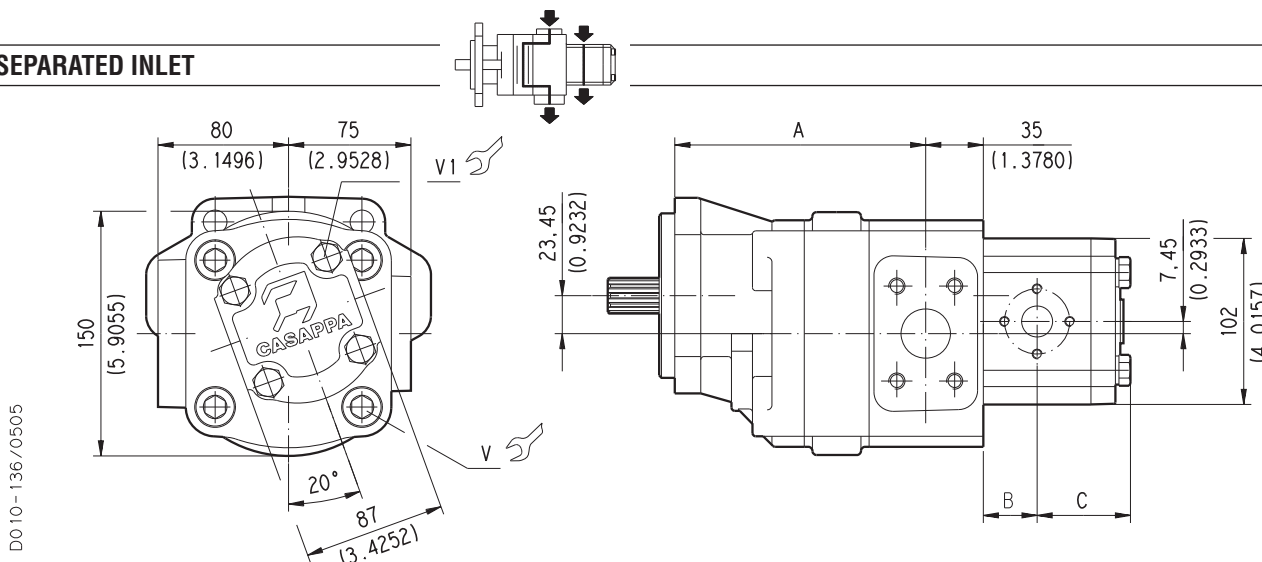

DO 10 - 136 / 0505

### COMMON INLET

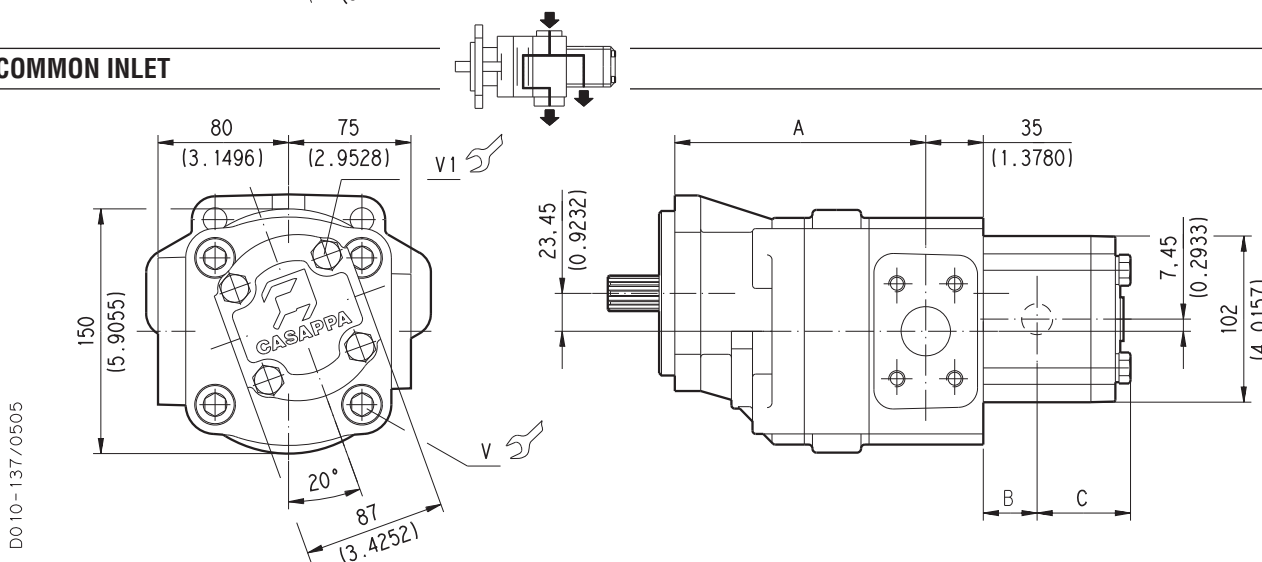

DO 10 - 137 / 0505

Tightening torque Nm (lbf in)

V	V1
280 ±28 (2230 ÷ 2726)	70 ±7 (558 ÷ 682)

Drawings show pumps with left rotation.

Pump type	B	C
	mm (inch)	mm (inch)
<b>PLP 20•4</b>	25,75 (1.0138)	49,25 (1.9390)
<b>PLP 20•6,3</b>	27 (1.0630)	50,5 (1.9882)
<b>PLP 20•7,2</b>	27,5 (1.0826)	51 (2.0079)
<b>PLP 20•8</b>	28,25 (1.1122)	51,75 (2.0374)
<b>PLP 20•9</b>	28,9 (1.1378)	52,4 (2.0630)
<b>PLP 20•10,5</b>	30,25 (1.1909)	53,75 (2.1161)
<b>PLP 20•11,2</b>	30,5 (1.2008)	54 (2.1260)
<b>PLP 20•14</b>	33 (1.2992)	56,5 (2.2244)
<b>PLP 20•16</b>	34,75 (1.3681)	58,25 (2.2933)
<b>PLP 20•19</b>	36,45 (1.4350)	59,95 (2.3602)
<b>PLP 20•20</b>	38 (1.4961)	61,5 (2.4213)
<b>PLP 20•24,5</b>	40,8 (1.6063)	64,3 (2.5315)
<b>PLP 20•25</b>	42 (1.6535)	65,5 (2.5787)
<b>PLP 20•27,5</b>	43,35 (1.7067)	66,85 (2.6319)
<b>PLP 20•31,5</b>	47 (1.8504)	70,5 (2.7756)

Pump type	A
	mm (inch)
<b>HDP 30•17</b>	138 (5.4331)
<b>HDP 30•22</b>	141 (5.5512)
<b>HDP 30•24</b>	142,3 (5.6024)
<b>HDP 30•27</b>	144 (5.6693)
<b>HDP 30•34</b>	149 (5.8661)
<b>HDP 30•38</b>	152 (5.9843)
<b>HDP 30•43</b>	155 (6.1024)
<b>HD. 30•51</b>	160 (6.2992)
<b>HDP 30•56</b>	163 (6.4173)
<b>HDP 30•61</b>	166 (6.5354)
<b>HDP 30•73</b>	174 (6.8504)
<b>HDP 30•82</b>	179 (7.0472)

01/07.2005

DRIVE  
SHAFTS:  
see page 47

MOUNTING  
FLANGE:  
see page 48 ÷ 49

PORTS:  
see page 51

## VERSIONS

For each version, the possible combination between drive shafts and mounting flanges are shown on pages 48 ÷ 50.

**0**

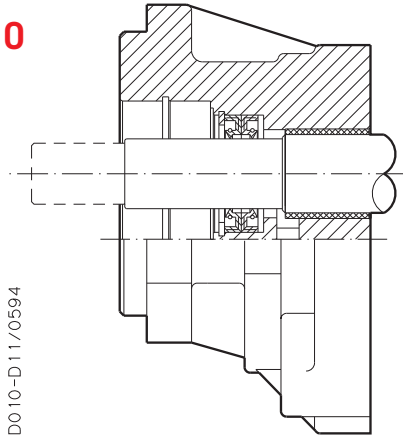

D0 10-D 11/0594

Version for applications without radial and axial load on the drive shaft.

**1**

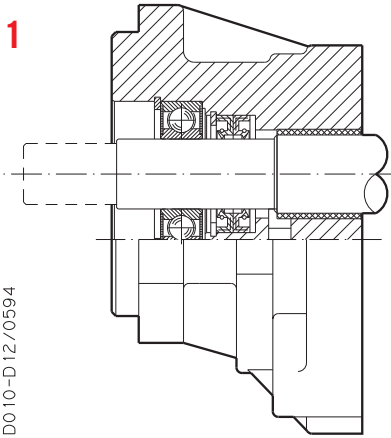

D0 10-D 12/0594

Version for applications with low radial load and without axial load on the drive shaft.

**2**

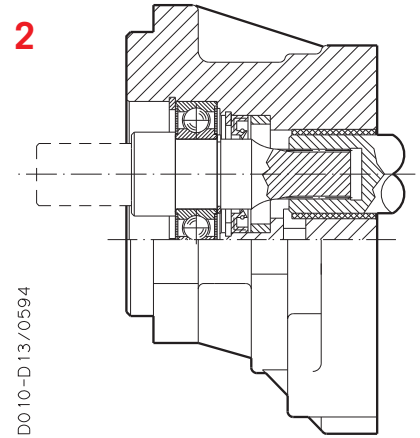

D0 10-D 13/0594

Special version with independent shaft for applications with low radial load and without axial load on the drive shaft.

Max. torque version 2:  
HD. 30: 170 Nm (1505 lbf in)  
HD. 35: 350 Nm (3098 lbf in)

**3**

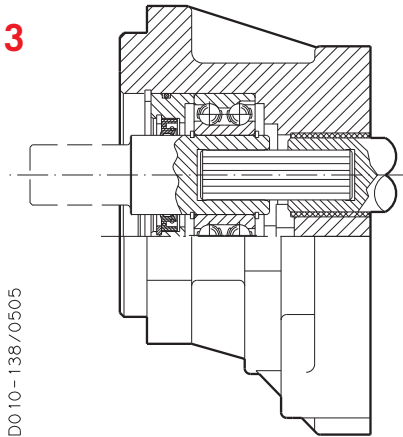

D0 10-138/0505

Version for applications with radial and axial load on the drive shaft.

Max. torque version 3:  
HD. 30: 170 Nm (1505 lbf in)  
HD. 35: 350 Nm (3098 lbf in)

**HD.30**

**4**

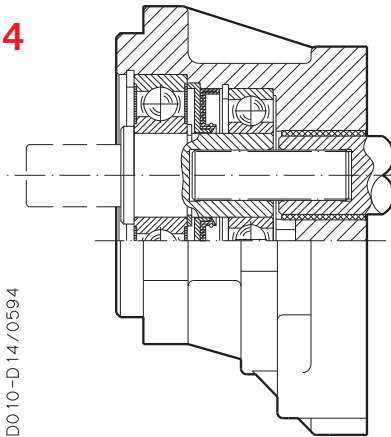

D0 10-D 14/0594

Version for applications with radial and axial load on the drive shaft.

Max. torque version 4:  
HD. 30: 170 Nm (1505 lbf in)

**HD.35**

**4**

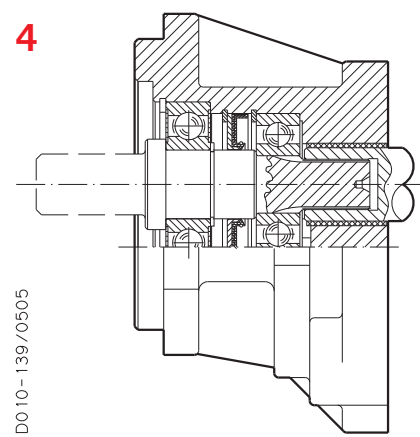

D0 10-139/0505

Version for applications with radial and axial load on the drive shaft.

Max. torque version 4:  
HD. 35: 350 Nm (3098 lbf in)

01/07.2005

For the outboard bearings life expectancy, diagrams providing approximate selection data will be found on subsequent pages. For particular applications please consult our technical sales department.

**VERSION WITH OUTBOARD BEARING MAGNUM 30**

**3**

D010-143/0405

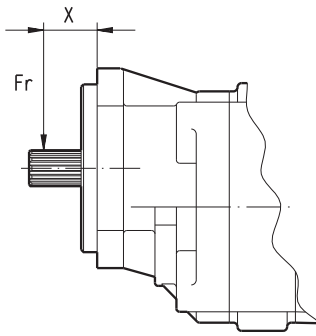

**X** = Distance of the radial load result from the mounting flange [mm(in)].

Each curve has been obtained at:

Lubricant oil ISO VG 46

Temperature 140 °F (60 °C)

Without or with very low axial load

**Example**

Fr Radial load	1000 N (225.0 lbf)
X	30 mm (1.1811 in)
Speed	2000 min <sup>-1</sup>
Rating fatigue life	≈ 1915 h

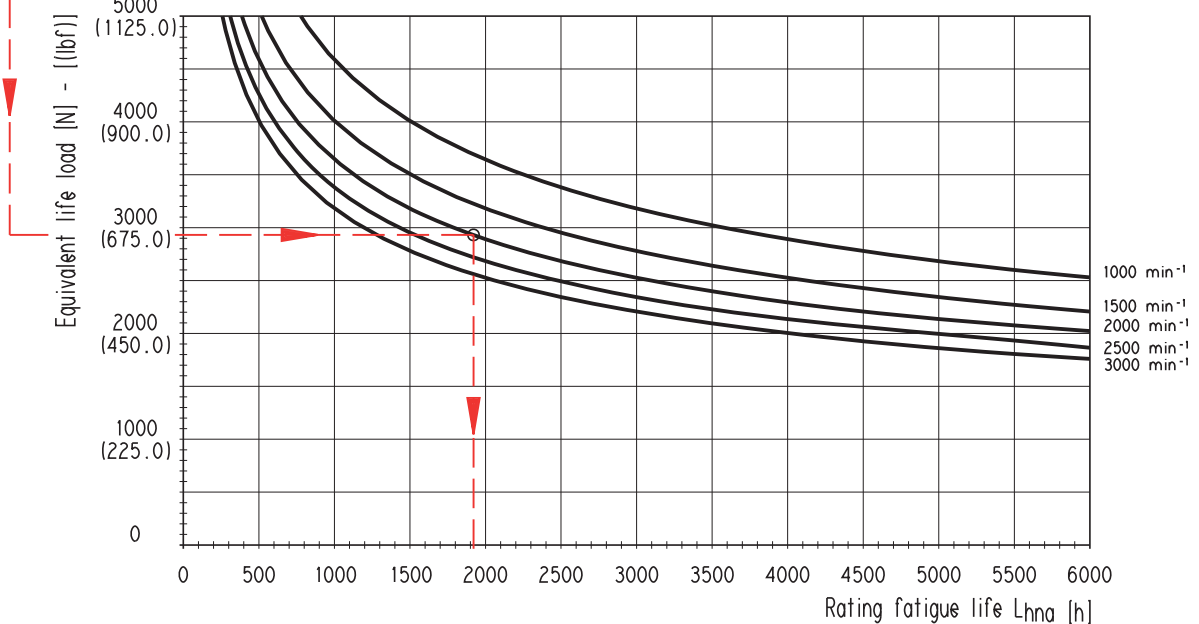
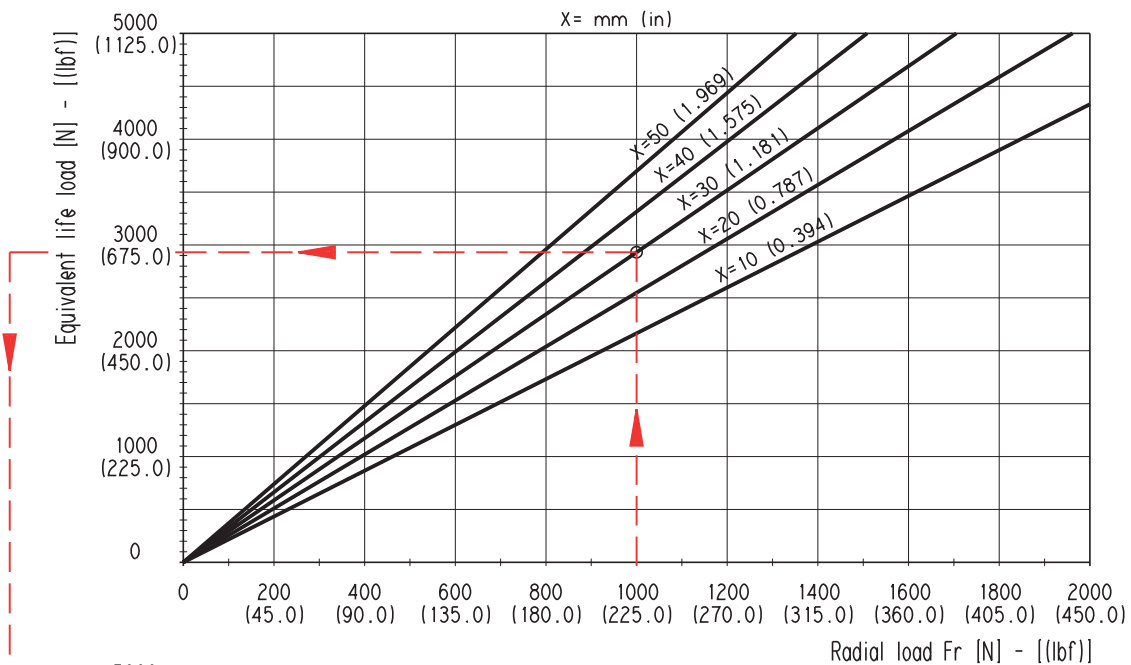

01/07.2005

D010-147/0605

**VERSION WITH OUTBOARD BEARINGS MAGNUM 35**

D010-143/0405

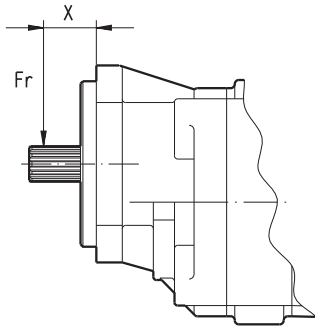

**X** = Distance of the radial load result from the mounting flange [mm(in)].

Each curve has been obtained at:  
Lubricant oil ISO VG 46  
Temperature 140 °F (60 °C)  
Without or with very low axial load

**Example**

Fr Radial load	1000 N (225.0 lbf)
X	30 mm (1.1811 in)
Speed	2000 min <sup>-1</sup>
Rating fatigue life	≈ 5400 h

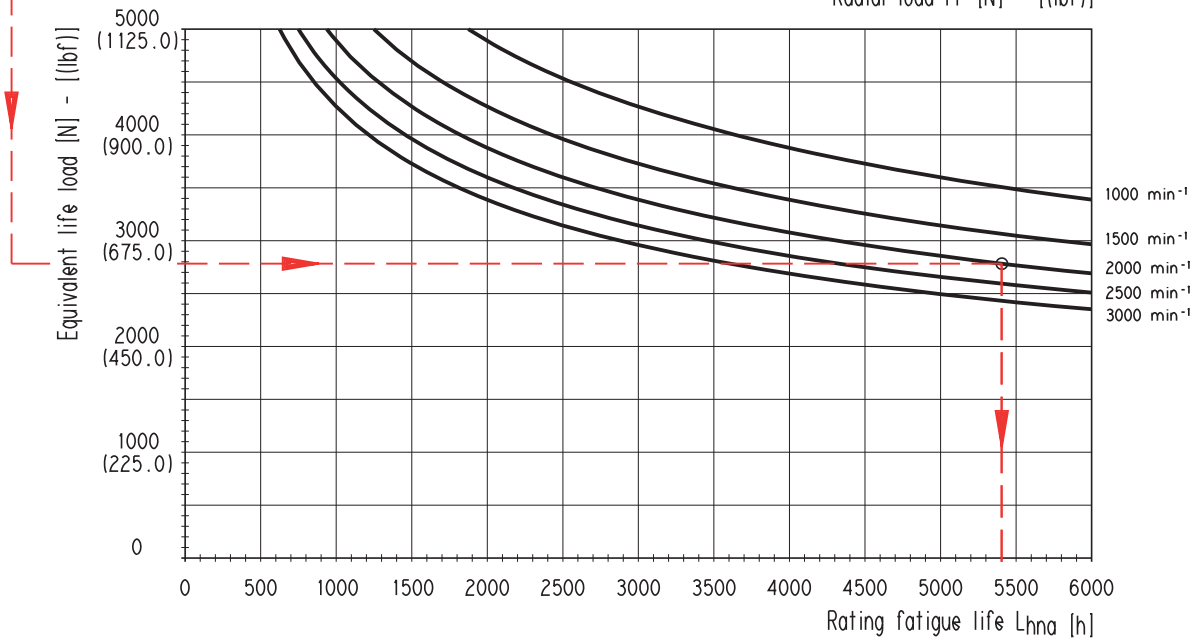
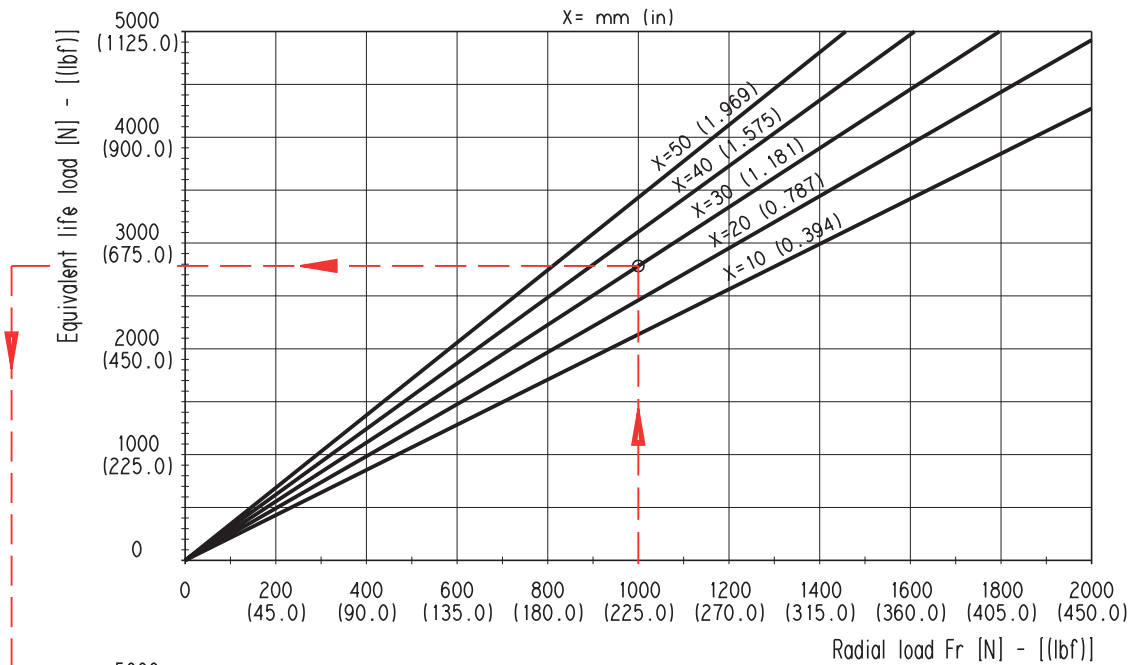

D033-148/0605

01/07.2005

**VERSION WITH OUTBOARD BEARINGS MAGNUM 30**

D010-143/0405

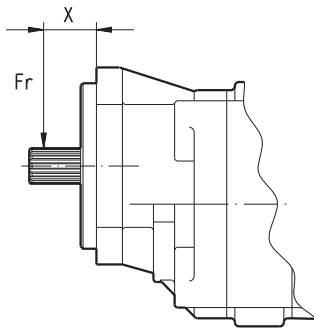

**X** = Distance of the radial load result from the mounting flange [mm(in)].

Each curve has been obtained at:  
Lubricant oil ISO VG 46  
Temperature 140 °F (60 °C)  
Without or with very low axial load

**Example**

Fr Radial load	1500 N (337.5 lbf)
X	30 mm (1.1811 in)
Speed	2000 min <sup>-1</sup>
Rating fatigue life	≈ 2613 h

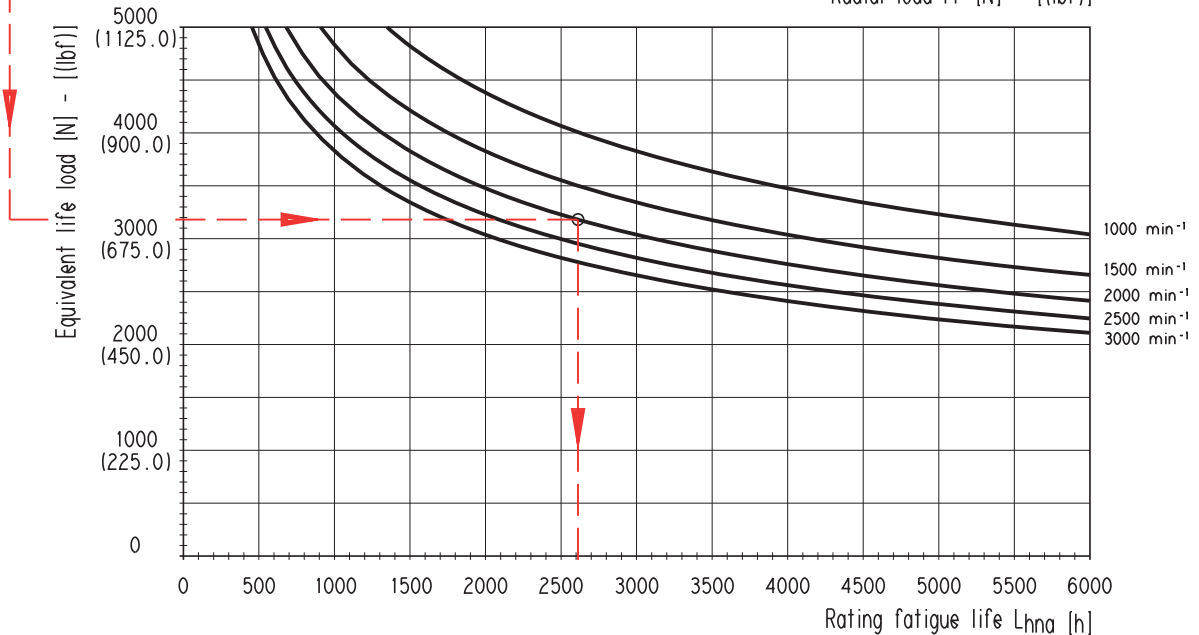
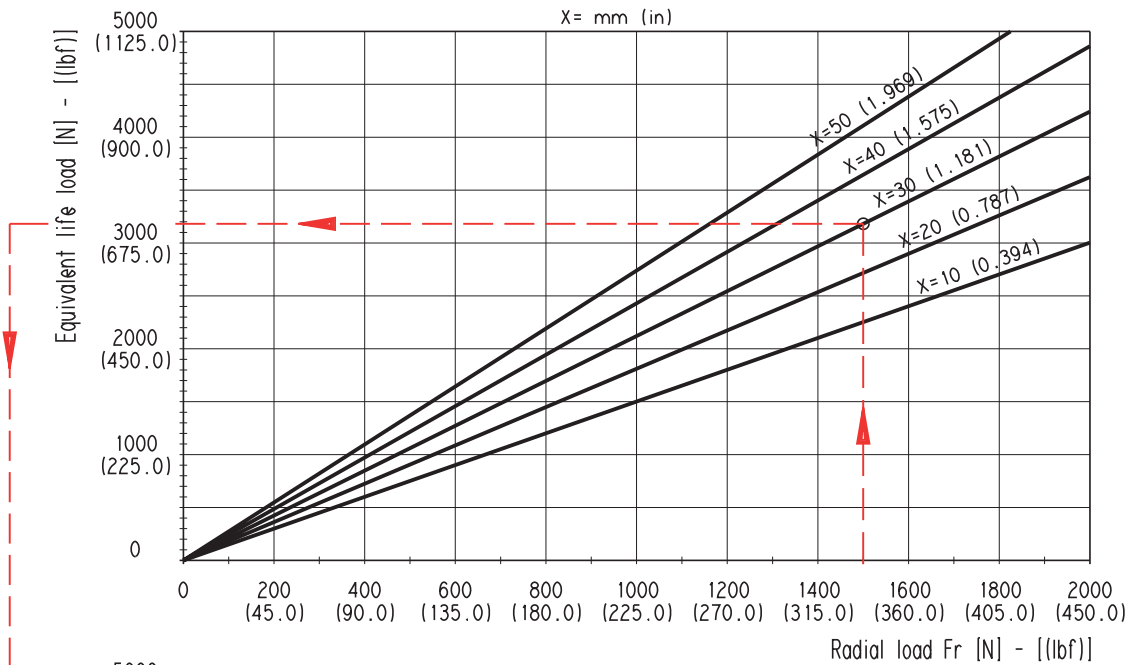

01/07.2005

D010-149/0605

**VERSION WITH OUTBOARD BEARINGS MAGNUM 35**

D010-143/0405

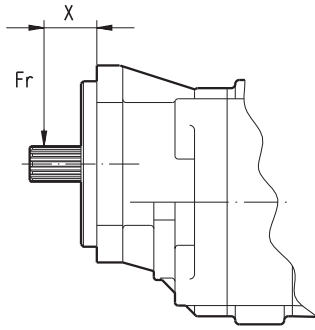

**X** = Distance of the radial load result from the mounting flange [mm(in)].

Each curve has been obtained at:

Lubricant oil ISO VG 46

Temperature 140 °F (60 °C)

Without or with very low axial load

**Example**

Fr Radial load	1500 N (337.5 lbf)
X	30 mm (1.1811 in)
Speed	2000 min <sup>-1</sup>
Rating fatigue life	≈ 2943 h

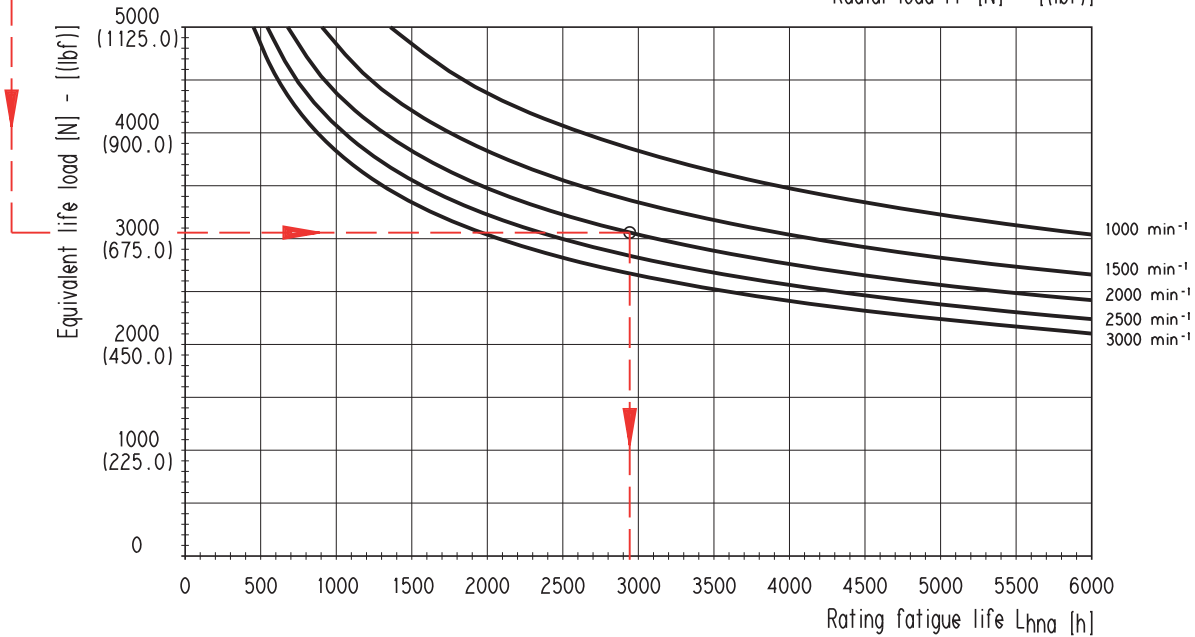
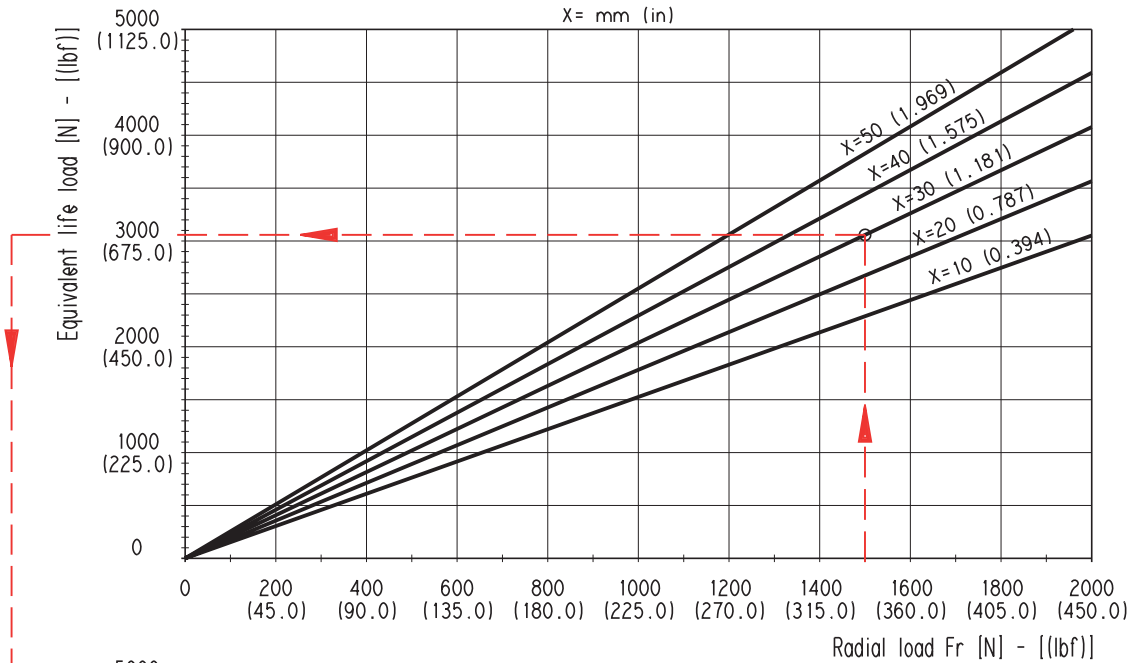

D010-150/0605

01/07.2005

## DRIVE SHAFTS

### SAE "B" SPLINE

04

Mounting face refer to flange code **S3**

Ext. Involute Spline SAE J498B  
with major diameter modified  
13 teeth - 16/32 Pitch - 30 deg  
Flat Root - Side fit - Class 1

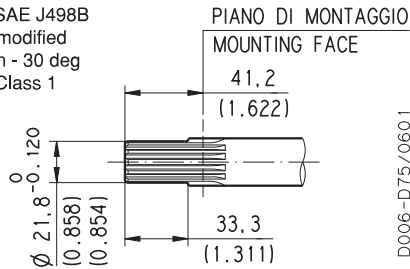

**HD. 30** MAX 330 Nm (2921 lbf in) ◆

**HD. 35** MAX 300 Nm (2655 lbf in) ◆

### SAE "B" STRAIGHT

32

Mounting face refer to flange code **S3**

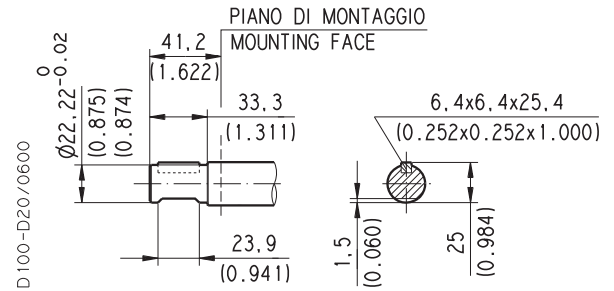

**MAX 200 Nm (1770 lbf in) ◆**

### SAE "BB" SPLINE

05

Mounting face refer to flange code **S3**

Ext. Involute Spline SAE J498B  
with major diameter modified  
15 teeth - 16/32 Spline - 30 deg  
Flat Root - Side fit - Class 1

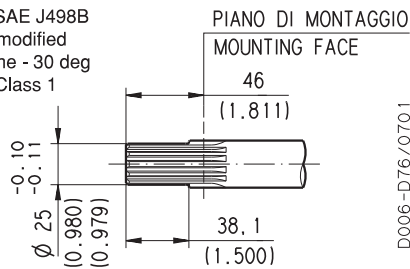

**HD. 30** MAX 500 Nm (4426 lbf in) ◆

**HD. 35** MAX 450 Nm (3983 lbf in) ◆

### SAE "BB" STRAIGHT

33

Mounting face refer to flange code **S3**

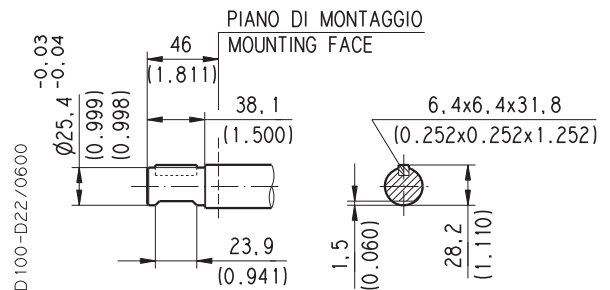

**MAX 280 Nm (2478 lbf in) ◆**

### SAE "C" SPLINE

06

Mounting face refer to flange code **S8**

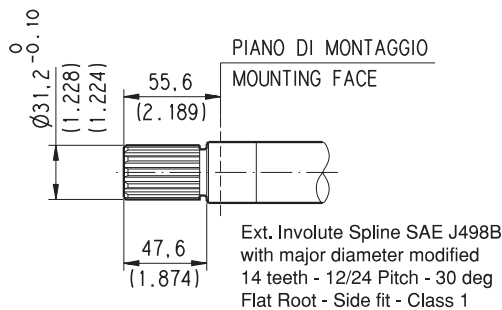

**HD. 30** MAX 170 Nm (1505 lbf in) ◆

**HD. 35** MAX 900 Nm (7966 lbf in) ◆

### SAE "C" STRAIGHT

34

Mounting face refer to flange code **S8**

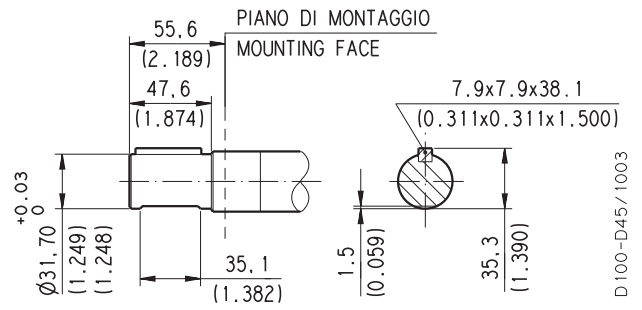

**MAX 600 Nm (5311 lbf in) ◆**

01/07.2005

◆ For "2", "3" and "4" version whichever end shaft, the max torque applicable is:  
HD. 30 MAX 170 Nm (1505 lbf in) - HD. 35 MAX 350 Nm (3098 lbf in)

## MOUNTING FLANGES AND TABLE OF COMPATIBILITY

### SAE "A" 2 HOLES

**S1**

Conforms to SAE J744

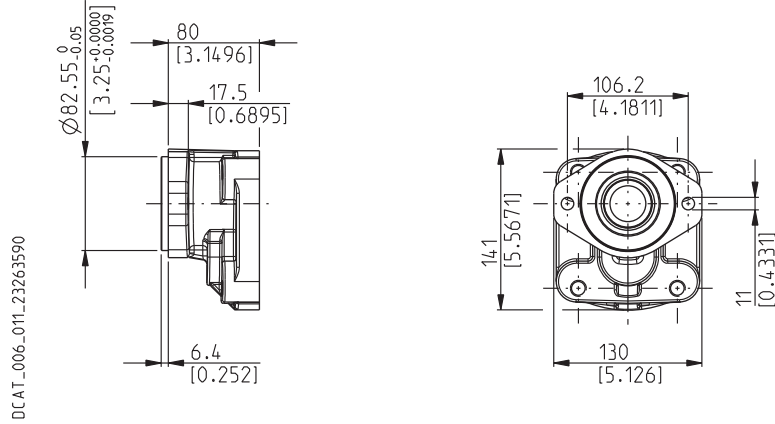

#### DRIVE SHAFTS See page 47

GROUP	VERSIONS See page 42	04	32	05	33	06	34
<b>HD. 30</b>	<b>0</b>	X	X	X	X		
	<b>1</b>	X	X	X	X		
	<b>2</b>	X	X	X	X	X	X

X Available combination

### SAE "B" 2-4 HOLES

**S3**

Conforms to SAE J744

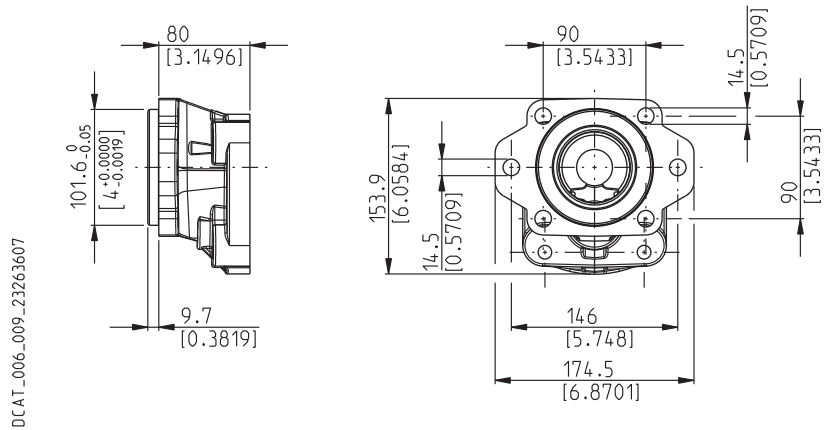

#### DRIVE SHAFTS See page 47

GROUP	VERSIONS See page 42	04	32	05	33	06	34
<b>HD. 30</b>	<b>0</b>	X	X	X	X		
	<b>1</b>	X	X	X	X		
	<b>2</b>	X	X	X	X	X	X
	<b>3</b>	X	X	X		X	X
	<b>4</b>	X	X		X	X	X

X Available combination

01/07.2005

## MOUNTING FLANGES AND TABLE OF COMPATIBILITY

SAE "C" 2-4 HOLES

**S8**

Conforms to SAE J744

Replaces: 01/07.2005

D010-D10/0505

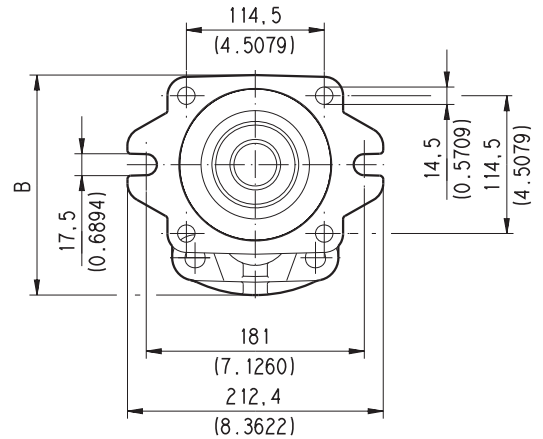
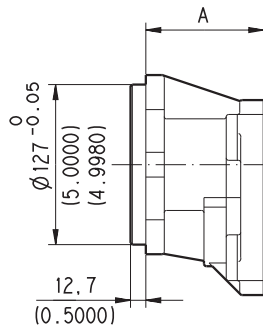

GROUP	A	B
	mm (inch)	mm (inch)
<b>HD. 30</b>	80 (3.1496)	167,9 (6.6102)
<b>HD. 35</b>	90 (3.5433)	182,8 (7.1969)

**DRIVE SHAFTS**  
See page 47

○

GROUP	VERSIONS See page 42	DRIVE SHAFTS					
		04	32	05	33	06	34
<b>HD. 30</b>	<b>0</b>	X	X	X	X		
	<b>1</b>	X	X	X			
	<b>2</b>	X	X	X	X	X	X
	<b>3</b>	X	X	X		X	X
	<b>4</b>	X	X		X	X	X
<b>HD. 35</b>	<b>0</b>					X	X
	<b>1</b>					X	X
	<b>2</b>	X	X	X	X	X	X
	<b>3</b>					X	X
	<b>4</b>	X				X	X

X Available combination

○ 02/06.2012

## MOUNTING FLANGES AND TABLE OF COMPATIBILITY

### SAE "B" 4 HOLES

**S4**

Conforms to SAE J744

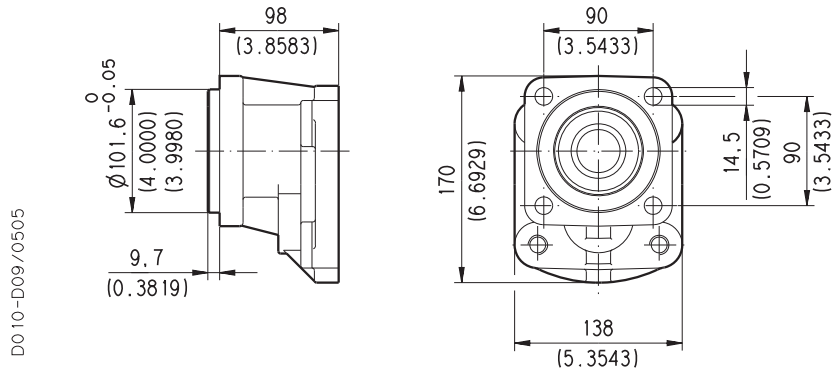

#### DRIVE SHAFTS

See page 47

GROUP	VERSIONS See page 42	04	32	05	33	06	34
<b>HD. 35</b>	<b>0</b>					X	X
	<b>1</b>					X	X
	<b>2</b>	X	X			X	X
	<b>3</b>					X	X
	<b>4</b>	X				X	X

X Available combination

### SAE "B" 2 HOLES

**S5**

Conforms to SAE J744

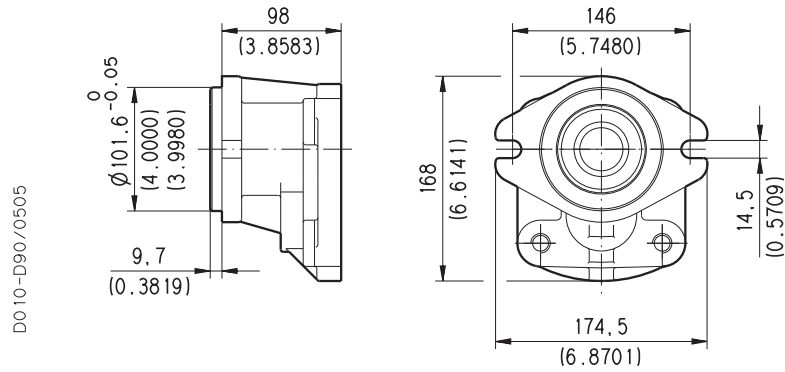

#### DRIVE SHAFTS

See page 47

GROUP	VERSIONS See page 42	04	32	05	33	06	34
<b>HD. 35</b>	<b>0</b>					X	X
	<b>1</b>					X	X
	<b>2</b>	X	X	X	X	X	X
	<b>3</b>					X	X
	<b>4</b>	X				X	X

X Available combination

01/07.2005

## PORTS TYPE

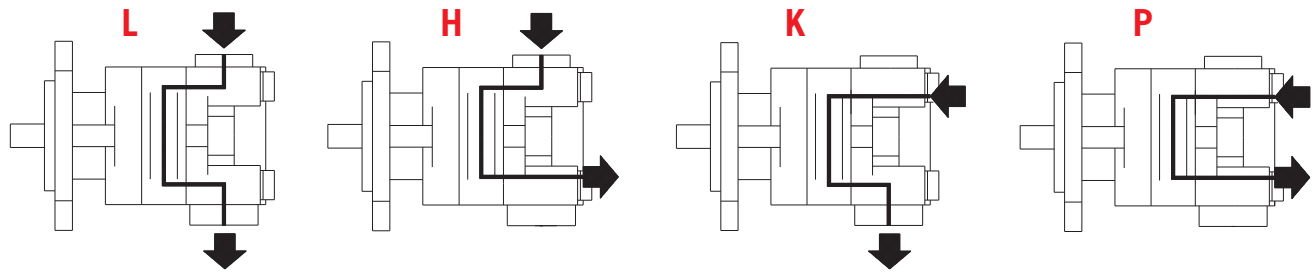

PORTS TYPE	SIDE PORTS								REAR PORTS			
	Split SSM		Spit SSS		Gas BSPP		SAE ODT		Gas BSPP		SAE ODT	
Pump type	IN	OUT	IN	OUT	IN	OUT	IN	OUT	IN	OUT	IN	OUT
Motor type	OUT	IN	OUT	IN	OUT	IN	OUT	IN	OUT	IN	OUT	IN
<b>HD. 30•17</b>	MC	MB	SC	SB	GF	GE	OF	OD	GE	GE	OD	OD
<b>HD. 30•22</b>	MC	MB	SC	SB	GF	GE	OF	OD	GE	GE	OD	OD
<b>HD. 30•27</b>	MC	MB	SC	SB	GF	GE	OF	OD	GE	GE	OD	OD
<b>HD. 30•34</b>	MC	MB	SC	SB	GF	GE	OF	OD	GE	GE	OD	OD
<b>HD. 30•38</b>	MC	MB	SC	SB	GF	GE	OF	OD	GE	GE		
<b>HD. 30•43</b>	MD	MC	SD	SC	GG	GF	OG	OF	GF (●)	GE		
<b>HD. 30•51</b>	MD	MC	SD	SC	GG	GF	OG	OF	GF (●)	GE		
<b>HD. 30•56</b>	MD	MC	SD	SC	GG	GF	OG	OF	GF (●)	GE		
<b>HD. 30•61</b>	ME	MD	SE	SD	GG	GF	OG	OF	GF (●)	GE		
<b>HD. 30•73</b>	ME	MD	SE	SD	GG	GF	OG	OF	GF (●)	GE		
<b>HD. 30•82</b>	ME	MD	SE	SD	GG	GF	OG	OF	GF (●)	GE		
<b>HD. 35•40</b>	ME	MD	SE	SD	GH	GG	OG	OF	GG (●)	GF	OF OH (◆)	OD OG (◆)
<b>HD. 35•50</b>	ME	MD	SE	SD	GH	GG	OG	OF	GG (●)	GF	OF OH (◆)	OD OG (◆)
<b>HD. 35•63</b>	ME	MD	SE	SD	GH	GG	OG	OF	GG (●)	GF	OF OH (◆)	OD OG (◆)
<b>HD. 35•71</b>	ME	MD	SE	SD	GH	GG	OG	OF	GG (●)	GF	OF OH (◆)	OD OG (◆)
<b>HD. 35•80</b>	ME	MD	SE	SD	GH	GG	OG	OF	GG (●)	GF	OF OH (◆)	OD OG (◆)
<b>HD. 35•90</b>	MF	ME	SF	SE	GL	GH	OH	OG	GG (●)	GF		
<b>HD. 35•100</b>	MF	ME	SF	SE	GL	GH	OH	OG	GG (●)	GF		
<b>HD. 35•112</b>	MF	ME	SF	SE	GL	GH	OH	OG				
<b>HD. 35•125</b>	MF	ME	SF	SE	GL	GH	OH	OG				

01/07.2005

(●) Not available for reversible pumps and motors with external drain.

(◆) Available only for single pumps with larger ports.

## EXTERNAL DRAIN PORTS HD. 30 E HD. 35

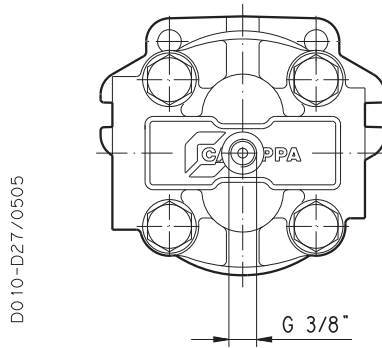

Rear port for reversible pumps and motors with external drain (R).  
For dimensions see page 54.

**BSPP**

## PORTS FOR MULTIPLE PUMPS

### SEPARATED INLET

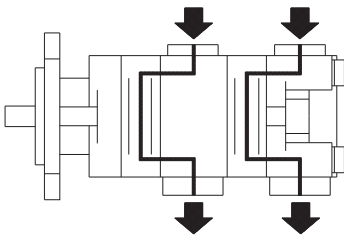

### SEPARATED STAGES

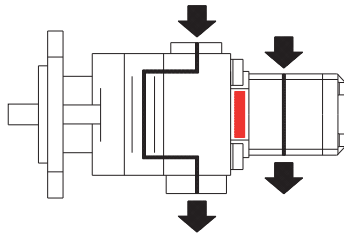

Inlet and outlet ports are the same as side ports of single pumps (see page 51).

### COMMON INLET

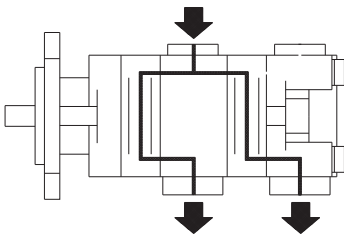

Inlet ports are larger than side inlet ports of single pumps (see table below).  
Outlet ports are the same as side outlet ports of single pumps (see page 51).

### SIDE PORTS

PORTS TYPE	Split SSM	Spit SSS	Gas BSPP	SAE ODT
Pump type	IN	IN	IN	IN
<b>HDP 30</b>	ME	SE	GG	OG
<b>HDP 35</b>	MF	SF	GL	OH

01/07.2005

## PORTS SIZE



 Tightening torque for low pressure side port

 Tightening torque for high pressure side port [values obtained at 5075 psi (350 bar)]

For reversible rotation, please consult only the tightening torque for high pressure side port

### SAE FLANGED PORTS J518 - Standard pressure series 3000 PSI **SSM**

Metric thread ISO 60° conforms to ISO/R 262

CODE	A	B	C	D		
	mm (in)	mm (in)	mm (in)	Thread Depth mm (in)	Nm (lbf in)	Nm (lbf in)
<b>MB</b>	19 (0.7480)	47,6 (1.8740)	22,2 (0.8740)	M 10 22 (0.8661)	20 <sup>+1</sup> (177 ÷ 186)	35 <sup>+2,5</sup> (310 ÷ 332)
<b>MC</b>	24,5 (0.9646)	52,4 (2.0630)	26,2 (1.0315)	M 10 22 (0.8661)	20 <sup>+1</sup> (177 ÷ 186)	35 <sup>+2,5</sup> (310 ÷ 332)
<b>MD</b>	30,5 (1.2008)	58,7 (2.3110)	30,2 (1.1890)	M 10 22 (0.8661)	20 <sup>+1</sup> (177 ÷ 186)	35 <sup>+2,5</sup> (310 ÷ 332)
<b>ME</b>	39,3 (1.5472)	69,8 (2.7480)	35,7 (1.4055)	M 12 27 (1.0630)	30 <sup>+2,5</sup> (266 ÷ 288)	65 <sup>+5</sup> (575 ÷ 620)
<b>MF</b>	51 (2.0079)	77,8 (3.0630)	42,9 (1.6890)	M 12 27 (1.0630)	30 <sup>+2,5</sup> (266 ÷ 288)	—

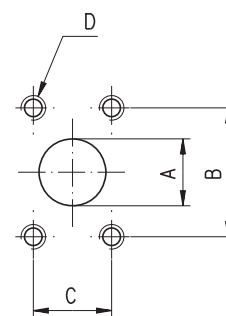

D010-D15/0405



### SAE FLANGED PORTS J518 - Standard pressure series 3000 PSI **SSS**

American straight thread UNC-UNF 60° conforms to ANSI B 1.1

01/07.2005

CODE	A	B	C	D		
	mm (in)	mm (in)	mm (in)	Thread Depth mm (in)	Nm (lbf in)	Nm (lbf in)
<b>SB</b>	19 (0.7480)	47,6 (1.8740)	22,2 (0.8740)	3/8 - 16 UNC-2B 22 (0.8661)	20 <sup>+1</sup> (177 ÷ 186)	30 <sup>+2,5</sup> (266 ÷ 288)
<b>SC</b>	24,5 (0.9646)	52,4 (2.0630)	26,2 (1.0315)	3/8 - 16 UNC-2B 22 (0.8661)	20 <sup>+1</sup> (177 ÷ 186)	30 <sup>+2,5</sup> (266 ÷ 288)
<b>SD</b>	30,5 (1.2008)	58,7 (2.3110)	30,2 (1.1890)	7/16 - 14 UNC-2B 28,5 (1.1220) 7/16 - 14 UNC-2B 27 (1.0630) (◆)	25 <sup>+1</sup> (221 ÷ 230)	55 <sup>+5</sup> (487 ÷ 531)
<b>SE</b>	39,3 (1.5472)	69,8 (2.7480)	35,7 (1.4055)	1/2 - 13 UNC-2B 27 (1.0630)	30 <sup>+2,5</sup> (266 ÷ 288)	70 <sup>+5</sup> (620 ÷ 664)
<b>SF</b>	51 (2.0079)	77,8 (3.0630)	42,9 (1.6890)	1/2 - 13 UNC-2B 27 (1.0630)	30 <sup>+2,5</sup> (266 ÷ 288)	—

D010-D15/0405

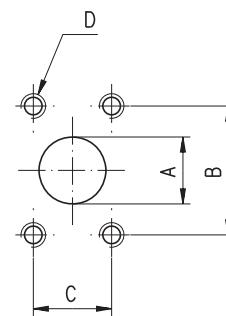

(◆) For MAGNUM 35

## PORTS SIZE



Tightening torque for low pressure side port



Tightening torque for high pressure side port [values obtained at 5075 psi (350 bar)]

For reversible rotation, please consult only the tightening torque for high pressure side port

### GAS STRAIGHT THREAD PORTS

**BSPP**

British standard pipe parallel (55°) conforms to UNI - ISO 228

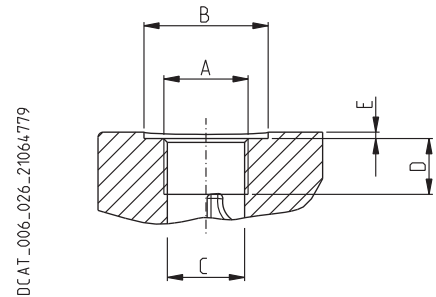

CODE	Nominal size	A	Ø B	Ø C	D	E		
			mm (in)	mm (in)	mm (in)	mm (in)	Nm (lbf in)	Nm (lbf in)
<b>GC (◆)</b>	3/8"	G 3/8	25 (0.9843)	15 (0.5906)	14 (0.5512)	4 (0.1575)	15 <sup>+1</sup> (133 ÷ 142)	—
<b>GE</b>	3/4"	G 3/4	—	24,5 (0.9646)	22 (0.8661)	—	30 <sup>+2,5</sup> (266 ÷ 288)	90 <sup>+5</sup> (797 ÷ 841)
<b>GF</b>	1"	G 1	—	30,5 (1.2008)	25 (0.9843)	—	50 <sup>+2,5</sup> (443 ÷ 465)	130 <sup>+10</sup> (1151 ÷ 1239)
<b>GG</b>	1" 1/4	G 1 1/4	—	39 (1.5354)	26 (1.0236)	—	60 <sup>+5</sup> (531 ÷ 575)	170 <sup>+10</sup> (1505 ÷ 1593)
<b>GH</b>	1" 1/2	G 1 1/2	—	45 (1.7716)	28 (1.1024)	—	70 <sup>+5</sup> (620 ÷ 664)	210 <sup>+10</sup> (1859 ÷ 1947)
<b>GL</b>	2"	G 2	—	57 (2.2441)	32 (1.2598)	—	150 <sup>+10</sup> (1328 ÷ 1416)	—

(◆) = Drain port

01/07.2005

## PORTS SIZE



Tightening torque for low pressure side port



Tightening torque for high pressure side port [values obtained at 5075 psi (350 bar)]

For reversible rotation, please consult only the tightening torque for high pressure side port

### SAE STRAIGHT THREAD PORTS J514

**ODT**

American straight thread UNC-UNF 60° conforms to ANSI B 1.1

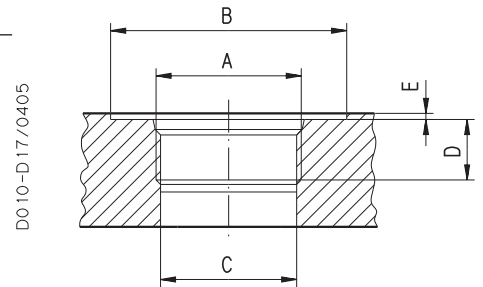

CODE	Nominal size	A	Ø B		Ø C		D	E		
			mm (in)	mm (in)	mm (in)	mm (in)				
<b>OD</b>	3/4"	1 1/16" - 12 UNF - 2B	42 (1.6535)	24,8 (0.9764)	20 (0.7874)	0,5 (0.0197)	40 <sup>+2,5</sup> (354 ÷ 376)	120 <sup>+10</sup> (1062 ÷ 1151)		
<b>OF</b>	1"	1 5/16" - 12 UNF - 2B	50 (1.9685) 45 (◆) (1.7717)	30,5 (1.2008)	20 (0.7874)	0,5 (0.0197)	60 <sup>+5</sup> (531 ÷ 575)	170 <sup>+10</sup> (1505 ÷ 1593)		
<b>OG</b>	1" 1/4	1 5/8" - 12 UNF - 2B	60 (2.3622) 58 (◆) (2.2835)	39,1 (1.5394)	20 (0.7874)	0,5 (0.0197)	70 <sup>+5</sup> (620 ÷ 664)	200 <sup>+10</sup> (1770 ÷ 1859)		
<b>OH</b>	1" 1/2	1 7/8" - 12 UNF - 2B	65 (2.5591)	45,2 (1.7795)	20 (0.7874)	0,5 (0.0197)	100 <sup>+5</sup> (885 ÷ 929)	—		

(◆) = For MAGNUM 35

01/07.2005

## CHANGING ROTATION

### Example of changing rotation: from HDP30 pump counterclockwise to clockwise

To change rotation of unidirectional pumps and motors is necessary to operate in the following way:

1. Clean the pump externally with care.
2. Loosen, and remove, the clamp bolts (1).

3. Coat the sharp edges of the drive shaft (4) with adhesive tape and smear a layer of clean grease on the shaft end extension to avoid damaging the lip of the shaft seal when removing the mounting flange.

4. Remove the mounting flange (2), taking care to keep the flange as straight as possible during removal. If the flange is stuck, tap around the edge with a fibre or rubber mallet in order to break away from the body. Ensure that while removing the front mounting flange, the drive shaft and other components remain position.

5. Ease the drive gear (4) up to facilitate removal the front plate (3), taking care that the precision ground surfaces do not become damaged, and remove the drive gear.

6. Remove the driven gear (5) without overturning. The rear plate has not to be removed.

7. Re-locate the driven gear (5) in the position previously occupied by the drive gear (4).

8. Re-locate the drive gear (4) in the position previously occupied by the driven gear (5).

9. Replace the front plate (3) in its original position.

10. Remove the grub screw (6) from the mounting flange (2) and re-locate it in the other threaded hole in the same flange.

11. Gently wipe the machined surface of the mounting flange (2) and the body with a flat hand stone.

12. Refit the front mounting flange (2) turned 180° from its original position.

13. Refit the clamp bolts (1) with the washers and tighten in a crisscross pattern to a torque value of 2230 ÷ 2726 lbf in (280<sup>±28</sup> Nm).

14. Check that the pump rotates freely when the drive shaft (4) is turned by hand. If not a pressure plate seal may be pinched.

15. The pump is ready for installation with the original rotation reversed.

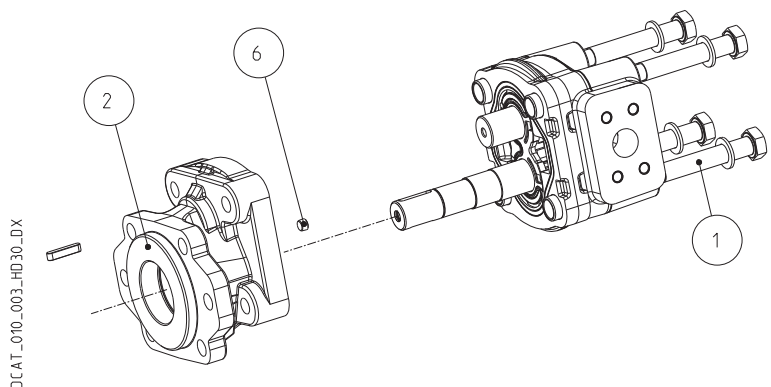
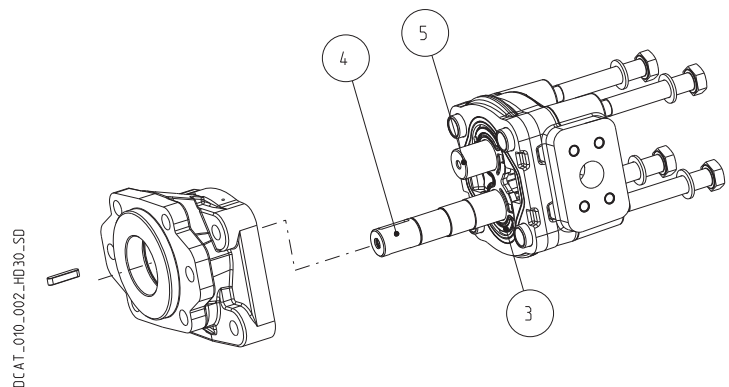
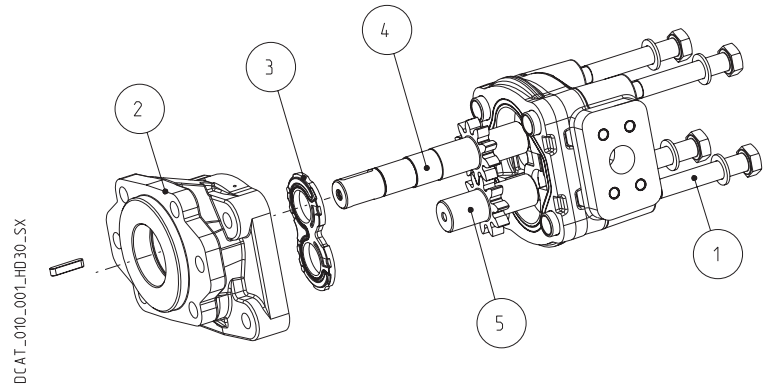

01/07.2005

---

## INSTRUCTIONS

---

### INSTALLATION

#### Pump

The direction of rotation of single-rotation pumps must be the same as that of the drive shaft. Check that the coupling flange correctly aligns the transmission shaft and the pump shaft. Flexible couplings should be used (never rigid fittings) which will not generate an axial or radial load on the pump shaft.

#### Motor

The direction of rotation of single-rotation motors must match circuit connections. Check that the coupling flange correctly aligns the transmission shaft and the motor shaft. Flexible couplings should be used (never rigid fittings) which will not generate an axial or radial load on the motor shaft.

### TANK

Tank capacity must be sufficient for the system's operating conditions ( ~ 3 times the amount of oil in circulation) to avoid overheating of the fluid. A heat exchanger should be installed if necessary. The intake and return lines in the tank must be spaced apart (by inserting a vertical divider) to prevent the return-line oil from being taken up again immediately.

### LINES

The lines must have a major diameter which is at least as large as the diameter of pump or motor ports, and must be perfectly sealed. To reduce loss of power, the lines should be as short as possible, reducing the sources of hydraulic resistance (elbow, throttling, gate valves, etc.) to a minimum. A length of flexible tubing is recommended to reduce the transmission of vibrations. All return lines must end below the minimum oil level, to prevent foaming. Before connecting the lines, remove any plugs and make sure that the lines are perfectly clean.

### FILTERS

We recommend filtering the entire system flow. Filters on suction and return line must be fitted in according to the contamination class as indicated in the first pages of the catalogue. Casappa recommends to use its own production filters:



### HYDRAULIC FLUID

Use hydraulic fluid conforming to viscosity data as specified in the first pages of the catalogue. Avoid using mixtures of different oils which could result in decomposition and reduction of the oil's lubricating power.

### STARTING UP

Check that all circuit connections are tight and that the entire system is completely clean. Insert the oil in the tank, using a filter. Bleed the circuit to assist in filling. Set the pressure relief valves to the lowest possible setting. Turn on the system for a few moments at minimum speed, then bleed the circuit again and check the level of oil in the tank. In the difference between pump or motor temperature and fluid temperature exceeds 50°F (10 °C), rapidly switch the system on and off to heat it up gradually. Then gradually increase the pressure and speed of rotation until the pre-set operating levels as specified in the catalogue are attained.

### PERIODICAL CHECKS - MAINTENANCE

Keep the outside surface clean especially in the area of the drive shaft seal. In fact, abrasive powder can accelerate wear on the seal and cause leakage. Replace filters regularly to keep the fluid clean. The oil level must be checked and oil replaced periodically depending on the system's operating conditions.

## HOW TO ORDER SINGLE UNITS

Before ordering consult shaft, flange and version table compatibility at pages 48 ÷ 50.

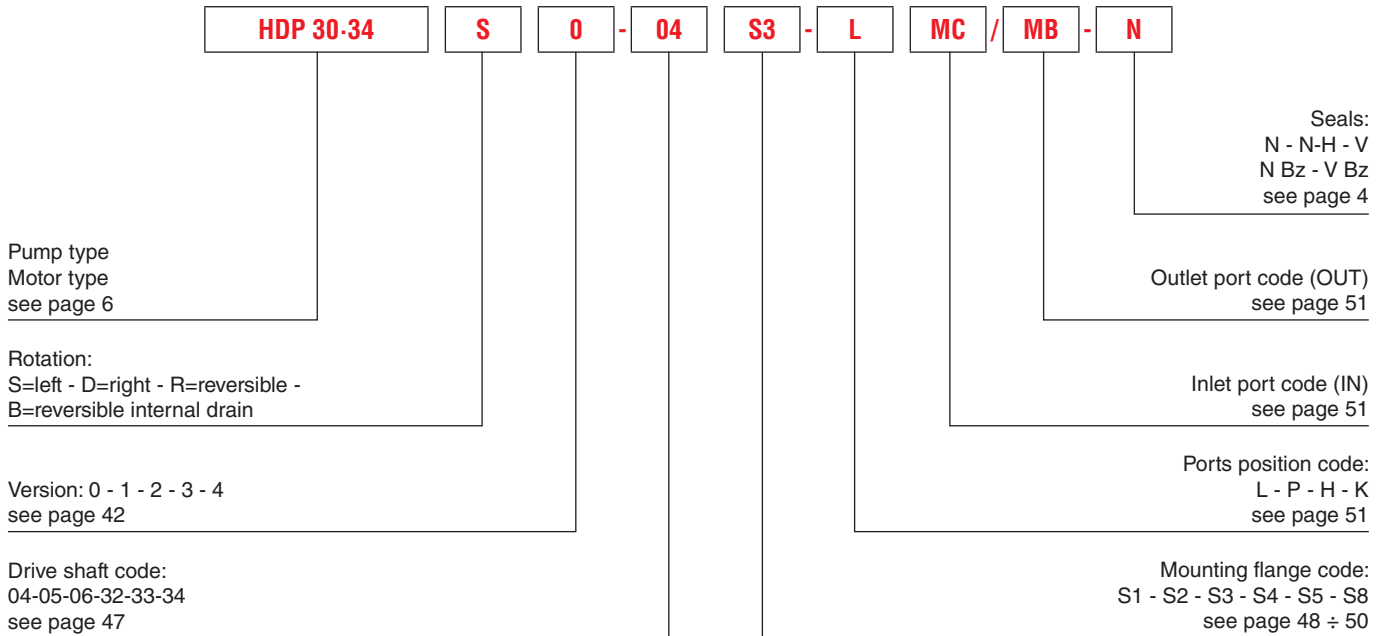

## HOW TO ORDER DOUBLE PUMPS HDP... / KP20 O PLP20

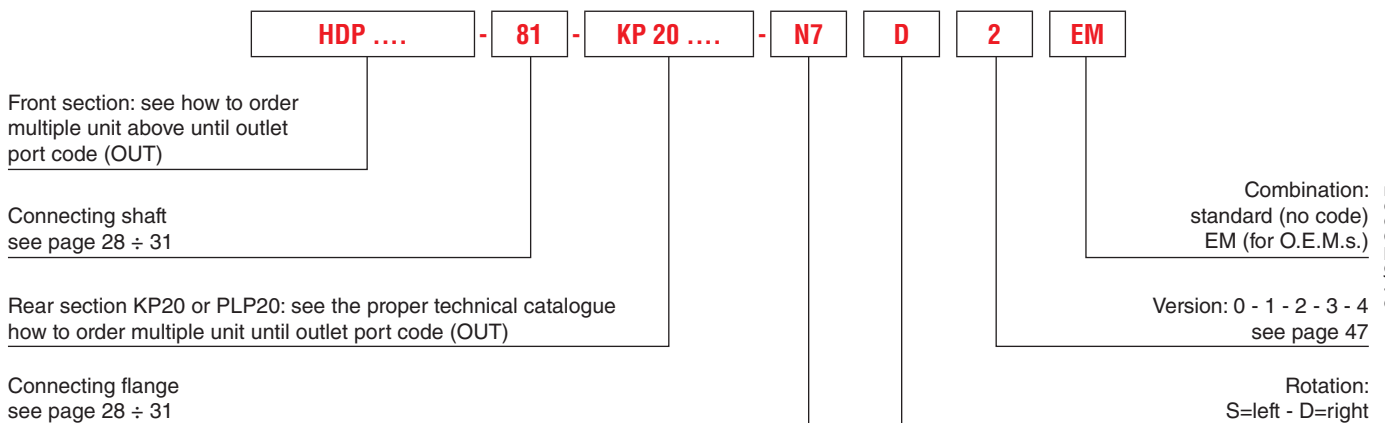

01/07.2005

## HOW TO ORDER MULTIPLE UNITS HDP... / HDP

Before ordering consult shaft, flange and version table compatibility at pages 48 ÷ 50.

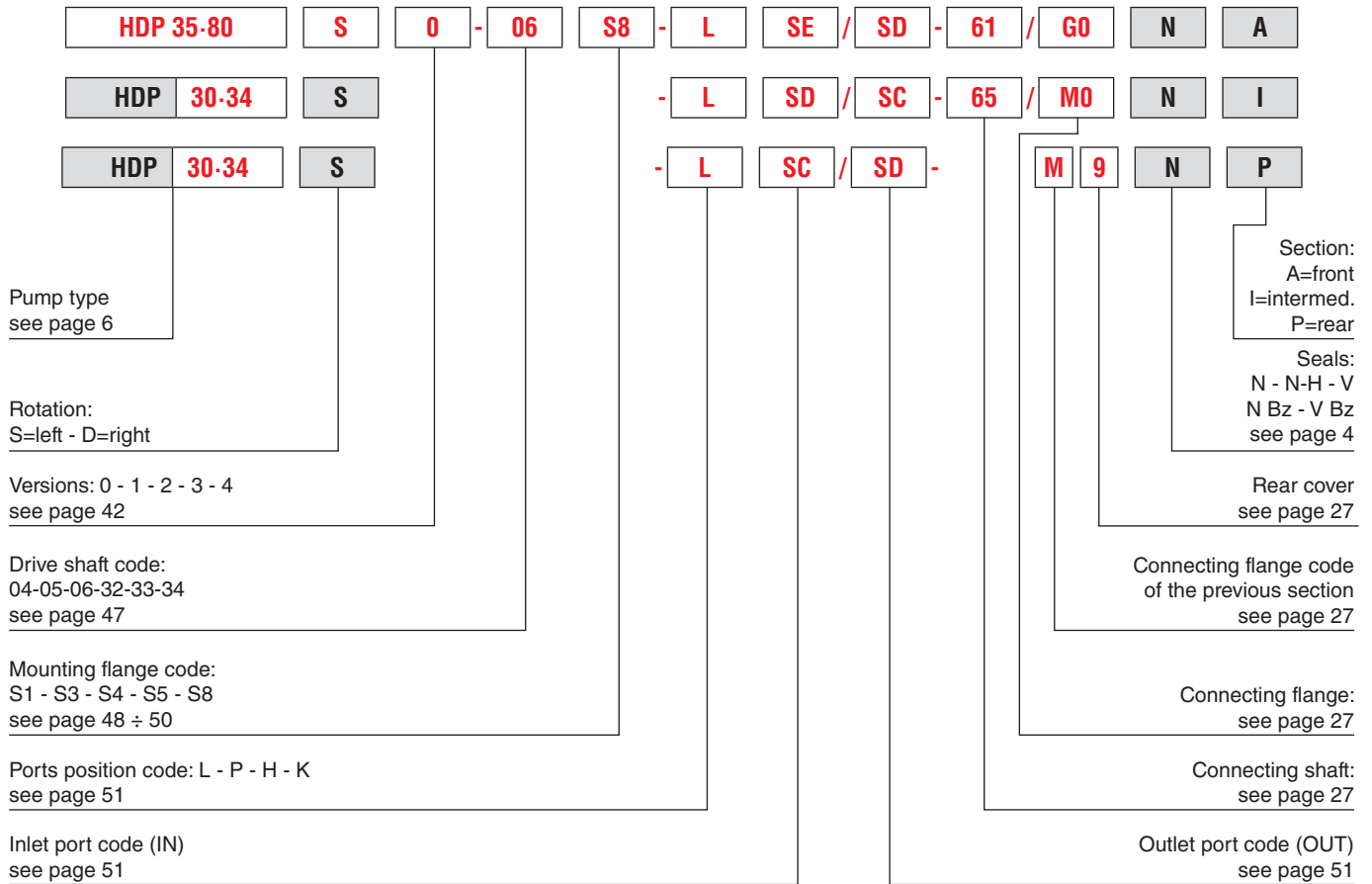

Omit code only if ordering complete multiple assembly

## MULTIPLE PUMPS ORDER EXAMPLE

Triple pump HDP 35 / 30 / 30 with common inlet between front and intermediate section.

### HOW TO ORDER SEPARATED SECTIONS



### HOW TO ORDER AN ASSEMBLED TRIPLE PUMP

**HDP 35•71-06 S6-L GL/GG / 30•34-L GF/GE-S**

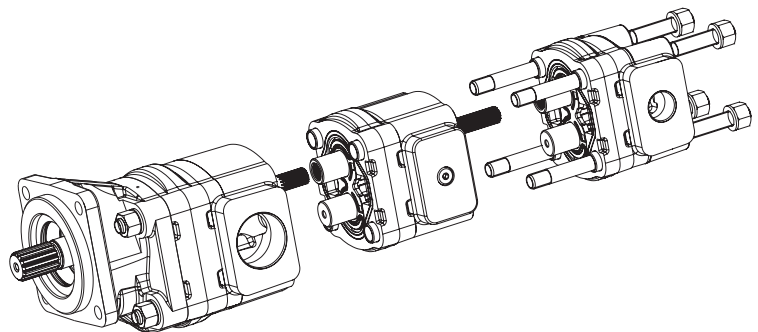

01/07.2005

Our policy is one of continuous improvement in product. Specification of items may, therefore, be changed without notice.