

# Analog In/Out Combination Module

Requires D2-250-1 or D2-262 CPU.

<b>F2-8AD4DA-1 8-Channel Analog Current Input 4-Channel Analog Current Output \$710.00</b>	
<b>Input Channels per Module</b>	8, single ended (one common)
<b>Input Range</b>	0 to 20 mA
<b>Resolution</b>	12, 14, 16-bit selectable
<b>External DC Power Required</b>	100 mA @ 18-26.4 VDC
<b>Max. Continuous Overload</b>	±45 mA
<b>Input Impedance</b>	100Ω 0.1% 1/4 W
<b>Filter Characteristics</b>	Active low pass, -3 dB @ 80 Hz
<b>Conversion Time</b>	12-bit = 1.5 ms per channel 14-bit = 6 ms per channel 16-bit = 25 ms per channel
<b>Conversion Method</b>	Over sampling successive approximation
<b>Accuracy vs. Temperature</b>	±25 ppm / °C Max.
<b>Maximum Inaccuracy</b>	0.1% of range
<b>Linearity Error (End to End)</b>	12-bit = ±2 count max. (±0.06% of range) 14-bit = ±10 count max. (±0.06% of range) 16-bit = ±20 count max. (±0.06% of range) Monotonic with no missing codes
<b>Full Scale Calibration Error (not including offset error)</b>	±0.07% of range max.
<b>Offset Calibration Error</b>	±0.03% of range max.
<b>Rec. Fuse (external)</b>	0.032A, Littelfuse Series 217 fast-acting
<b>Base Power Required 5VDC</b>	35mA

<b>Output Channels per Module</b>	4
<b>Output Range</b>	4 to 20 mA
<b>Resolution</b>	16-bit, 0.244 mA/bit
<b>Output Type</b>	Current sourcing at 20 mA, max.
<b>Load Impedance</b>	0-750 Ω
<b>Max. Inaccuracy</b>	0.25% of range
<b>Max. Full Scale Calibration Error (not incl. offset error)</b>	±0.075% of range max.
<b>Max. Offset Calibration Error</b>	±0.1% of range max.
<b>Accuracy vs. Temperature</b>	±25 ppm / °C max. full scale calibration change (± 0.0025% of range / °C)
<b>Max. Crosstalk at DC, 50/60 Hz</b>	-70 dB, 1 LSB
<b>Linearity Error (End to End)</b>	±1 count max. (±0.025% of full scale) Monotonic with no missing codes
<b>Output Stability and Repeatability</b>	±1 LSB after 10 minute warm-up typical
<b>Output Ripple</b>	0.005% of full scale
<b>Output Settling Time</b>	0.5 ms max., 5 μs, min. (full scale change)
<b>Max. Continuous Overload</b>	Outputs open circuit protected
<b>Type of Output Protection</b>	Electronically current limited to 20 mA or less
<b>Output Signal at Power-up and Power-down</b>	4 mA
<b>Terminal Type (included)</b>	Removable; D2-16IOCON

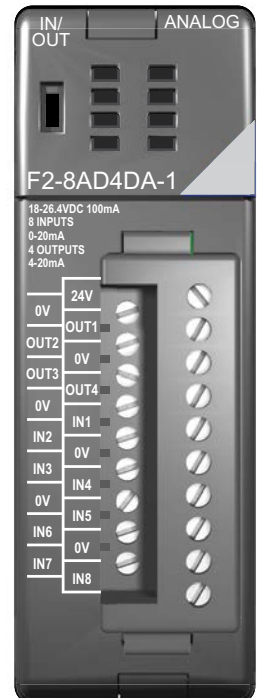
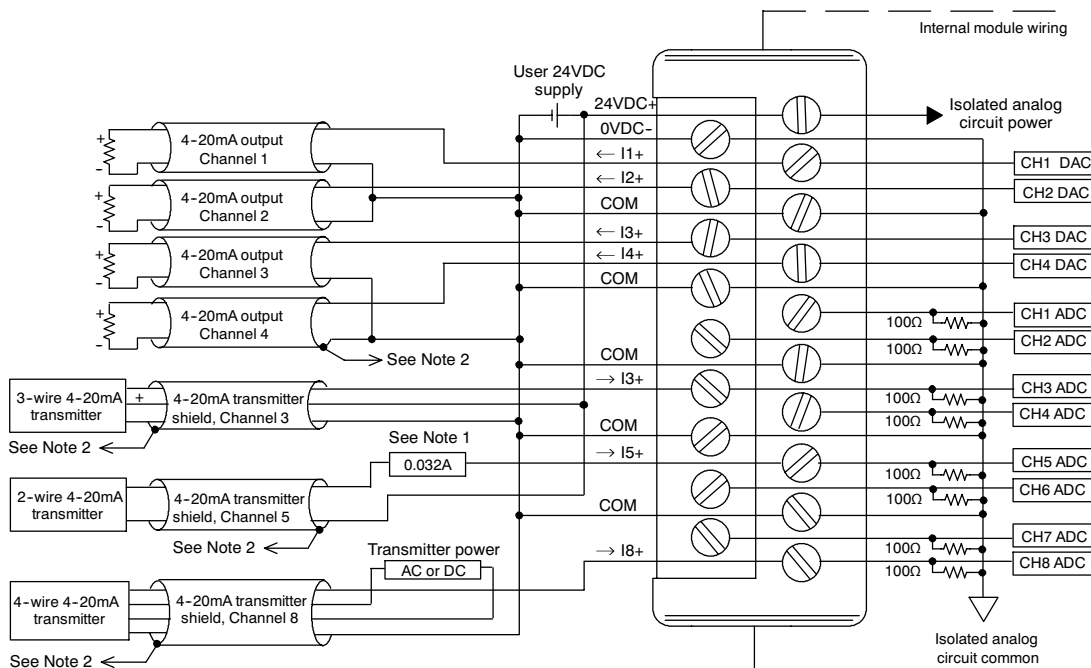

Note 1: A Littelfuse Series 217, 0.032A fast-acting fuse is recommended for all 4-20mA current loop inputs.

Note 2: Connect shields to the 0V of the module; do not connect both ends of shield.

# Wiring Solutions

## Wiring Solutions using the **ZIPLink** Wiring System

**ZIPLinks** eliminate the normally tedious process of wiring between devices by utilizing prewired cables and DIN rail mount connector modules. It's as simple as plugging in a cable connector at either end or terminating wires at only one end.

Prewired cables keep

installation clean and efficient, using half the space at a fraction of the cost of standard terminal blocks. There are several wiring

solutions available when using the **ZIPLink** System ranging from PLC I/O-to-**ZIPLink** Connector Modules that are ready for field

termination, options for connecting to third party devices, GS, DuraPulse and SureServo Drives, as well as special relay, transorb and communications modules. Pre-printed I/O-specific adhesive label strips for quick marking of **ZIPLink** modules are provided with **ZIPLink** cables. See the following solutions to help determine the best **ZIPLink** system for your application.

### **Solution 1: Do-more, DirectLOGIC, CLICK and Productivity Series I/O Modules to ZIPLink Connector Modules**

When looking for quick and easy I/O-to-field termination, a **ZIPLink** connector module used in conjunction with a prewired **ZIPLink** cable, consisting of an I/O terminal block at one end and a multi-pin connector at the other end, is the best solution.



Using the PLC I/O Modules to **ZIPLink** Connector Modules selector tables located in this section,

1. Locate your I/O module/PLC
2. Select a **ZIPLink** Module
3. Select a corresponding **ZIPLink** Cable.

### **Solution 2: Do-more, DirectLOGIC, CLICK and Productivity Series I/O Modules to 3rd Party Devices**

When wanting to connect I/O to another device within proximity of the I/O modules, no extra terminal blocks are necessary when using the **ZIPLink** Pigtail Cables. **ZIPLink** Pigtail Cables are prewired to an I/O terminal block with color-coded pigtail with soldered-tip wires on the other end.



Using the I/O Modules to 3rd Party Devices selector tables located in this section,

1. Locate your PLC I/O module
2. Select a **ZIPLink** Pigtail Cable that is compatible with your 3rd party device.

### **Solution 3: GS Series and DuraPulse Drives Communication Cables**

Need to communicate via Modbus RTU to a drive or a network of drives?

**ZIPLink** cables are available in a wide range of configurations for connecting to PLCs and SureServo, SureStep, Stellar Soft Starter and AC drives. Add a **ZIPLink** communications module to quickly and easily set up a multi-device network.

Using the Drives Communication selector tables located in this section,

1. Locate your Drive and type of communications
2. Select a **ZIPLink** cable and other associated hardware.



DL205 PLCs

tDL2-45

# Wiring Solutions

## **Solution 4: Serial Communications Cables**

**ZIPLink** offers communications cables for use with **DirectLOGIC**, **CLICK**, and **Productivity CPUs**, that can also be used with other communications devices. Connections include a 6-pin RJ12 or 9-pin, 15-pin and 25-pin D-sub connectors which can be used in conjunction with the RJ12 or D-Sub feedthrough modules.

Using the Serial Communications Cables selector table located in this section,

1. Locate your connector type
2. Select a cable.



## **Solution 5: Specialty ZIPLink Modules**

For additional application solutions, **ZIPLink** modules are available in a variety of configurations including stand-alone relays, 24 VDC and 120 VAC transorb modules, D-sub, RJ12 and RJ45 feedthrough modules, communication port adapter and distribution modules, and SureServo 50-pin I/O interface connection.

Using the **ZIPLink** Specialty Modules selector table located in this section,

1. Locate the type of application
2. Select a **ZIPLink** module.



## **Solution 6: ZIPLink Connector Modules to 3rd Party Devices**

If you need a way to connect your device to terminal blocks without all that wiring time, then our pigtail cables with color-coded soldered-tip wires are a good solution. Used in conjunction with any compatible **ZIPLink** Connector Modules, a pigtail cable keeps wiring clean and easy and reduces troubleshooting time.

Using the Universal Connector Modules and Pigtail Cables table located in this section,

1. Select module type
2. Select the number of pins
3. Select cable.



# PLC I/O Modules to ZIPLink Connector Modules – Do-more!/DL205

Do-more / DL205 PLC Input Module ZIPLink Selector				
PLC	ZIPLink			
Input Module	# of Terms	Component	Module Part No.	Cable Part No. †
D2-08ND3	10	Feedthrough	ZL-RTB20 (-1)	ZL-D2-CBL10 *
D2-16ND3-2	19	Feedthrough		ZL-D2-CBL19
		Sensor	ZL-LTB16-24-1	ZL-D2-CBL19-1 ZL-D2-CBL19-2
D2-32ND3 1	40	Feedthrough	ZL-RTB40 (-1)	180 deg conn: ZL-D24-CBL40
		Sensor	ZL-LTB32-24-1	ZL-D24-CBL40-1 ZL-D24-CBL40-2
D2-32ND3-2 1	40	Feedthrough	ZL-RTB40(-1)	45 deg conn: ZL-D24-CBL40-X ZL-D24-CBL40-1X ZL-D24-CBL40-2X
		Sensor	ZL-LTB32-24-1	
D2-08NA-1	10	Feedthrough	ZL-RTB20 (-1)	ZL-D2-CBL10
D2-08NA-2	10			ZL-D2-CBL10-1
D2-16NA	19			ZL-D2-CBL10-2
				ZL-D2-CBL19 *

† X in the part number represents a 45° angle.

Do-more/DL205 PLC Combo In/Out Module ZIPLink Selector				
PLC	ZIPLink			
Combo Module	# of Terms	Component	Module Part No.	Cable Part No.
D2-08CDR	10	Feedthrough	ZL-RTB20 (-1)	ZL-D2-CBL10 *

Do-more/DL205 PLC Analog Module ZIPLink Selector					
PLC	ZIPLink				
Analog Module	# of Terms	Component	Module	Cable	
F2-04AD-1	10	Feedthrough	ZL-RTB20 (-1)	ZL-D2-CBL10 ZL-D2-CBL10-1 ZL-D2-CBL10-2	
F2-08AD-1					
F2-04AD-2					
F2-08AD-2					
F2-02DA-1					
F2-02DAS-1					
F2-08DA-1					
F2-02DA-2					
F2-02DAS-2					
F2-08DA-2					
F2-4AD2DA					
F2-8AD4DA-1				19	ZL-D2-CBL19 ZL-D2-CBL19-1 ZL-D2-CBL19-2
F2-8AD4DA-2					
F2-04RTD				Matched Only	These modules are not supported by the ZIPLink wiring system
F2-04THM					

Do-more/ DL205 PLC Output Module ZIPLink Selector				
PLC	ZIPLink			
Output Module	# of Terms	Component	Module Part No.	Cable Part No. †
D2-04TD1 2	10	Feedthrough	ZL-RTB20 (-1)	ZL-D2-CBL10
D2-08TD1				ZL-D2-CBL10-1
D2-08TD2				ZL-D2-CBL10-2
D2-16TD1-2	19	Feedthrough	ZL-RTB20 (-1)	ZL-D2-CBL19 ZL-D2-CBL19-1 ZL-D2-CBL19-2
		Fuse		
Feedthrough		ZL-RFU20 4		
Relay		ZL-RRL16-24-2 ZL-RRL16W-24-2 ZL-RRL16F-24-2 ZL-RRL16HDF-24-2		
F2-16TD1P	19	Feedthrough	ZL-RTB20 (-1)	
F2-16TD2P				
D2-32TD1 1	40	Feedthrough	ZL-RTB40 (-1)	180 deg conn: ZL-D24-CBL40 ZL-D24-CBL40-1 ZL-D24-CBL40-2 45 deg conn: ZL-D24-CBL40-X ZL-D24-CBL40-1X ZL-D24-CBL40-2X
		Fuse	ZL-RFU40 4	
		Feedthrough	ZL-RTB40 (-1)	
Fuse		ZL-RFU40 4		
D2-08TA	10	Feedthrough	ZL-RTB20 (-1)	ZL-D2-CBL10
F2-08TA				ZL-D2-CBL10-1 ZL-D2-CBL10-2
D2-12TA	19	Feedthrough	ZL-RFU20 4	ZL-D2-CBL19
		Fuse		ZL-D2-CBL19-1 ZL-D2-CBL19-2
D2-04TRS 2	10	Feedthrough	ZL-RTB20 (-1)	ZL-D2-CBL10
D2-08TR				ZL-D2-CBL10-1 ZL-D2-CBL10-2
F2-08TRS 2				ZL-D2-CBL19 *
F2-08TR 3	10	Feedthrough		ZL-D2-CBL10 *
D2-12TR	19	Feedthrough	ZL-RFU20 4	ZL-D2-CBL19
		Fuse		ZL-D2-CBL19-1 ZL-D2-CBL19-2

† X in the part number represents a 45° angle plug

\* Select the cable length by replacing the \* with: Blank = 0.5m, -1 = 1.0m, or -2 = 2.0m.

- To make a custom cable for the 32-point modules, use: Solder-style 180° connector ZL-D24-CON or Solder-style 45° connector ZL-D24-CON-X
- Caution: The D2-04TD1, D2-04TRS, and F2-08TRS outputs are derated not to exceed module specs 2A per point and 2A per common when used with the ZIPLink wiring system.
- The F2-08TR outputs are derated not to exceed 2A per point and 4A per common when used with the ZIPLink wiring system.
- Fuses (5 x 20mm) are not included. See Edison Electronic Fuse section for (5 x 20mm) fuse. S506 and GMA electronic circuit protection for fast-acting maximum protection. S506 and GMC electronic circuit protection for time-delay performance. Ideal for inductive circuits. To ensure proper operation, do not exceed the voltage and current rating of ZIPLink module. ZL-RFU20 = 2A per circuit; ZL-RFU40 = 400 mA per circuit.



**Note:** ZIPLink Connector Module specifications follow the Compatibility Matrix tables. ZIPLink Cables specifications are at the end of this ZIPLink section.



# Dimensions and Installation

Understanding the installation requirements for your DL205 system will help ensure that the DL205 products operate within their environmental and electrical limits.

## Plan for safety

This catalog should never be used as a replacement for the user manual. The user manual, D2-USER-M (downloadable online), contains important safety information that must be followed. The system installation should comply with all appropriate electrical codes and standards.

## Environmental specifications

The Environmental Specifications table at the right lists specifications that apply globally to the DL205 system (CPUs, bases, and I/O modules). Be sure that the DL205 system is operated within these environmental specifications.

## Base dimensions and mounting

Use the diagrams below to make sure the DL205 system can be installed in your application. To ensure proper airflow for cooling purposes, DL205 bases must be mounted horizontally. It is important to check these dimensions against the conditions required for your application. For example, it is recommended that approximately 3" of space is left in front PLC surface for ease of access and cable clearances. Also, check the installation guidelines for recommended cabinet clearances.

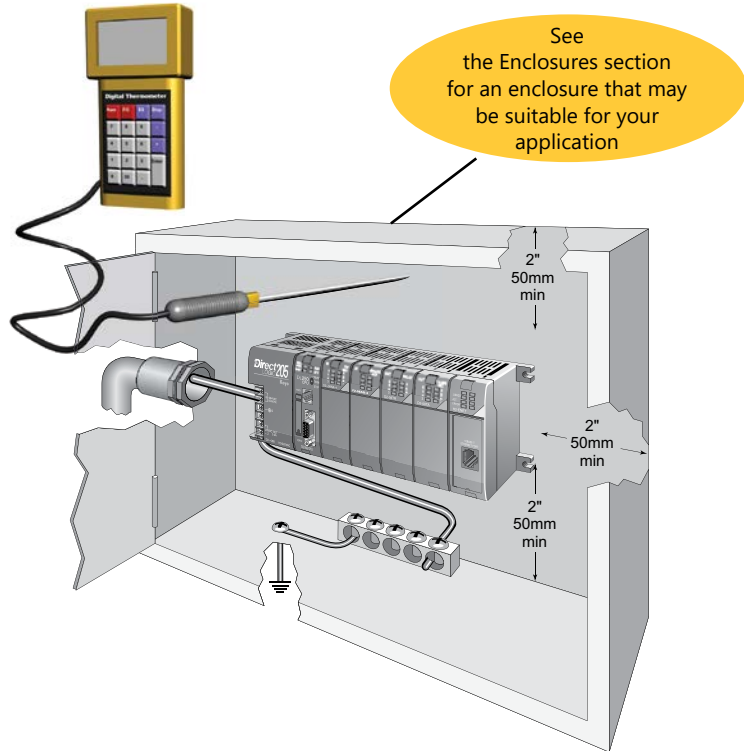

Environmental Specification	Rating
<b>Storage Temperature</b>	-4 to +158 °F (-20 to +70 °C)
<b>Ambient Operating Temperature</b>	32 to 131 °F (0 to 55 °C)
<b>Ambient Humidity</b>	30% to 95% relative humidity (non-condensing)
<b>Vibration Resistance</b>	MIL STD 810C, Method 514.2
<b>Shock Resistance</b>	MIL STD 810C, Method 516.2
<b>Noise Immunity</b>	NEMA (ICS3-304)
<b>Atmosphere</b>	No corrosive gases

Base	A	B	C	D
<b>D2-03B-1, D2-03BDC1-1</b>	6.77" 172mm	6.41" 163mm	5.8" 148mm	7.24" 184mm
<b>D2-04B-1, D2-04BDC1-1</b>	7.99" 203mm	7.63" 194mm	7.04" 179mm	8.46" 215mm
<b>D2-06B-1, D2-06BDC1-1, D2-06BDC2-1</b>	10.43" 265mm	10.07" 256mm	9.48" 241mm	10.90" 277mm
<b>D2-09B-1, D2-09BDC1-1, D2-09BDC2-1</b>	14.09" 358mm	13.74" 349mm	13.14" 334mm	14.56" 370mm

