

Durair II

by DURAVALVE

PNEUMATIC ACTUATORS



Rack & Pinion Design
for Rotary Valves



Durair II PNEUMATIC ACTUATORS

Features

EXTENDED CYCLE LIFE

(1 million cycles)

- Low Friction Bearings
- Polished Bore
- Precision Machined Gears
- Epoxy Coated Springs
- Dry or Lubricated Air

EXTERIOR COATINGS

- Tested to ASTM B117-73 (500 hrs. salt spray)
- Anodized body (ASTM 6063) or nickel plated
- End covers; epoxy-polyester coated or nickel plated



MOUNTING STYLES

- NAMUR dimensions for accessories
- ISO dimensions for valve mounting
- Shaft variations available for direct mounting
- Female star drive output shaft
- Independent travel stops $\pm 4^\circ$ each direction

SAFETY

- Precompressed spring cartridge
- Blowout proof shaft
- Visual indicator

Specifications

PERFORMANCE CHARACTERISTICS

	Model																							
	AP032		AP050		AP063		AP075		AP085		AP100		AP115		AP125		AP145		AP160		AP200		AP270	
	DA	SR	DA	SR	DA	SR	DA	SR	DA	SR	DA	SR	DA	SR	DA	SR	DA	SR	DA	SR	DA	SR	DA	SR
Volume (cu.-in.)	2.3	-	7.0	-	14.0	-	19.0	-	30.0	-	55.0	-	87.0	-	113	-	150	-	244	-	434	-	678	-
Speed (seconds)																								
to open	0.5	-	0.6	0.6	0.6	0.7	0.6	0.7	0.6	0.7	0.8	1.1	0.9	1.2	1.1	1.3	1.1	1.4	1.3	2.1	3.6	4.6	4.5	6.0
to close	0.5	-	0.6	0.6	0.7	0.9	0.7	1.0	0.9	1.3	0.9	1.3	1.1	1.6	1.1	2.1	1.4	2	1.6	2.6	4.6	6.1	4.5	6.0
Weight (lbs.)	0.92	-	2.35	2.64	3.5	4.0	6.4	7.4	9.3	10.7	12.8	15.0	20.5	23.0	26.5	31.5	34.0	42.0	45.0	55.0	95.0	117	207	249

SPECIFICATIONS

- Operating Pressure: 40 to 120 psig
- Temperature (normal operating): - 4° F to 180° F
- Media: Dry or lubricated air;
non-corrosive and inert gas;
light hydraulic oil
- Lubrication: Factory lubricated for normal lifetime
- Rotation: 90°



ACCESSORIES

- Limit Switch
- Positioner
- Solenoid Valve

All are factory installed and tested to manufacturer's specification.

Durair II PNEUMATIC ACTUATORS

TORQUE RATING - DOUBLE ACTING

Model	Air Supply in PSI							
	40	50	60	70	80	90	100	120
	Torque Value (in. - lbs.)							
AP 032	30	38	46	53	61	69	76	91
AP 050	75	94	113	131	150	169	188	225
AP 063	133	167	200	234	267	300	334	400
AP 075	285	356	428	499	570	641	712	855
AP 085	434	542	650	759	867	975	1084	1300
AP 100	675	844	1013	1182	1351	1520	1689	2027
AP 115	1115	1393	1672	1950	2229	2508	2786	3344
AP 125	1466	1833	2199	2565	2932	3299	3665	4398
AP 145	2128	2661	3193	3725	4257	4789	5321	6386
AP 160	2883	3604	4325	5045	5766	6487	7208	8649
AP 200	5406	6757	8109	9460	10812	12164	13515	16218
AP 270	13239	16548	19858	23168	26478	29788	33098	39717

OPERATION

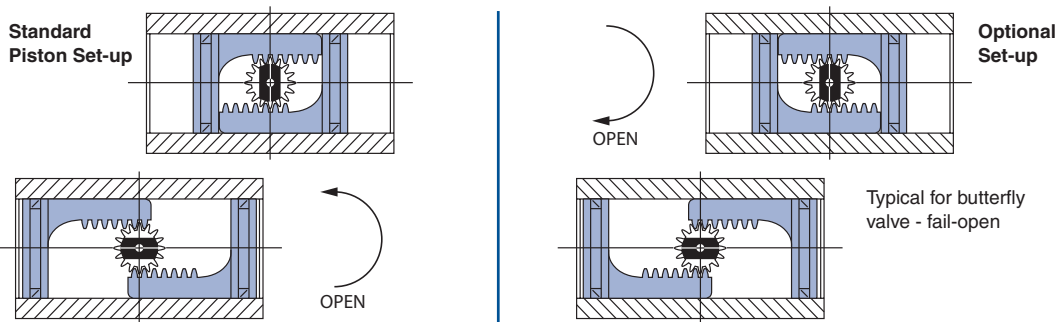

Double Acting (Top View)

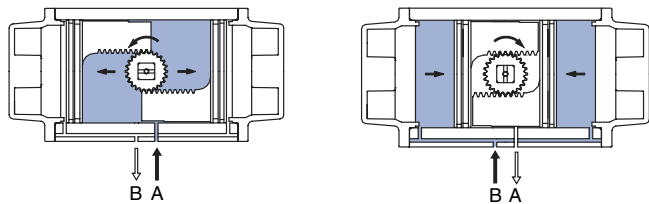

Air supplied to Port A forces pistons apart and toward end positions with exhaust air exiting at Port B (a counter-clockwise rotation is obtained).

Air supplied to Port B forces pistons toward center with exhaust air exiting at Port A (A clockwise rotation is obtained).

Spring Return (Top View)

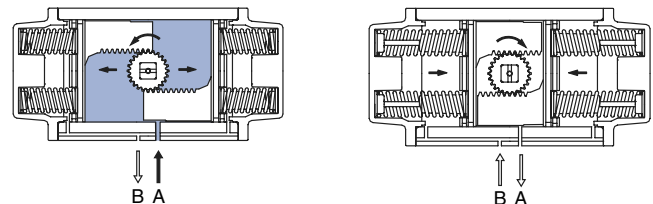

Air supplied to Port A forces pistons apart and toward end position, compressing springs. Exhaust air exits at Port B (A counter-clockwise rotation is obtained).

Air or electric failure allows springs to force pistons toward center position with exhaust air exiting at Port A (A clockwise rotation is obtained).

SPRING ARRANGEMENT

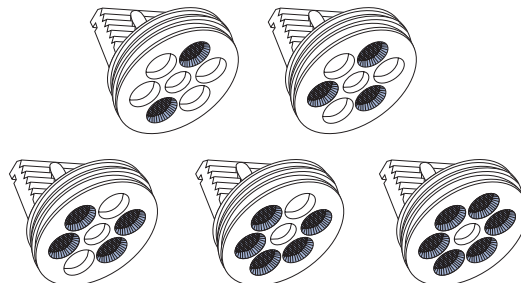

TORQUE RATING - SPRING RETURN

Model	Springs ea. side	Air Supply in PSI															
		40		50		60		70		80		90		100			
		Torque Value (in. - lbs.)															
		air start	air end	air start	air end	air start	air end	air start	air end	air start	air end	air start	air end	air start	air end	spring start	spring end
AP 050	3	44	24	63	43	82	62	100	80	119	99	138	118	157	137	51	31
	4			53	26	72	45	90	63	109	82	128	101	147	120	68	41
	5					61	28	79	46	98	65	117	84	136	103	85	52
	6							69	29	88	48	107	67	126	86	102	62
AP 063	3	78	43	112	77	145	110	179	144	212	177	245	210	279	244	90	55
	4			93	46	126	79	160	113	193	146	226	179	260	213	121	74
	5					108	49	142	83	175	116	208	149	242	183	151	92
	6							125	55	158	88	191	121	225	155	179	109
AP 075	3	174	86	245	157	317	229	388	300	459	371	530	442	601	513	199	111
	4			208	91	280	163	351	234	422	305	493	376	564	447	265	148
	5					243	96	314	167	385	238	456	309	527	380	332	185
	6							276	101	347	172	418	243	489	314	398	223
AP 085	3	267	128	375	236	483	344	592	453	700	561	808	669	917	778	306	167
	4			320	134	428	242	537	351	645	459	753	567	862	676	408	222
	5					372	141	481	250	589	358	697	466	806	575	509	278
	6							426	148	534	256	642	364	751	473	611	333
AP 100	3	410	203	579	372	748	541	917	710	1086	879	1255	1048	1424	1217	472	265
	4			490	215	659	384	828	553	997	722	1166	891	1335	1060	629	354
	5					570	227	739	396	908	565	1077	734	1246	903	786	443
	6							651	239	820	408	989	577	1158	746	943	531
AP 115	3	647	369	925	647	1204	926	1482	1204	1761	1483	2040	1762	2318	2040	746	468
	4			768	398	1047	677	1325	955	1604	1234	1883	1513	2161	1791	995	625
	5					890	428	1168	706	1447	985	1726	1264	2004	1542	1244	782
	6							1011	457	1290	736	1569	1015	1847	1293	1493	939
AP 125	3	903	432	1270	799	1636	1165	2002	1531	2369	1898	2736	2265	3102	2631	1034	563
	4			1082	455	1448	821	1814	1187	2181	1544	2548	1921	2914	2287	1378	751
	5					1259	476	1625	842	1992	1209	2359	1576	2725	1942	1723	940
	6							1436	497	1803	864	2170	1231	2536	1597	2068	1129
AP 145	3	1217	628	1750	1161	2282	1693	2814	2225	3346	2757	3878	3289	4410	3821	1500	911
	4			1447	661	1979	1193	2511	1725	3043	2257	3575	2789	4107	3321	2000	1214
	5					1675	693	2207	1225	2739	1757	3271	2289	3803	2821	2500	1518
	6							1903	725	2435	1257	2967	1789	3499	2321	3000	1822
AP 160	3	1709	913	2430	1634	3151	2355	3871	3075	4592	3796	5313	4517	6034	5238	1970	1174
	4			2038	978	2759	1699	3479	2419	4200	3140	4921	3961	5642	4582	2626	1566
	5					2368	1042	3088	1762	3809	2483	4530	3204	5251	3925	3283	1957
	6							2696	1106	3417	1827	4138	2548	4859	3269	3939	2349
AP 200	3	3261	1653	4612	3004	5964	4356	7315	5707	8667	7059	10019	8411	11370	9762	3753	2145
	4			3896	1753	5248	3105	6599	4456	7951	5808	9303	7160	10654	8511	5004	2861
	5					4534	1854	5885	3205	7237	4557	8589	5909	9940	7260	6255	3575
	6							5171	1954	6523	3306	7875	4658	9226	6009	7506	4289
AP 270	3	6943	5092	10252	8401	13562	11711	16872	15021	20182	18331	23492	21641	26802	24951	8147	6296
	4			8154	5685	11464	8995	14774	12305	18084	15615	21394	18925	24704	22235	10863	8394
	5					9366	6279	12676	9589	15986	12899	19296	16209	22606	19519	13579	10492
	6							10577	6873	13887	10183	17197	13493	20507	16803	16295	12591



Dimensional Information

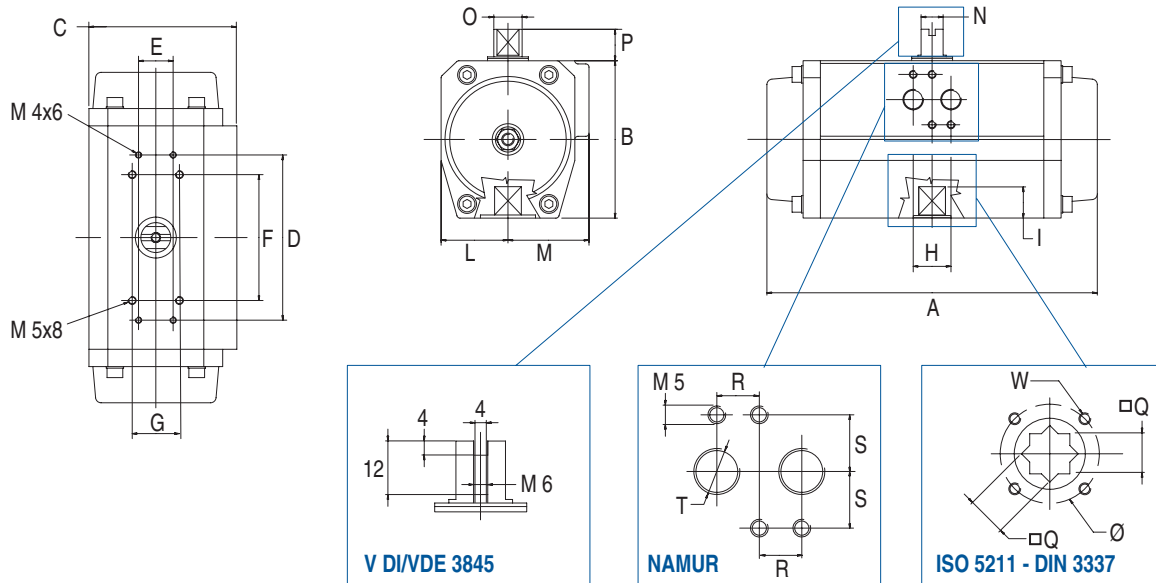

DIMENSIONS IN INCHES

Model	AP032B	AP050B	AP063B	AP075B	AP085	AP100	AP115	AP125	AP145	AP160	AP200	AP270
A	4.61	5.43	6.12	8.27	8.97	11.04	12.2	14.25	15.35	18.19	22.63	26.97
B	1.77	2.63	3.27	3.94	4.33	4.92	5.60	6.10	6.89	7.72	9.45	13.07
C	1.77	2.68	3.38	3.70	4.90	4.72	5.27	5.55	6.41	6.93	8.66	13.86
D				4.13	4.13	4.13	5.47	5.47	5.47	5.47	5.47	—
E				0.87	0.87	0.87	0.87	0.87	0.87	0.87	0.87	—
F	1.97	3.15	3.15	3.15	3.15	3.15	5.12	5.12	5.12	5.12	5.12	5.12
G	0.98	1.18	1.18	1.18	1.18	1.18	1.18	1.18	1.18	1.18	1.18	1.18
H		1.18	1.37	1.37	1.57	2.16	2.16	2.95	2.95	2.95	3.94	5.12
I	0.39	0.51	0.63	0.79	0.79	0.98	0.98	1.18	1.18	1.18	1.45	1.97
L	0.88	1.32	1.50	1.67	1.93	2.16	2.50	2.74	3.14	3.46	4.33	6.53
M	0.88	1.63	1.89	2.03	2.16	2.56	2.77	2.81	3.26	3.46	4.33	6.53
T-PORT	1/8"	1/8"	1/4"	1/4"	1/4"	1/4"	1/4"	1/4"	1/4"	1/4"	1/4"	1/2"
N	0.31	0.31	0.31	0.55	0.55	0.55	1.06	1.06	1.06	1.06	1.26	1.26
O	0.47	0.47	0.47	0.71	0.71	0.71	1.42	1.42	1.42	1.42	1.65	3.15
P	0.79	0.79	0.79	0.79	0.79	0.79	1.18	1.18	1.18	1.97	1.97	1.97
R	0.47	0.47	0.47	0.47	0.47	0.47	0.47	0.47	0.47	0.47	0.47	0.47
S	0.63	0.63	0.63	0.63	0.63	0.63	0.63	0.63	0.63	0.63	0.63	—
DIA.	1.42	1.65	1.97	1.97-2.76	1.97-2.76	2.76-4.02	2.76-4.02	2.76-4.02	4.02-4.92	4.02-4.92	5.51	6.5
Q	0.35/9mm	0.43/11mm	0.55/14mm	0.67/17mm	0.67/17mm	0.87/22mm	0.87/22mm	1.06/27mm	1.06/27mm	1.06/27mm	1.42/36mm	1.81/46mm
W*	M5	M5	M6	M6-M8	M6-M8	M8-M10	M8-M10	M8-M10	M10-M12	M10-M12	M16	M20
ISO 5211*	F03	F04	F05	F05-F07	F05-F07	F07-F10	F07-F10	F07-F10	F10-F12	F10-F12	F14	F16

Optional Mounting Patterns and/or Star Drives

Model	AP032A	AP050A	AP063A	AP075A	AP085A	AP100A		AP125A				
ISO 5211*	F04	F03	F04	F05-F07	F05-F07	F07-F10		F07-F10				
W	M5	M5	M5									
DIA.	1.65	1.42	1.65									
Q	0.35/9mm	0.35/9mm	0.43/11mm	0.55/14mm	0.55/14mm	0.55/14mm		0.87/22mm				
I	0.39	0.39	0.51	0.63	0.63	0.98		0.98				

* Actuator sizes AP075 thru AP160 have dual mounting patterns. For other possible mounting patterns contact factory.

Note: All dimensions in inches unless otherwise specified.



Materials of Construction

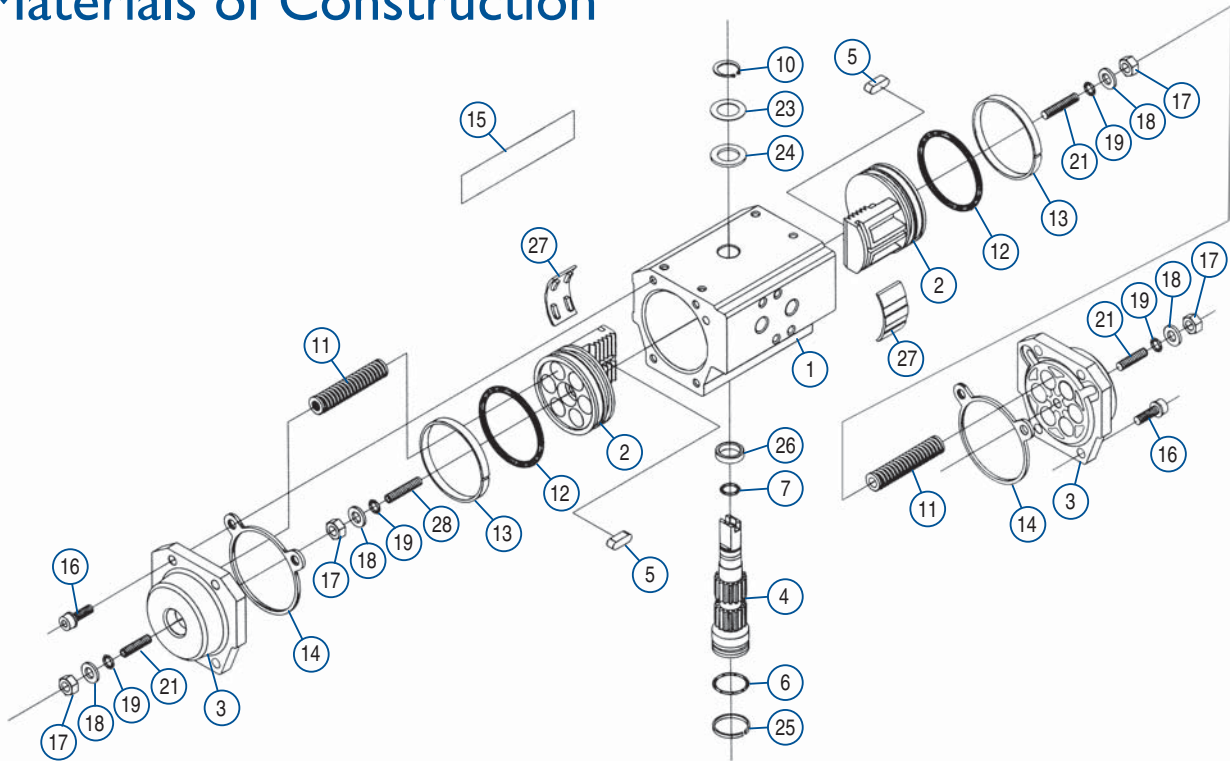

Item	Description	Material	Specifications	Qty.
1	Body	Extruded Aluminum Alloy	ASTM 6063T6	1
2	Piston	Aluminum Alloy (Die Cast)	ASTM B179	2
3	End Cover	Aluminum Alloy (Die Cast)	ASTM B179	2
4	Pinion	Steel (Nickle Plated)	ASTM A105	1
*5	Key (Pinion Anti Ejection)	Nylon		2
*6	O-Ring (Pinion, bottom)	Nitril	NBR	1
*7	O-Ring (Pinion, top)	Nitril	NBR	1
10	Retaining Ring	Spring Steel		1
11	Spring Cartridge	High Alloy Spring Steel		12 max.
12	O-Ring (Piston)	Nitrile	NBR	2
*13	Piston Bearing	Acetal Resin	LAT LUB 731 320AT +20% PTFE	2
*14	Cover Gasket	Nitrile	NBR	2
15	Nameplate	Aluminum		1
16	Cap Screw	Stainless Steel	18-8	8
17	Nut (End Stop)	Stainless Steel	18-8	4
18	Washer	Stainless Steel	18-8	4
19	O-Ring (End Stop)	Nitrile	NBR	4
21	Screw (End Stop)	Stainless Steel	18-18	2
*23	Thrust Washer (Pinion)	Stainless Steel	18-8	1
*24	Thrust Bearing	Nylon		1
*25	Bearing (Pinion, Bottom)	Nylon		1
*26	Bearing (Pinion, Top)	Nylon		1
*27	Bearing (Piston)	Nylon		2
28	Screw (Piston Stop)	Stainless Steel	18-8	2

* Spare parts kits include all the parts with asterisks(*) next to number,

Durair II PNEUMATIC ACTUATORS

DURAVALVE MANUAL AND ACTUATED VALVES

DuraValve is a quality supplier of brass and stainless steel ball valves, butterfly valves, pneumatic and electric actuators and actuated assemblies.

The DuraValve direct mount style ball valve, with it's superior stem seal design, provides long cycle life when mounted to the DurairII Pneumatic Actuator or DuraValve Electric Actuator.

DuraValve provides precision made mounting kits for non-direct mount style valves that assure proper valve to actuator alignment.

DuraValve's design provides Namur Connections for limit switches, solenoids, positioners and other accessories.

Supported by a dedicated team of highly experienced professionals, you will benefit from many years of successful industrial valve experience. DuraValve offers excellent engineering/technical support and superior customer service. DuraValve provides you with a reliable, readily available product for a broad range of operating environments, at a competitive price.



Note: The right is reserved to change or modify product design or construction without prior notice and without incurring any obligation to make such changes or modifications on products previously or subsequently sold.

DVPNEU 8-07

