

VSO1-04/R

In-line G1/4 • Q_{max} 20 l/min (5 GPM) • p_{max} 100 bar (1500 PSI)

VSO1-04/Rx-J

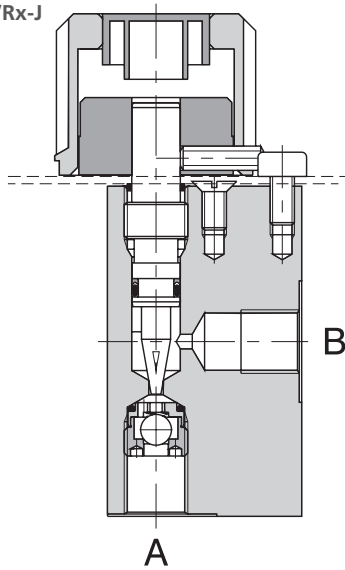

Technical Features

- › Reverse flow check option
- › Hardened precision parts
- › Fine low-torque adjustment
- › Linear adjustment and positive seat overlap
- › In the standard version, the valve body is made of aluminum, all parts are without surface treatment.

Functional Description

Hydraulic flow restrictor valve with optional by-pass or serial check valve. The adjustment sensitivity of the flow rate is determined by the selected respective seat diameter in the range between 2 and 3.5 mm.

The rotation of the hand screw is limited to just under one revolution by the hard stop on the mounting bolt. The flow rate can be adjusted within that range of rotation.

The simple fine throttle valve can be fitted with a check valve VJO1-06/SG (see datasheet 5004) installed in series. For a more unobstructed reverse flow through the valve, the model VSO1-04/Rx-O with a parallel ball valve may be used.

The connection threads in the valve body support installation in line or hose assemblies. The valve is designed to be attached on the back side of a control panel by two M6 bolts. The outer bolt with the cylindrical head functions at the same time as the hard stop for the hand screw. The attached plate for panel installation can be removed by first de-assembling the hand screw.

VSO1-04/Rx-O

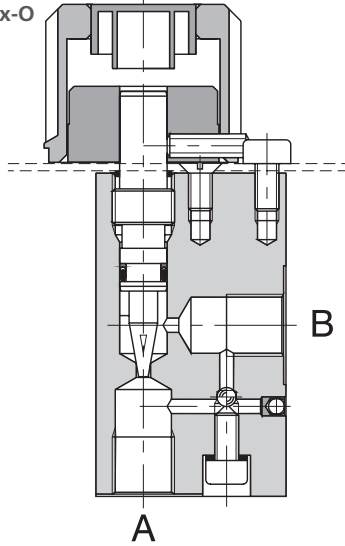

Model Code	VSO1-04/Rx	VSO1-04/Rx-J	VSO1-04/Rx-O
Symbol			

Technical Data

Valve size		In-line 04
Max. flow	l/min (GPM)	20 (5.3)
Max. operating pressure	bar (PSI)	100 (1500)
Fluid temperature range (NBR)	°C (°F)	-30 ... +100 (-22 ... +212)
Weight	kg (lbs)	0.22 (0.49)

	Datasheet	Type
General information	HA 0060	Products and operating conditions
Spare parts	HA 8010	

Dimensions in millimeters (inches)

VSO1-04/R

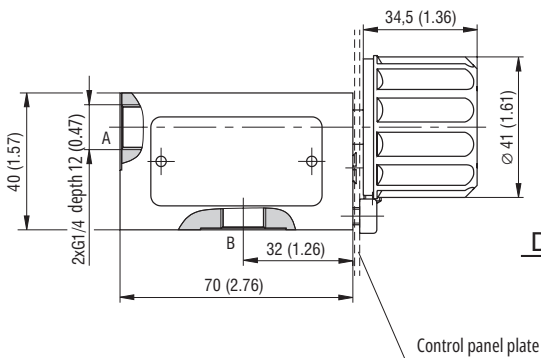

Control panel plate
Detail D - Installation dimensions

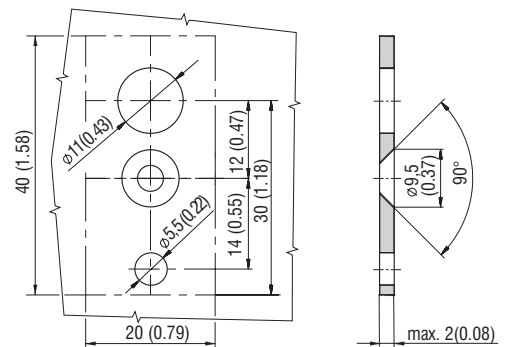

Characteristics measured at $v = 32 \text{ mm}^2/\text{s}$ (156 SUS)

Pressure drop related to flow rate

The characteristics were measured at the hand screw set to 30°.

Seat diameter 2 mm (0.08 in)

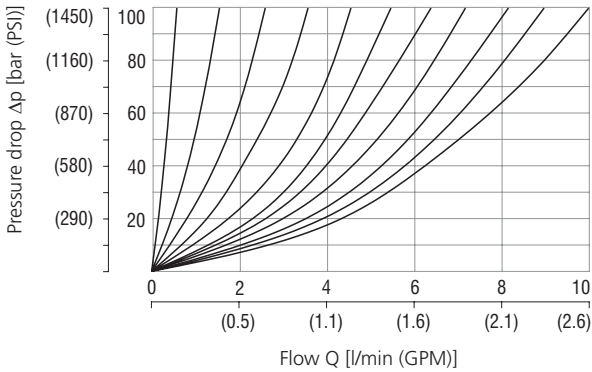

Seat diameter 2.5 mm (0.10 in)

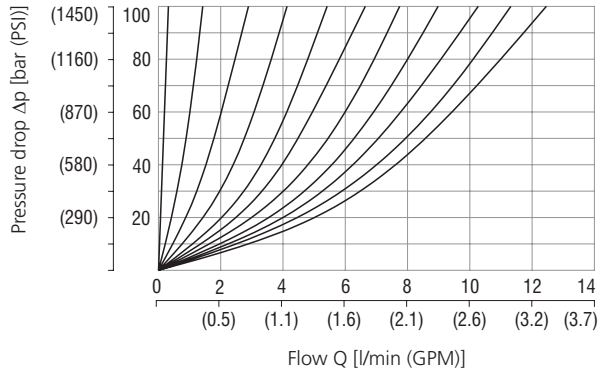

Seat diameter 3 mm (0.12 in)

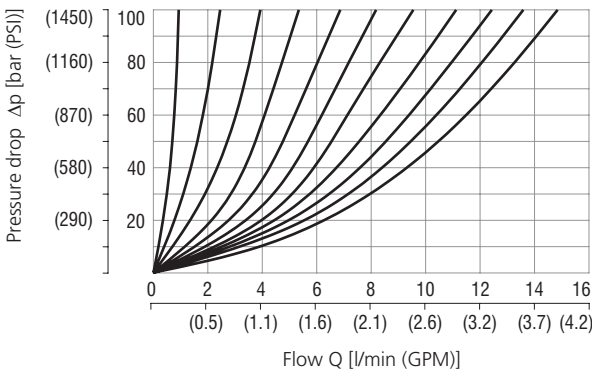

Seat diameter 3.5 mm (0.14 in)

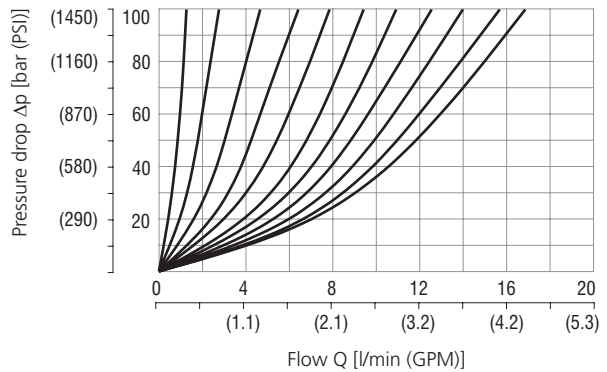

Model VSO1-04/R2-O, direction B - A (free flow)

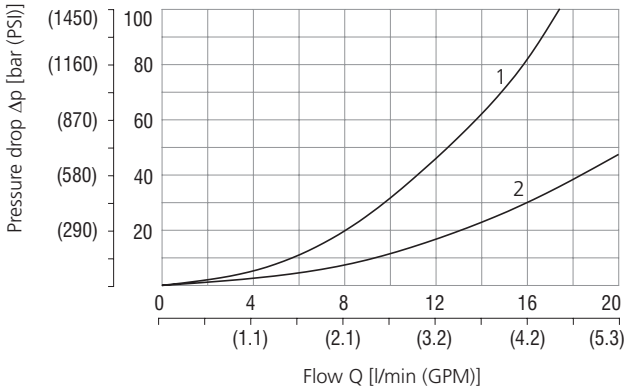

1	Throttle valve closed
2	Throttle valve open

Ordering Code

VSO1-04 / R



Needle - restrictor valve with reverse flow check, fine adjustable

In-line design

Seat diameter
2.0 mm (0.08 in)
2.5 mm (0.10 in)
3.0 mm (0.12 in)
3.5 mm (0.14 in)

Other seat diameters upon request.

2
2,5
3
3,5

No designation

G

No designation
J
O

Seals
standard NBR

Connecting threads
G thread, G1/4

Model
without check valve
with check valve in series
with check valve in parallel