

Magnetic Pickup (MPU)

Magnetic pickups convert mechanical motion into electrical energy without mechanical linkage or external power. These transducers sense any ferromagnetic material having discontinuities, such as gear teeth or slots, and generate an AC Voltage. The frequency of this voltage is equal to the number of discontinuities passing the pickup and is proportional to RPM when the pickup is mounted in proximity to the teeth of a gear on a rotating shaft.

Figure 1 shows the typical construction of a MPU. The pole piece forms a magnetic path from the magnet, creating an external magnetic field in front of the sensor. When this magnetic field is disrupted by a ferromagnetic material an AC voltage is induced in the coil.

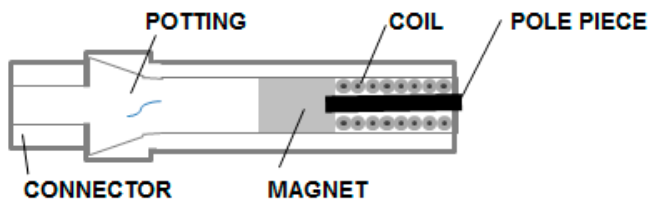

Figure 1

The amplitude of the output voltage depends on the surface speed of the gear, the gap between the pole piece and the gear, the gear tooth size and spacing, and the load impedance. The pickup output voltage is directly proportional to surface speed of the gear. Surface speed is most often expressed in terms of inches per second.

$$\text{Surface Speed (IPS)} = \frac{\text{RPM} \times \text{Gear dia. (inches)} \times 3.1416}{60}$$

Figure 2 shows output voltage as a function of surface speed.

Note: The Altronic intrinsically-safe MPU has internal voltage-limiting zener diodes. The output will never exceed 18V (p-p) regardless of speed.

The AC output voltage is inversely proportional to the clearance between the pole piece and the gear. In many applications a 0.010 to 0.020 inch gap is adequate; however, if slow surface speed or maximum output is required, the gap should be as small as practical (0.005 inches or less).



Figure 2

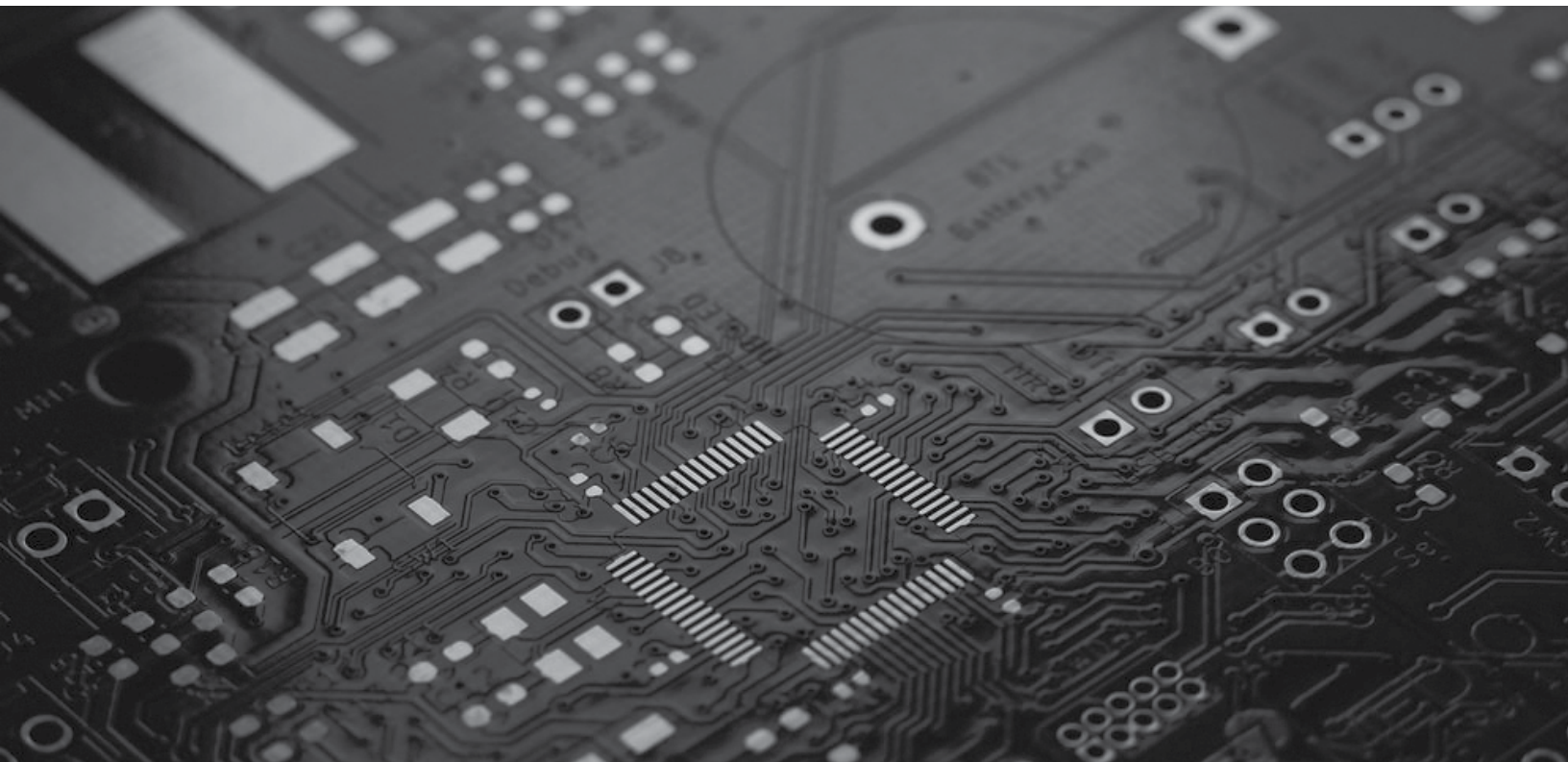

Figure 3 gives the optimum dimensions for a gear to be used with a magnetic pickup. If maximum power is required, the gear should be as close as possible to these dimensions. In many applications small tooth gears are adequate. At high speeds even a 90-pitch gear may be satisfactory. Pitch is the number of teeth per inch diameter.

$$\text{Pitch} = \frac{\text{Number of teeth} + 2}{\text{Diameter of gear (inches)}}$$

or

$$\text{Dia.} = \frac{\text{Number of teeth} + 2}{\text{Pitch}}$$

- A. Equal to or greater than D
- B. Equal to or greater than C
- C. Equal to, or greater than, three times D
- E. As close as possible; typically .005" or less
- F. Equal to or greater than D

Note: Whenever possible a gear of 16 pitch or coarser should be used

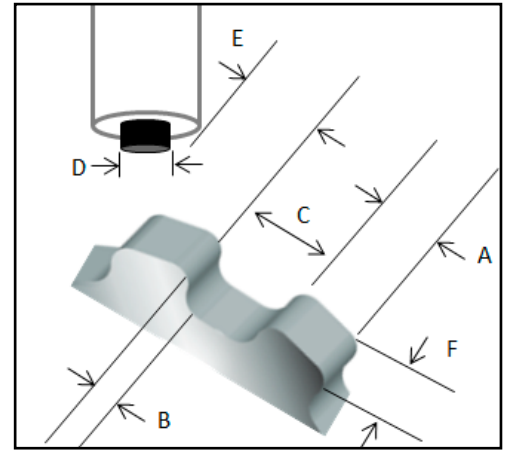

Figure 3

SPECIFICATIONS

Nominal Resistance 1500 OHMS
 Nominal Inductance 500 mH
 Output Voltage 9V o-p MAX (18V p-p MAX.)
 Temperature Operating -65°F to 225°F
 Ambient -100°F to 225°F

TO ORDER

Thickness	Length	Altronic P/N
1.75" / 44.5mm	3.30" / 83.3mm	691118-1
2.5" / 63.5mm	4.05" / 102.8mm	691118-2
3.0" / 76.2mm	4.55" / 115.6mm	691118-3
4.5" / 114.3mm	6.05" / 153.7mm	691118-4
6.0" / 152.4mm	7.55" / 191.8mm	691118-6

DIMENSIONS

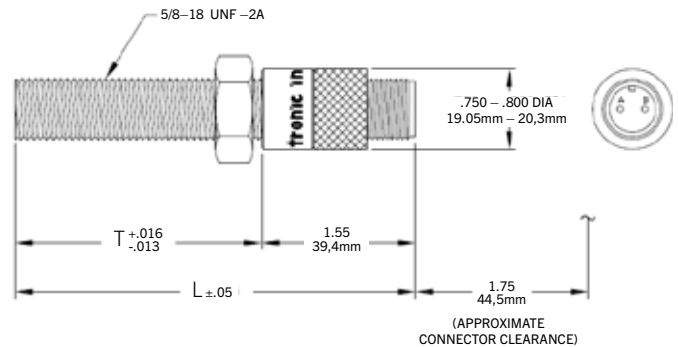

Cable Assembly, Magnetic Pickup

- 693104-1 Pickup Cable, unshielded, 180° connector, 10 ft. cable
- 693104-2 Pickup Cable, unshielded, 180° connector, 20 ft. cable
- 693104-3 Pickup Cable, unshielded, 180° connector, 30 ft. cable
- 693104-4 Pickup Cable, unshielded, 180° connector, 40 ft. cable
- 693104-5 Pickup Cable, unshielded, 180° connector, 50 ft. cable
- 593048-L Pickup Cable, shielded, 180° connector, L" conduit, 50 ft. cable
L = 12", 18", 24", 36", 48", 72", 96", 120"
- 593054-L Pickup Cable, shielded, 90° connector, L" conduit, 50 ft. cable
L = 12", 18", 24", 36", 48", 72", 96", 120"
- 593048A-L Pickup Cable, shielded, 180° connector, L" conduit, 100 ft. cable
L = 24", 48", 72", 96"
- 593054A-L Pickup Cable, shielded, 90° connector, L" conduit, 100 ft. cable
L = 24", 48", 72", 96"

NOTE: Above shielded cables are CSA certified for Class I, Division 2, Group D hazardous locations when used with other applicable CSA-certified Altronic components. The standard cables have 50' of PU cable, and the "A" suffix variation has 100' of PU cable.

