

# *EP5 Electropneumatic positioner*

Product  
Information

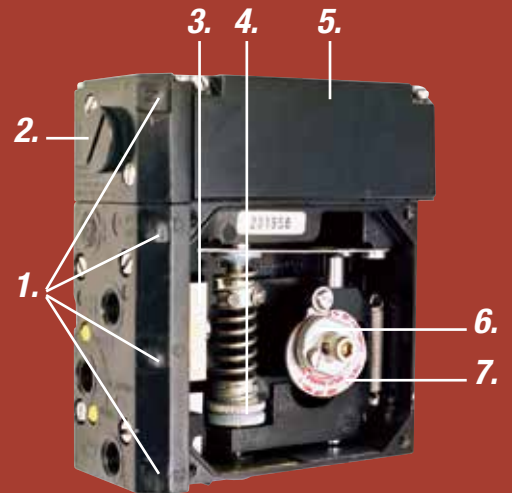

1. Gauge ports
2. Filter plug
3. Spool valve (High performance or Normal Gain)
4. Simple calibration of span & zero
5. I/P converter
6. Simple cam locking
7. Stainless cam



## EP5 Electropneumatic Positioner

### EP5

- Modular, sturdy, simple, reliable design.
- Tapped exhaust port.
- Easy to add on Feedback Unit F5.
- Simple calibration, external zero adjustment.
- High gain pilot valve.
- Built in gauge ports.
- Bright visible indicator, flat or Dome style.
- Stainless steel cam.

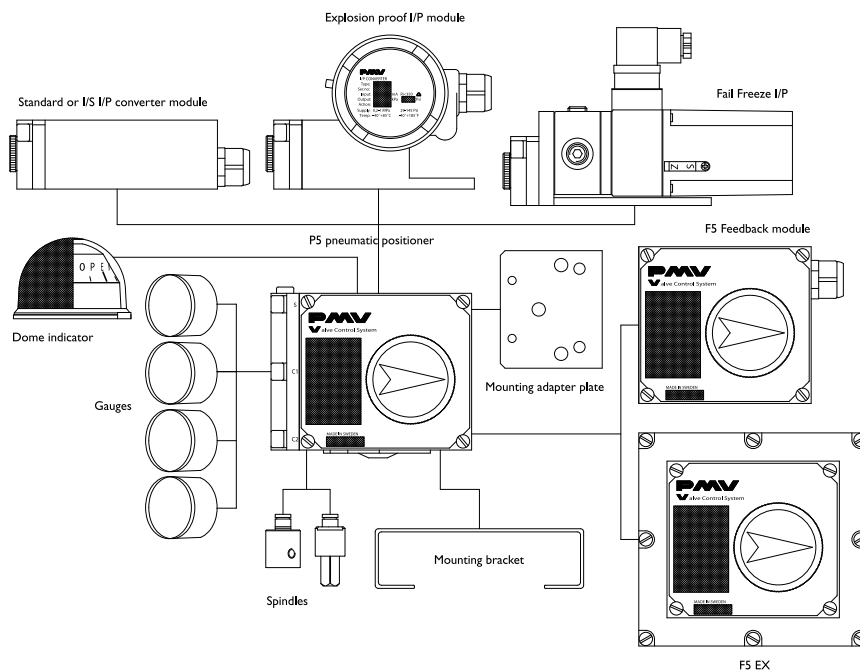



## Technical data

Deadband	≤ 0.15%
Input signal	4–20 mA
Linearity	≤ 1%*
Hysteresis	≤ 0.75%*
Repeatability	≤ 0.5%*
Air supply	Max. 1 MPa/150 Psi, Oil, water and dustfree Min. 0.14 MPa/21 Psi
Connector threads	1/4" NPT or G (BSP)
Gauge threads	1/8" NPT or G (BSP)
Conduit entry	1/2" NPT or M20 x 1,5
Terminals	2.5 mm <sup>2</sup> (AWG 14) Screw terminals

### Gain factor at: 600 KPa/87 Psi

### High Performance Version

### Normal Gain Version

Min: 1000 KPa/KPa

Min: 450 KPa/KPa

Min: 66%/ % ISA S75.13-1989

Min: 30%/ %

### Max. air consumption at supply pressure:

0.2 MPa/29 Psi	6.1 nl/min (0.22 SCFM)	2.7 nl/min (0.1 SCFM)
0.4 MPa/58 Psi	13.6 nl/min (0.48 SCFM)	6.1 nl/min (0.21 SCFM)
0.6 MPa/87 Psi	22 nl/min (0.78 SCFM)	9.9 nl/min (0.35 SCFM)
0.8 MPa/116 Psi	30.5 nl/min (1.08 SCFM)	13.7 nl/min (0.48 SCFM)
1 MPa/145 Psi	39 nl/min (1.38 SCFM)	17.5 nl/min (0.62 SCFM)

### Min. air delivery at supply pressure:

0.2 MPa/29 Psi	200 nl/min (6.9 SCFM)	156 nl/min (5.5 SCFM)
0.4 MPa/58 Psi	370 nl/min (12.8 SCFM)	288 nl/min (10.1 SCFM)
0.6 MPa/87 Psi	540 nl/min (18.8 SCFM)	421 nl/min (14.8 SCFM)
0.8 MPa/116 Psi	710 nl/min (24.7 SCFM)	553 nl/min (19.4 SCFM)
1 MPa/145 Psi	880 nl/min (30.6 SCFM)	686 nl/min (24 SCFM)

Input impedance	170–260 Ohms at 20°C (71°F)
RFI influence	Not measurable
Capacitance	Negligible
Position sensivity	None
Supply pressure effect	0.5%/0.1 MPa (15 Psi)
Temperature range	–20°C to +85°C/(–4°F to +185°F)
Low temp option	–40°C to +85°C/(–40°F to +185°F)
Weight	1.5 kg/3.4 lbs
Housing	Die cast aluminum
Surface treatment	ED Epoxy paint, black
Fasteners	A2/A4 Stainless
Ingress protection	IP 66/NEMA 4

### Approvals

ATEX	Intrinsically safe	EEX ia IIC T4–T6 Ⓢ II 1 G	Non-electrical device P5 Ⓢ II 1 G
	Flameproof**	EEX d IIB+H2 T4–T6 Ⓢ II 2 G	
FM	Intrinsically safe	Div.1, Class 1 Group ABCD	
	Explosion proof**	Div.1, Class 1 Group BCD	
CSA	Intrinsically safe	Div.1, Class 1 Group ABCD	
	Explosion proof**	Div.1, Class 1,2,3 Group BCDEFG	

\* Percent of full scale

\*\* I/P in round housing



### Modular

- EP5 For all normal applications
- EP5-EX Explosion proof
- EP5-FS Fail freeze
- EP5-IS Intrinsically safe



### EP5 Series Coding

<b>Model</b>	
EP5XX	EP5 Double acting pneumatic
EP5FS	Fail freeze function
EP5IS	Intrinsically safe, ATEX, FM, CSA
EP5EX	Explosion proof ATEX
<b>Spool valve</b>	
HP	High performance
LB	Normal Gain
<b>Connections</b>	
N	NPT 1/4", El. 1/2" NPT
G	G 1/4" air, M20 x 1,5 electric
M	NPT 1/4" air, M20 x 1,5 electric
<b>Surface treatment</b>	
U	Epoxy coating
M	Tufram
<b>Spindle</b>	
01, 23 etc	01 to 39. See dwg SPNDLS_P5
<b>Cam</b>	
K01, K08 etc	K01 to K34
<b>Front cover</b>	
PV9DA*	90°, Direct, arrow indicator
<b>Input signal</b>	
4	4-20 mA input
<b>Temperature</b>	
N	Nitrile seals -20°C to +85°C
Q	Silicon seals -40°C to +85°C

\*For 30, 45, 60 deg rotation, change PV9 to PV3, PV4 or PV6

**Example**  
EP5XX-HPNU-23K01-PV9DA-4Z

### Cams

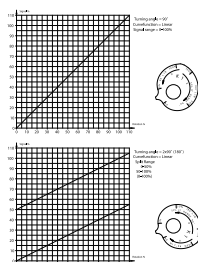

K1

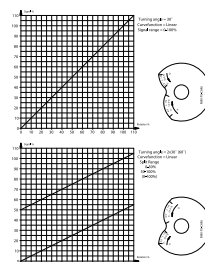

K3

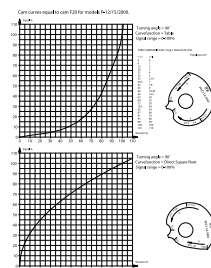

K8

## Spindles

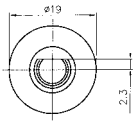

S 39

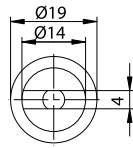
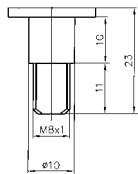

S23

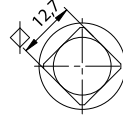
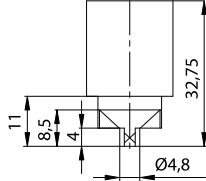

S30

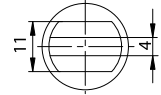
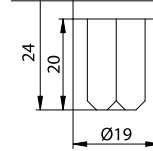

S36

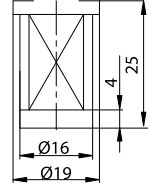

## Dimensions drawings (mm)

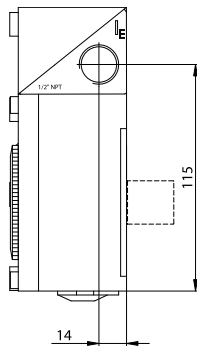

EP5

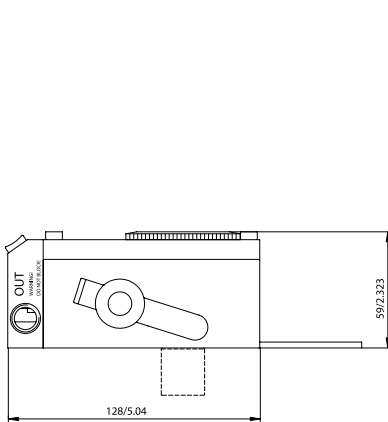
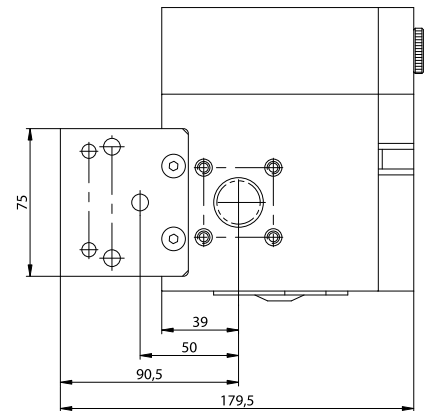
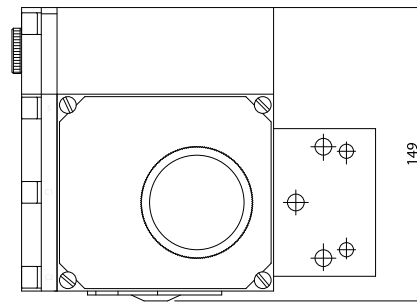

EP5

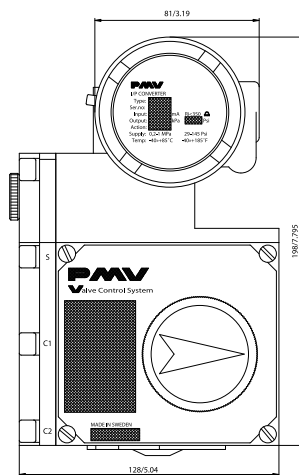

EP5 EX

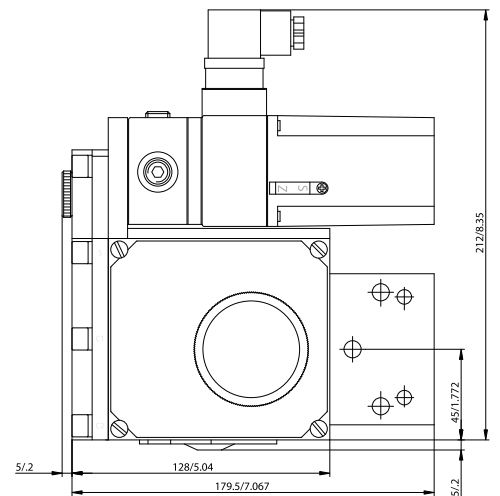

EP5-FS