

# Absolute encoders – multiturn

<b>Standard electronic multiturn, optical</b>	<b>Sendix F5863 / F5883 (shaft / hollow shaft)</b>	<b>SSI / BiSS + incremental</b>
---	--	---------------------------------



The Sendix F58 Multiturn with patented Intelligent Scan Technology™ is a particularly high-resolution optical multiturn encoder without gears and with magnetically insensitive sensor technology.

41 bits total resolution, through hollow shaft up to 15 mm and versions with additional SinCos or RS422 incremental track.



<b>24 bit MT</b> Multiturn resolution	<b>Safety-Lock™</b>	<b>High rotational speed</b>	<b>-40°...+85°C</b> Temperature range	<b>IP</b> High protection level	<b>High shaft load capacity</b>	<b>Shock / vibration resistant</b>	<b>Magnetic field proof sensor technology</b>	<b>Reverse polarity protection</b>	<b>Intelligent Scan Technology™</b>	<b>Surface protection salt spray-tested optional</b>
--	---------------------	------------------------------	--	------------------------------------	---------------------------------	------------------------------------	---	------------------------------------	-------------------------------------	--

## Reliable and insensitive

- Sturdy bearing construction in Safety-Lock™ design for resistance against vibration and installation errors.
- Ideal for use outdoors thanks to IP67 protection and wide temperature range from -40 °C up to +85 °C.
- Patented Intelligent Scan Technology™ with all singleturn and multiturn functions on one single OptoASIC - offering highest reliability.
- High resolution up to 41 bits and magnetically insensitive sensor technology.

## Versatile

- Available with SSI or BiSS interface and combined with SinCos incremental signals.
- The right fixing solution or type of connection available for every application.
- SET button and LED for simple start-up.
- High resolution feedback in real-time via incremental outputs SinCos and RS422.
- Short control cycles, clock frequency with SSI up to 2 MHz / with BiSS up to 10 MHz.

**Order code**      **8.F5863** . XXXX . XXXX

**Shaft version**      Type      a b c d e f g h

If for each parameter of an encoder the **underlined preferred option** is selected, then the delivery time will be 10 working days for a maximum of 10 pieces. Qts. up to 50 pcs. of these types generally have a delivery time of 15 working days.



<p><b>a Flange</b></p> <p><u>1</u> = clamping flange, IP65 ø 58 mm [2.28"] 3 = clamping flange, IP67 ø 58 mm [2.28"] <u>2</u> = synchro flange, IP65 ø 58 mm [2.28"] 4 = synchro flange, IP67 ø 58 mm [2.28"]</p> <p><b>b Shaft (ø x L), with flat</b></p> <p><u>1</u> = 6 x 10 mm [0.24 x 0.39"]<sup>1)</sup> <u>2</u> = 10 x 20 mm [0.39 x 0.79"]<sup>2)</sup> 3 = 1/4" x 7/8" 4 = 3/8" x 7/8"</p>	<p><b>c Interface / supply voltage</b></p> <p>1 = SSI, BiSS / 5 V DC <u>2</u> = <b>SSI, BiSS / 10 ... 30 V DC</b> 3 = SSI, BiSS + 2048 ppr. SinCos / 5 V DC 4 = SSI, BiSS + 2048 ppr. SinCos / 10 ... 30 V DC 5 = SSI, BiSS / 5 V DC, with sensor output 6 = SSI, BiSS + 2048 ppr. SinCos / 5 V DC, with sensor output 7 = SSI, BiSS + 2048 ppr. RS422 (TTL-comp.) / 5 V DC 8 = SSI, BiSS + 2048 ppr. RS422 (TTL-comp.) / 10 ... 30 V DC</p> <p><b>d Type of connection</b></p> <p>1 = axial cable, 1 m [3.28'] PVC A = axial cable, special length PVC *) <u>2</u> = <b>radial cable, 1 m [3.28'] PVC</b> B = radial cable, special length PVC *) 3 = axial M23 connector, 12-pin <u>4</u> = <b>radial M23 connector, 12-pin</b> 5 = axial M12 connector, 8-pin<sup>3)</sup> 6 = radial M12 connector, 8-pin<sup>3)</sup></p> <p>*) Available special lengths (connection types A, B): 2, 3, 5, 8, 10, 15 m [5.56, 9.84, 16.40, 26.25, 32.80, 49.21'] order code expansion .XXXX = length in dm ex.: 8.F5863.122A.G323.0030 (for cable length 3 m)</p>	<p><b>e Code</b></p> <p>B = SSI, binary C = BiSS, binary <u>G</u> = <b>SSI, gray</b></p> <p><b>f Resolution (singleturn)<sup>4)</sup></b></p> <p>B = 9 bit ST A = 10 bit ST 1 = 11 bit ST 2 = 12 bit ST <u>3</u> = <b>13 bit ST</b> 4 = 14 bit ST 7 = 17 bit ST</p> <p><i>Optional on request</i></p> <ul style="list-style-type: none"> <li>- Ex 2/22<sup>5)</sup></li> <li>- surface protection salt spray tested</li> <li>- other resolutions</li> </ul>	<p><b>g Resolution (multiturn)<sup>4)</sup></b></p> <p><u>2</u> = <b>12 bit MT</b> 6 = 16 bit MT 4 = 24 bit MT</p> <p><b>h Options (service)</b></p> <p>1 = no option 2 = status LED <u>3</u> = <b>SET button and status LED</b></p>
--	---	---	--

1) Preferred type only in conjunction with flange type 2.  
2) Preferred type only in conjunction with flange type 1.  
3) Can be combined only with interface 1 and 2.

4) Resolution, preset value and counting direction factory-programmable.  
5) For the cable connection type, cable material PUR.

# Absolute encoders – multiturn

<b>Standard electronic multiturn, optical</b>	<b>Sendix F5863 / F5883 (shaft / hollow shaft)</b>	<b>SSI / BiSS + incremental</b>
---	--	---------------------------------

<b>Order code</b>	<b>Hollow shaft</b>	<b>8.F5883</b>	<b>XXXXX</b>	<b>XXXXX</b>	If for each parameter of an encoder the <u>underlined preferred option</u> is selected, then the delivery time will be 10 working days for a maximum of 10 pieces. Qts. up to 50 pcs. of these types generally have a delivery time of 15 working days.	
	Type		a b c d	e f g h		
<b>a</b> Flange	1 = with spring element, long, IP65 2 = with spring element, long, IP67 3 = with stator coupling, IP65, ø 65 mm [2.56"] 4 = with stator coupling, IP67, ø 65 mm [2.56"] <u>5 = with stator coupling, IP65, ø 63 mm [2.48"]</u> 6 = with stator coupling, IP67, ø 63 mm [2.48"]	<b>c</b> Interface / supply voltage 1 = SSI, BiSS / 5 V DC <u>2 = SSI, BiSS / 10 ... 30 V DC</u> 3 = SSI, BiSS + 2048 ppr. SinCos / 5 V DC 4 = SSI, BiSS + 2048 ppr. SinCos / 10 ... 30 V DC 5 = SSI, BiSS / 5 V DC, with sensor output 6 = SSI, BiSS + 2048 ppr. SinCos / 5 V DC, with sensor output 7 = SSI, BiSS + 2048 ppr. RS422 (TTL-comp.) / 5 V DC 8 = SSI, BiSS + 2048 ppr. RS422 (TTL-comp.) / 10 ... 30 V DC	<b>e</b> Code B = SSI, binary C = BiSS, binary <u>G = SSI, gray</u>	<b>g</b> Resolution (multiturn) <sup>1)</sup> <u>2 = 12 bit MT</u> 6 = 16 bit MT 4 = 24 bit MT	<b>i</b> Resolution (singleturn) <sup>1)</sup> B = 9 bit ST A = 10 bit ST 1 = 11 bit ST 2 = 12 bit ST <u>3 = 13 bit ST</u> 4 = 14 bit ST 7 = 17 bit ST	<b>h</b> Options (service) 1 = no option 2 = status LED <u>3 = SET button and status LED</u>
<b>b</b> Through hollow shaft 3 = ø 10 mm [0.39"] <u>4 = ø 12 mm [0.47"]</u> 5 = ø 14 mm [0.55"] 6 = ø 15 mm [0.59"] 8 = ø 3/8" 9 = ø 1/2"	<b>d</b> Type of connection 2 = radial cable, 1 m [3.28'] PVC B = radial cable, special length PVC *) <u>E = tangential cable, 1 m [3.28'] PVC</u> F = tangential cable, special length PVC *) <u>4 = radial M23 connector, 12-pin</u> 6 = radial M12 connector, 8-pin <sup>2)</sup>	*) Available special lengths (connection types B, F): 2, 3, 5, 8, 10, 15 m [5.56, 9.84, 16.40, 26.25, 32.80, 49.21'] order code expansion .XXXX = length in dm ex.: 8.F5883.542B.G323.0030 (for cable length 3 m)				
					Optional on request - Ex 2/22 (not for type of connection E, F) <sup>3)</sup> - surface protection salt spray tested - other resolutions	

Mounting accessory for shaft encoders		Order no.
<b>Coupling</b>	bellows coupling ø 19 mm [0.75"] for shaft 6 mm [0.24"]	<b>8.0000.1102.0606</b>
	bellows coupling ø 19 mm [0.75"] for shaft 10 mm [0.39"]	<b>8.0000.1102.1010</b>

Mounting accessory for hollow shaft encoders		Dimensions in mm [inch]	Order no.
<b>Torque pin, ø 4 mm</b> for flange with spring element (flange type 1)	with fixing thread		<b>8.0010.4700.0000</b>

Cables and connectors		Order no.
<b>Preassembled cables</b>	M12 female connector with coupling nut, 8-pin, A coded, straight single-ended 2 m [6.56'] PVC cable	<b>05.00.6041.8211.002M</b>
	M23 female connector with coupling nut, 12-pin, cw single-ended 2 m [6.56'] PVC cable	<b>8.0000.6901.0002.0031</b>
<b>Connectors</b>	M12 female connector with coupling nut, 8-pin, A coded, straight (metal)	<b>05.CMB 8181-0</b>
	M23 female connector with coupling nut, 12-pin, cw	<b>8.0000.5012.0000</b>

Further Kübler accessories can be found at: [kuebler.com/accessories](http://kuebler.com/accessories)  
 Further Kübler cables and connectors can be found at: [kuebler.com/connection-technology](http://kuebler.com/connection-technology)

1) Resolution, preset value and counting direction factory-programmable.  
 2) Can be combined only with Interface 1 and 2.  
 3) For the cable connection type, cable material PUR.

# Absolute encoders – multiturn

<b>Standard electronic multiturn, optical</b>	<b>Sendix F5863 / F5883 (shaft / hollow shaft)</b>	<b>SSI / BiSS + incremental</b>
---	--	---------------------------------

## Technical data

Mechanical characteristics		
<b>Maximum speed shaft version</b>		
IP65 up to 70 °C [158 °F]	12000 min <sup>-1</sup> , 10000 min <sup>-1</sup> (continuous)	
IP65 up to T <sub>max</sub>	8000 min <sup>-1</sup> , 5000 min <sup>-1</sup> (continuous)	
IP67 up to 70 °C [158 °F]	11000 min <sup>-1</sup> , 9000 min <sup>-1</sup> (continuous)	
IP67 up to T <sub>max</sub>	8000 min <sup>-1</sup> , 5000 min <sup>-1</sup> (continuous)	
<b>Maximum speed hollow shaft version</b>		
IP65 up to 70 °C [158 °F]	9000 min <sup>-1</sup> , 6000 min <sup>-1</sup> (continuous)	
IP65 up to T <sub>max</sub>	6000 min <sup>-1</sup> , 3000 min <sup>-1</sup> (continuous)	
IP67 up to 70 °C [158 °F]	8000 min <sup>-1</sup> , 4000 min <sup>-1</sup> (continuous)	
IP67 up to T <sub>max</sub>	4000 min <sup>-1</sup> , 2000 min <sup>-1</sup> (continuous)	
<b>Starting torque at 20 °C [68 °F]</b>	IP65	< 0.01 Nm
	IP67	< 0.05 Nm
<b>Mass moment of inertia</b>		
	shaft version	3.0 x 10 <sup>-6</sup> kgm <sup>2</sup>
	hollow shaft version	6.0 x 10 <sup>-6</sup> kgm <sup>2</sup>
<b>Load capacity of shaft</b>		
	radial	80 N
	axial	40 N
<b>Weight</b>		
		approx. 0.45 kg [15.87 oz]
<b>Protection acc. to EN 60529</b>		
	housing side	IP67
	shaft side	IP65, opt. IP67
<b>Working temperature range</b>		
		-40 °C ... +85 °C [-40 °F ... +185 °F] <sup>1)</sup>
<b>Material</b>		
	shaft/hollow shaft	stainless steel
	flange	aluminum
	housing	zinc die-cast
	cable	PVC (PUR for Ex 2/22)
<b>Shock resistance acc. to EN 60068-2-27</b>		
		2500 m/s <sup>2</sup> , 6 ms
<b>Vibration resistance acc. to EN 60068-2-6</b>		
		100 m/s <sup>2</sup> , 55 ... 2000 Hz

Electrical characteristics		
<b>Supply voltage</b>		5 V DC (+5%) or 10 ... 30 V DC
<b>Current consumption (no load)</b>	5 V DC	max. 60 mA
	10 ... 30 V DC	max. 30 mA
<b>Reverse polarity protection of the supply voltage</b>		yes (at 10 ... 30 V DC)
<b>Short circuit proof outputs</b>		yes <sup>2)</sup>

SSI interface		
<b>Output driver</b>		RS485 transceiver type
<b>Permissible load / channel</b>		max. +/- 30 mA
<b>Signal level</b>	HIGH	typ 3.8 V
	LOW at I <sub>Load</sub> = 20 mA	typ 1.3 V
<b>Resolution singleturn</b>		10 ... 17 bit
<b>Number of revolutions (multiturn)</b>		max. 24 bit
<b>Code</b>		binary or gray
<b>SSI clock rate</b>		50 kHz ... 2 MHz
<b>Data refresh rate</b>	ST resolution ≤ 14 bit	≤ 1 μs
	ST resolution ≥ 15 bit	4 μs
<b>Monoflop time</b>		≤ 15 μs

**Note:** If the clock starts cycling within the monoflop time, a second data transfer starts with the same data. If the clock starts cycling after the monoflop time, the data transfer starts with the new values. The update rate is dependent on the clock speed, data length and monoflop-time.

BiSS interface		
<b>Output driver</b>		RS485 transceiver type
<b>Permissible load / channel</b>		max. +/- 30 mA
<b>Signal level</b>	HIGH	typ 3.8 V
	LOW at I <sub>Load</sub> = 20 mA	typ 1.3 V
<b>Resolution singleturn</b>		10 ... 17 bit
<b>Number of revolutions (multiturn)</b>		max. 24 bit
<b>Code</b>		binary
<b>BiSS clock rate</b>		50 kHz ... 10 MHz
<b>Max. update rate</b>		< 10 μs, depends on the clock rate and the data length
<b>Data refresh rate</b>	ST resolution ≤ 14 bit	≤ 1 μs
	ST resolution 17 bit	2.4 μs
<b>Note:</b>	<ul style="list-style-type: none"> <li>- bidirectional, factory programmable parameters are: resolution, code, direction, alarms and warnings</li> <li>- CRC data verification</li> </ul>	

Status output and LED		
<b>Output driver</b>		open collector, internal pull up resistor 22 kOhm
<b>Permissible load</b>		max. 20 mA
<b>Signal level</b>		HIGH: +V / LOW: < 1 V
<b>Active</b>		LOW
<p>The optional LED (red) and the status output serve to display various alarm or error messages. In normal operation the LED is OFF and the status output is HIGH (open collector with int. pull up 22 kOhm).</p> <p>An active status output (LOW) displays:</p> <ul style="list-style-type: none"> <li>- sensor error, singleturn or multiturn (soiling, glass breakage etc.)</li> <li>- LED fault (failure or ageing)</li> <li>- over- or under-temperature</li> </ul>		
<p>In the SSI mode, the fault indication can only be reset by switching off the power-supply to the device.</p>		

Incremental outputs (A/B)		
	SinCos	RS422 TTL compatible
<b>Max. frequency -3dB</b>	400 kHz	400 kHz
<b>Signal level</b>	1 V <sub>pp</sub> (±20 %)	HIGH: min. 2.5 V LOW: max. 0.5 V
<b>Short circuit proof</b>	yes <sup>2)</sup>	yes <sup>2)</sup>
<b>Pulse rate</b>	2048 ppr	2048 ppr

1) Cable version: -30 °C ... +75 °C [-22 °F ... +167 °F].

2) Short circuit to 0 V or to output; if supply voltage correctly applied.

# Absolute encoders – multiturn

<b>Standard electronic multiturn, optical</b>	<b>Sendix F5863 / F5883 (shaft / hollow shaft)</b>	<b>SSI / BiSS + incremental</b>
---	--	---------------------------------

SET input		
<b>Input</b>	active HIGH	
<b>Input type</b>	comparator	
<b>Signal level</b> (+V = supply voltage)	HIGH	min. 60 % of +V, max: +V
	LOW	max. 30 % of +V
<b>Input current</b>	< 0.5 mA	
<b>Min. pulse duration (SET)</b>	10 ms	
<b>Input delay</b>	1 ms	
<b>New position data readable after</b>	1 ms	
<b>Internal processing time</b>	200 ms	

The encoder can be set to zero at any position by means of a HIGH signal on the SET input or by pressing the optional SET button (with a pencil, ball-point pen or similar). Other preset values can be factory-programmed. The SET input has a signal processing time of approx. 1 ms, after which the new position data can be read via SSI or BiSS. Once the SET function has been triggered, the encoder requires an internal processing time of typ. 200 ms; during this time the supply voltage must not be switched off.

The SET function should be carried out whilst the encoder is at rest.

If this input is not used, it should be connected to 0 V (Encoder ground GND) in order to avoid interferences.

DIR input	
<p>Direction input: A HIGH signal switches the direction of rotation from the default cw to ccw. This inverted function can also be factory-programmed. If DIR is changed when the device is already switched on, then this will be interpreted as an error. The status output will switch to LOW.</p> <p>If this input is not used, it should be connected to 0 V (Encoder ground GND) in order to avoid interferences.</p>	
<b>Response time (DIR input)</b>	1 ms

Power-ON	
<p>After Power-ON the device requires a time of approx. 150 ms before valid data can be read.</p>	
<p>Hot plugging of the encoder should be avoided.</p>	

Approvals		
<b>UL compliant</b> in accordance with	File no. E224618	
<b>CE compliant</b> in accordance with		
	EMC Directive	2014/30/EU
	RoHS Directive	2011/65/EU
	ATEX Directive	2014/34/EU (for Ex 2/22 variants)

# Absolute encoders – multiturn

<b>Standard electronic multiturn, optical</b>	<b>Sendix F5863 / F5883 (shaft / hollow shaft)</b>	<b>SSI / BiSS + incremental</b>
---	--	---------------------------------

## Terminal assignment

Interface	Type of connection	Features	Cable (isolate unused cores individually before initial start-up)
1, 2	1, 2, A, B, E, F	SET, DIR, Status	Signal: 0 V +V C+ C- D+ D- SET DIR ERR\ N/C N/C N/C $\perp$
			Core color: WH BN GN YE GY PK BU RD BK - - - shield
Interface	Type of connection	Features	M23 connector, 12-pin
1, 2	3, 4	SET, DIR, Status	Signal: 0 V +V C+ C- D+ D- SET DIR ERR\ N/C N/C N/C $\perp$
			Pin: 1 2 3 4 5 6 7 8 9 10 11 12 PH
Interface	Type of connection	Features	Cable (isolate unused cores individually before initial start-up)
5	1, 2, A, B, E, F	SET, DIR, Status sensor output	Signal: 0 V +V C+ C- D+ D- SET DIR ERR\ N/C 0Vsens +Vsens $\perp$
			Core color: WH BN GN YE GY PK BU RD BK - GY-PK RD-BU shield
Interface	Type of connection	Features	M23 connector, 12-pin
5	3, 4	SET, DIR, Status sensor output	Signal: 0 V +V C+ C- D+ D- SET DIR ERR\ N/C 0Vsens +Vsens $\perp$
			Pin: 1 2 3 4 5 6 7 8 9 10 11 12 PH
Interface	Type of connection	Features	Cable (isolate unused cores individually before initial start-up)
3, 4, 7, 8	1, 2, A, B, E, F	SET, DIR, SinCos or incr. RS422	Signal: 0 V +V C+ C- D+ D- SET DIR A $\bar{A}$ B $\bar{B}$ $\perp$
			Core color: WH BN GN YE GY PK BU RD BK VT GY-PK RD-BU shield
Interface	Type of connection	Features	M23 connector, 12-pin
3, 4, 7, 8	3, 4	SET, DIR, SinCos or incr. RS422	Signal: 0 V +V C+ C- D+ D- SET DIR A $\bar{A}$ B $\bar{B}$ $\perp$
			Pin: 1 2 3 4 5 6 7 8 9 10 11 12 PH
Interface	Type of connection	Features	Cable (isolate unused cores individually before initial start-up)
6	1, 2, A, B, E, F	SinCos o. incr. RS422 sensor output	Signal: 0 V +V C+ C- D+ D- A $\bar{A}$ B $\bar{B}$ 0Vsens +Vsens $\perp$
			Core color: WH BN GN YE GY PK BU RD BK VT GY-PK RD-BU shield
Interface	Type of connection	Features	M23 connector, 12-pin
6	3, 4	SinCos o. incr. RS422 sensor output	Signal: 0 V +V C+ C- D+ D- A $\bar{A}$ B $\bar{B}$ 0Vsens +Vsens $\perp$
			Pin: 1 2 3 4 5 6 7 8 9 10 11 12 PH
Interface	Type of connection	Features	M12 connector, 8-pin
1, 2	5, 6	SET, DIR	Signal: 0 V +V C+ C- D+ D- SET DIR $\perp$
			Pin: 1 2 3 4 5 6 7 8 PH

- +V: Supply voltage encoder +V DC
- 0 V: Supply voltage encoder ground GND (0 V)
- 0 Vsens / +Vsens: Using the sensor outputs of the encoder, the voltage present can be measured and if necessary increased accordingly.
- C+, C-: Clock signal
- D+, D-: Data signal
- A,  $\bar{A}$ : Incremental output channel A (cosine)
- B,  $\bar{B}$ : Incremental output channel B (sine)
- SET: Set input
- DIR: Direction input
- ERR: Status output
- PH  $\perp$ : Plug connector housing (shield)

### Top view of mating side, male contact base

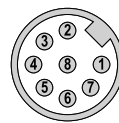

M12 connector, 8-pin

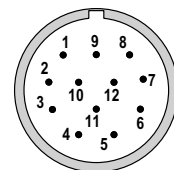

M23 connector, 12-pin

# Absolute encoders – multiturn

**Standard  
electronic multiturn, optical**

**Sendix F5863 / F5883 (shaft / hollow shaft)**

**SSI / BiSS + incremental**

## Dimensions shaft version

Dimensions in mm [inch]

### Clamping flange, ø 58 [2.28]

#### Flange type 1 and 3

(drawing with M23 connector)

- 1 3 x M3, 6 [0.24] deep
- 2 3 x M4, 8 [0.32] deep

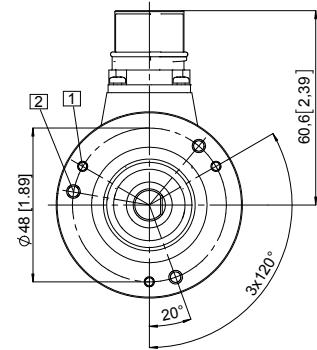
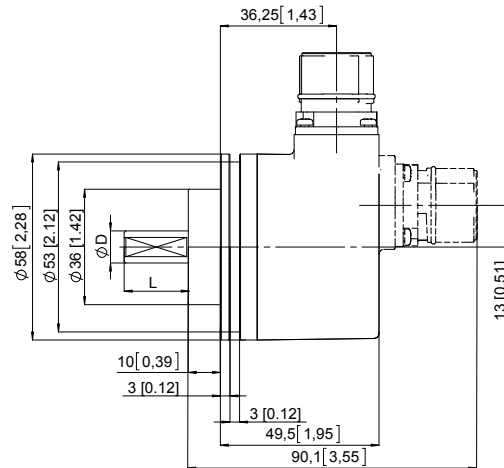

D	Fit	L
6 [0.24]	h7	10 [0.39]
10 [0.39]	f7	20 [0.79]
1/4"	h7	7/8"
3/8"	h7	7/8"

### Synchro flange, ø 58 [2.28]

#### Flange type 2 and 4

(drawing with M12 connector)

- 1 3 x M4, 6 [0.24] deep

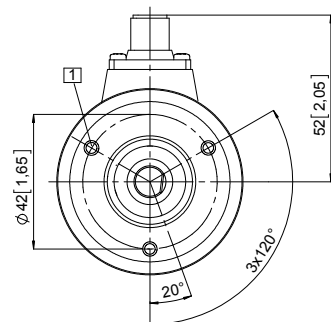
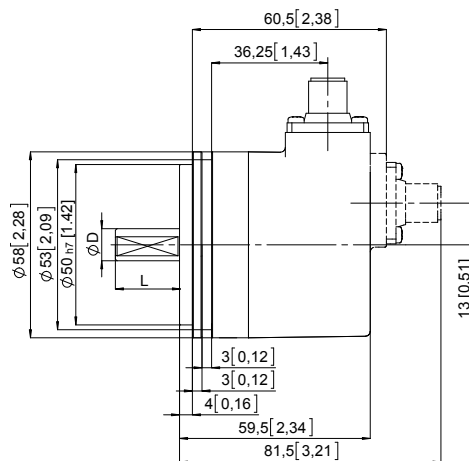

D	Fit	L
6 [0.24]	h7	10 [0.39]
10 [0.39]	f7	20 [0.79]
1/4"	h7	7/8"
3/8"	h7	7/8"

# Absolute encoders – multiturn

<b>Standard electronic multiturn, optical</b>	<b>Sendix F5863 / F5883 (shaft / hollow shaft)</b>	<b>SSI / BiSS + incremental</b>
---	--	---------------------------------

## Dimensions hollow shaft version

Dimensions in mm [inch]

### Flange with spring element, long

#### Flange type 1 and 2

(drawing with M12 connector)

- 1 Slot spring element, recommendation: torque pin DIN 7,  $\phi$  4 [0.16]
- 2 3 x M3, 5.5 [0.22] deep
- 3 Recommended torque for the clamping ring 0.6 Nm

D	Fit
10 [0.39]	H7
12 [0.47]	H7
14 [0.55]	H7
15 [0.59]	H7
3/8"	H7
1/2"	H7

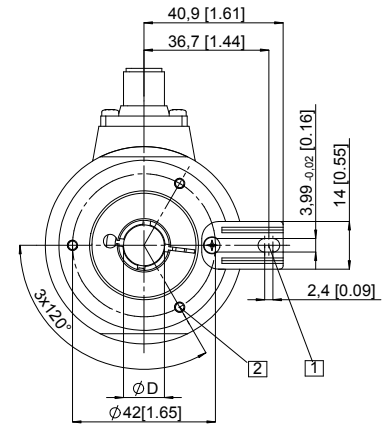
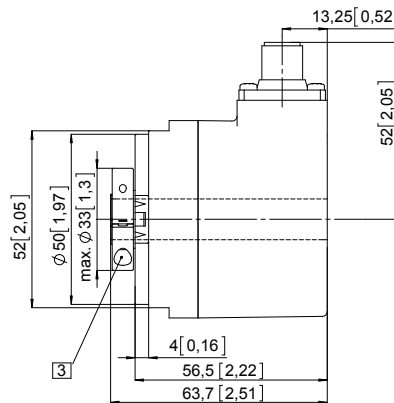

(drawing with tangential cable)

- 1 Slot spring element, recommendation: torque pin DIN 7,  $\phi$  4 [0.16]
- 2 3 x M3, 5.5 [0.22] deep
- 3 Recommended torque for the clamping ring 0.6 Nm

D	Fit
10 [0.39]	H7
12 [0.47]	H7
14 [0.55]	H7
15 [0.59]	H7
3/8"	H7
1/2"	H7

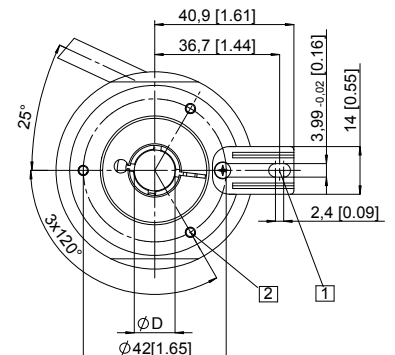
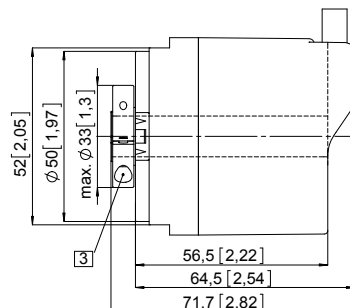

- 4 Status-LED
- 5 SET button

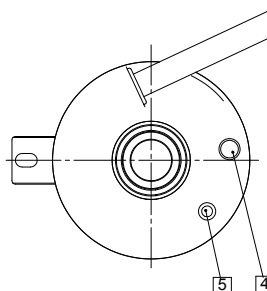

# Absolute encoders – multiturn

**Standard  
electronic multiturn, optical**

**Sendix F5863 / F5883 (shaft / hollow shaft)**

**SSI / BiSS + incremental**

## Dimensions hollow shaft version

Dimensions in mm [inch]

### Flange with stator coupling, $\varnothing$ 63 [2.48]

#### Flange type 5 and 6

Pitch circle diameter for fixing screws  
63 mm [2.48]

(drawing with M23 connector)

- 1 Recommended torque for the clamping ring 0.6 Nm
- 2 Fixing screws (4x) DIN 912 M3 x 8 (washer included in delivery)

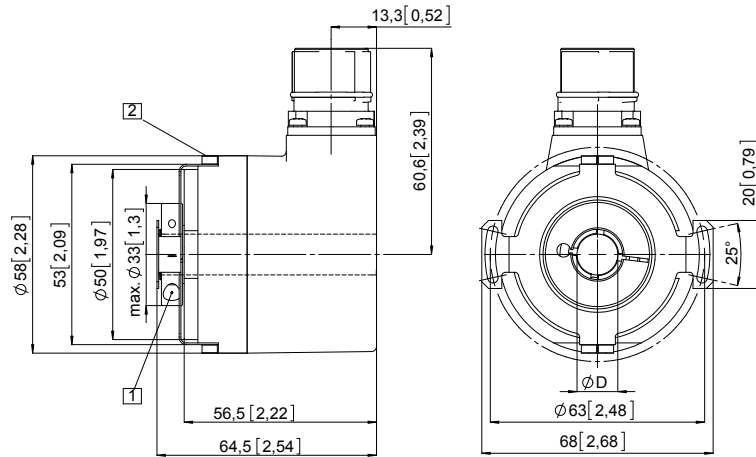

D	Fit
10 [0.39]	H7
12 [0.47]	H7
14 [0.55]	H7
15 [0.59]	H7
3/8"	H7
1/2"	H7

### Flange with stator coupling, $\varnothing$ 65 [2.56]

#### Flange type 3 and 4

Pitch circle diameter for fixing screws  
65 [2.56]

(drawing with cable)

- 1 Recommended torque for the clamping ring 0.6 Nm
- 2 Fixing screws (2x) DIN 912 M3 x 8 (washer included in delivery)

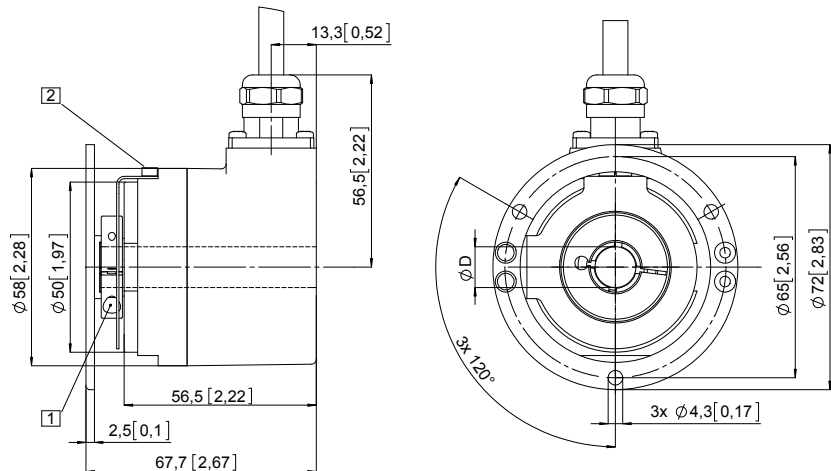

D	Fit
10 [0.39]	H7
12 [0.47]	H7
14 [0.55]	H7
15 [0.59]	H7
3/8"	H7
1/2"	H7