

Incremental encoders

Standard optical	Sendix Base KIS50 / KIH50 (shaft / hollow shaft)	Push-pull / RS422 / Open collector
-------------------------	---	---



The encoders Sendix Base KIS50 / KIH50 offer a protection level up to IP65 and can be used with temperatures from -20 °C up to +70 °C. They are ideal for use in standard applications and in simple machines.

The Sendix Base KIS50 / KIH50 family also features our well proven Safety-Lock™ system, allowing higher tolerance of possible installation errors and increasing the overall performance of this encoder.



Safety-Lock™	High rotational speed	Temperature range	High protection level	High shaft load capacity	Shock / vibration resistant	Magnetic field proof	Short-circuit proof	Reverse polarity protection	Optical sensor

Robust

- Resistant zinc die-cast housing and protection up to IP65.
- Wide temperature range, -20 °C ... +70 °C.
- Elimination of machine downtime thanks to sturdy bearing construction in "Safety-Lock™ Design".

Flexible

- Suitable connection variant for every specific case: cable connection, M12 and M23 connector.
- Various mounting options.
- Up to 5000 pulses per revolution.

Order code	8.KIS50 . XXXXX . XXXX					
Shaft version	Type	a	b	c	d	e
a Flange		b Shaft (ø x L), with flat		c Output circuit / supply voltage		e Pulse rate
8 = clamping flange, IP65 ø 58 mm [2.28"]		1 = ø 6 x 10 mm [0.24 x 0.39"]		4 = RS422 / 5 V DC		100, 120, 200, 250, 256, 300, 360, 500, 512,
B = synchro flange, IP65 ø 58 mm [2.28"]		6 = ø 8 x 15 mm [0.32 x 0.59"]		1 = RS422 / 5 ... 30 V DC		600, 1000, 1024, 1200, 2000, 2048, 2500,
		3 = ø 10 x 20 mm [0.39 x 0.79"]		2 = push-pull / 5 ... 30 V DC		3000, 3600, 4096, 5000
		D = ø 10 x 20 mm [0.39 x 0.79"], on both sides ¹⁾		5 = push-pull / 10 ... 30 V DC		(e.g. 100 pulses => 0100)
		5 = ø 12 x 20 mm [0.47 x 0.79"]		3 = open collector / 5 ... 30 V DC		
		8 = ø 3/8 x 7/8"		d Type of connection		<i>High performance version (optionally available)</i>
				1 = axial cable, 1 m [3.28'] PVC		- Extended temperature range
				2 = radial cable, 1 m [3.28'] PVC		- Higher rotational speed
				P = axial M12 connector, 5-pin		- Higher shock resistance
				R = radial M12 connector, 5-pin		- Higher vibration resistance
				3 = axial M12 connector, 8-pin		Order code 8.KIS50.xxxx.xxxx.9888
				4 = radial M12 connector, 8-pin		
				7 = axial M23 connector, 12-pin		
				8 = radial M23 connector, 12-pin		

1) Suitable for measuring wheel systems MWE52 or MWE62.
Only available with flange option a = 8 and radial type of connection.

Incremental encoders

Standard optical	Sendix Base KIS50 / KIH50 (shaft / hollow shaft)	Push-pull / RS422 / Open collector
-------------------------	---	---

Order code	8.KIH50 . XXXXX . XXXX
Hollow shaft	<div style="display: flex; justify-content: space-between; align-items: center;"> <div style="text-align: center;"> <p>Type</p> <p>a b c d e</p> </div> <div style="text-align: center;"> <p>a b c d e</p> </div> </div>
a Flange	<p>2 = with spring element, long, IP65 4 = with torque stop, long, IP65 D = with stator coupling, IP65, ø 63 mm [2.48"]</p>
b Through hollow shaft	<p>9 = ø 8 mm 4 = ø 3/8" (9,52 mm) 3 = ø 10 mm 5 = ø 12 mm 6 = ø 1/2" (12,75 mm) A = ø 14 mm 8 = ø 15 mm</p>
c Output circuit / supply voltage	<p>4 = RS422 / 5 V DC 1 = RS422 / 5 ... 30 V DC 2 = push-pull / 5 ... 30 V DC 5 = push-pull / 10 ... 30 V DC 3 = open collector / 5 ... 30 V DC</p>
d Type of connection	<p>1 = radial cable, 1 m [3.28'] PVC R = radial M12 connector, 5-pin 2 = radial M12 connector, 8-pin 4 = radial M23 connector, 12-pin E = tangential cable, 1 m [3.28'] PVC</p>
e Pulse rate	<p>100, 120, 200, 250, 256, 300, 360, 500, 512, 600, 1000, 1024, 1200, 2000, 2048, 2500, 3000, 3600, 4096, 5000 (e.g. 100 pulses => 0100)</p> <p><i>High performance version (optionally available)</i></p> <ul style="list-style-type: none"> - Extended temperature range - Higher rotational speed - Higher shock resistance - Higher vibration resistance <p>Order code 8.KIH50.xxxx.xxxx.9888</p>

Mounting accessory for shaft encoders	Order no.
Coupling	
bellows coupling ø 19 mm [0.75"] for shaft 6 mm [0.24"]	8.0000.1102.0606
bellows coupling ø 19 mm [0.75"] for shaft 10 mm [0.39"]	8.0000.1102.1010

Mounting accessory for hollow shaft encoders	Order no.
Torque pin, ø 4 mm	
with fixing thread	8.0010.4700.0000
for flange with spring element (flange type 1 + 2)	

Cables and connectors	Order no.
Preassembled cables	
M12 female connector with coupling nut, 8-pin, A coded, straight single ended 2 m [6.56'] PVC cable	05.00.6041.8211.002M
M23 female connector with coupling nut, 12-pin, cw single ended 2 m [6.56'] PVC cable	8.0000.6901.0002
Connectors	
M12 female connector with coupling nut, 8-pin, A coded, straight (metal)	05.CMB 8181-0
M23 female connector with coupling nut, 12-pin, cw	8.0000.5012.0000

Further Kübler accessories can be found at: kuebler.com/accessories
 Further Kübler cables and connectors can be found at: kuebler.com/connection-technology

Incremental encoders

Standard optical	Sendix Base KIS50 / KIH50 (shaft / hollow shaft)	Push-pull / RS422 / Open collector
-------------------------	---	---

Technical data

Mechanical characteristics	
Maximum speed	6000 min ⁻¹ for option 9888 8000 min ⁻¹ 3000 min ⁻¹ (continuous)
Mass moment of inertia	shaft version approx. 1.8 x 10 ⁻⁶ kgm ² hollow shaft version approx. 6 x 10 ⁻⁶ kgm ²
Starting torque at 20 °C [68 °F]	< 0.01 Nm
Shaft load capacity	radial 80 N axial 40 N
Weight	approx. 0.4 kg [14.11 oz]
Protection acc. to EN 60529	IP65
Working temperature range	-20 °C ... +70 °C [-4 °F ... +158 °F] for option 9888 -40 °C ... +80 °C [-40 °F ... +176 °F]
Material	shaft stainless steel
Shock resistance acc. to EN 60068-2-27	1000 m/s ² , 6 ms for option 9888 2000 m/s ² , 6 ms
Vibration resistance acc. to EN 60068-2-6	100 m/s ² , 10 ... 2000 Hz for option 9888 200 m/s ² , 10 ... 2000 Hz

Approvals	
CE compliant in accordance with	
EMC Directive	2014/30/EU
RoHS Directive	2011/65/EU

Electrical characteristics					
Output circuit	RS422 (TTL compatible)	RS422 (TTL compatible)	Push-pull	Push-pull (HTL/TTL universal, 7272 compatible)	Open collector (7273)
	Order code 1	4	5	2	3
Supply voltage	5 ... 30 V DC	5 V DC (±5 %)	10 ... 30 V DC	5 ... 30 V DC	5 ... 30 V DC
Power consumption (no load)	typ. 40 mA max. 90 mA	typ. 40 mA max. 90 mA	typ. 50 mA max. 100 mA	typ. 50 mA max. 100 mA	100 mA
Permissible load / channel	max. +/- 20 mA	max. +/- 20 mA	max. +/- 20 mA	max. +/- 20 mA	20 mA sink at 30 V DC
Pulse frequency	max. 300 kHz	max. 300 kHz	max. 300 kHz	max. 300 kHz ¹⁾	max. 300 kHz
Signal level	HIGH min. 2.5 V LOW max. 0.5 V	min. 2.5 V max. 0.5 V	min +V - 1.0 V max. 0.5 V	min. +V - 2.0 V max. 0.5 V	
Rising edge time t_r	max. 200 ns	max. 200 ns	max. 1 µs	max. 1 µs	
Falling edge time t_f	max. 200 ns	max. 200 ns	max. 1 µs	max. 1 µs	
Short circuit proof outputs ²⁾	yes ³⁾	yes ³⁾	yes	yes	yes
Reverse polarity protection of the supply voltage	yes	no	yes	no	no

1) Max. recommended cable length 30 m [98.43'].
 2) If supply voltage correctly applied.
 3) Only one channel allowed to be shorted-out:
 at +V= 5 V DC, short-circuit to channel, 0 V, or +V is permitted.
 at +V= 5 ... 30 V DC, short-circuit to channel or 0 V is permitted.

Incremental encoders

Standard optical	Sendix Base KIS50 / KIH50 (shaft / hollow shaft)	Push-pull / RS422 / Open collector
-------------------------	---	---

Terminal assignment

Output circuit	Type of connection	Cable (isolate unused cores individually before initial start-up)												
1, 2, 3, 4, 5	KIS50: 1, 2	Signal:	0 V	+V	0 Vsens	+Vsens	A	\bar{A}	B	\bar{B}	0	$\bar{0}$	\perp	
	KIH50: 1, E	Core color:	WH	BN	GY PK	RD BU	GN	YE	GY	PK	BU	RD	shield	
Output circuit	Type of connection	M12 connector, 5-pin												
1, 2, 3, 4, 5	KIS50: P, R	Signal:	0 V	+V	A	B	0	\perp						
	KIH50: R	Pin:	1	2	3	4	5	PH ¹⁾						
Output circuit	Type of connection	M12 connector, 8-pin												
1, 2, 3, 4, 5	KIS50: 3, 4	Signal:	0 V	+V	0 Vsens	+Vsens	A	\bar{A}	B	\bar{B}	0	$\bar{0}$	\perp	
	KIH50: 2	Pin:	1	2			3	4	5	6	7	8	PH ¹⁾	
Output circuit	Type of connection	M23 connector, 12-pin												
1, 2, 3, 4, 5	KIS50: 7, 8	Signal:	0 V	+V	0 Vsens	+Vsens	A	\bar{A}	B	\bar{B}	0	$\bar{0}$	\perp	
	KIH50: 4	Pin:	10	12	11	2	5	6	8	1	3	4	PH ¹⁾	

- +V: Supply voltage encoder +V DC
- 0 V: Supply voltage encoder ground GND (0 V)
- 0 Vsens / +Vsens: Using the sensor outputs of the encoder, the voltage present can be measured and if necessary increased accordingly.
- A, \bar{A} : Incremental output channel A
- B, \bar{B} : Incremental output channel B
- 0, $\bar{0}$: Reference signal
- PH \perp : Plug connector housing (shield)

Top view of mating side, male contact base

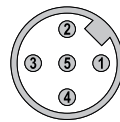

M12 connector, 5-pin

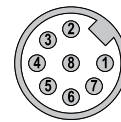

M12 connector, 8-pin

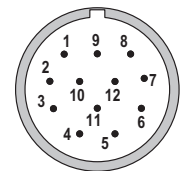

M23 connector, 12-pin

1) PH = shield is attached to connector housing.

Incremental encoders

Standard optical	Sendix Base KIS50 / KIH50 (shaft / hollow shaft)	Push-pull / RS422 / Open collector
-------------------------	---	---

Dimensions shaft version

Dimensions in mm [inch]

Clamping flange, \varnothing 58 [2.28] Flange type 8

1 3 x M3, 6 [0.24] deep

D	Fit	L
6 [0.24]	h7	10 [0.39]
8 [0.32]	h7	15 [0.59]
10 [0.39]	h7	20 [0.79]
12 [0.47]	h7	20 [0.79]

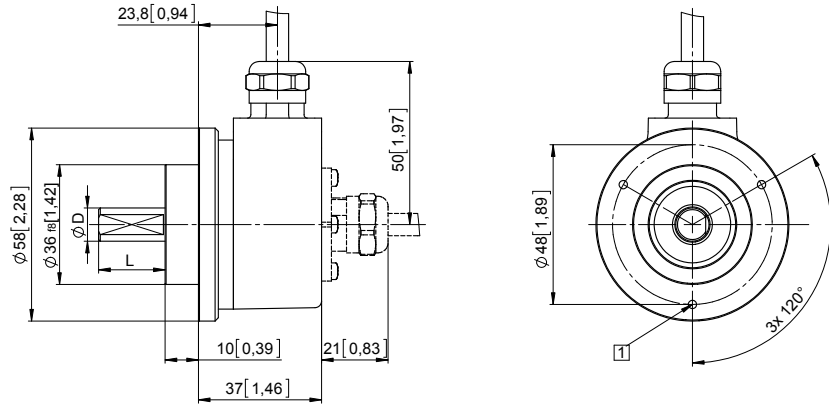

Clamping flange, \varnothing 58 [2.28]

Flange type 8 and shaft \varnothing 10 mm on both sides

1 3 x M3, 6 [0.24] deep

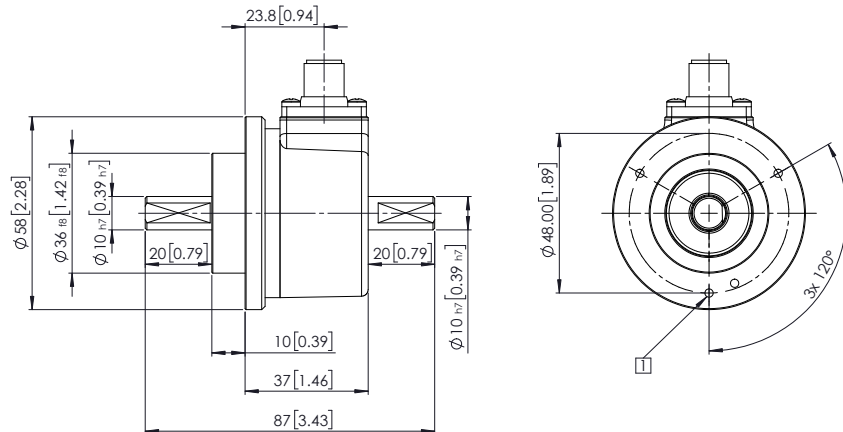

Synchro flange, \varnothing 58 [2.28]

Flange type B

1 3 x M4, 6 [0.24] deep

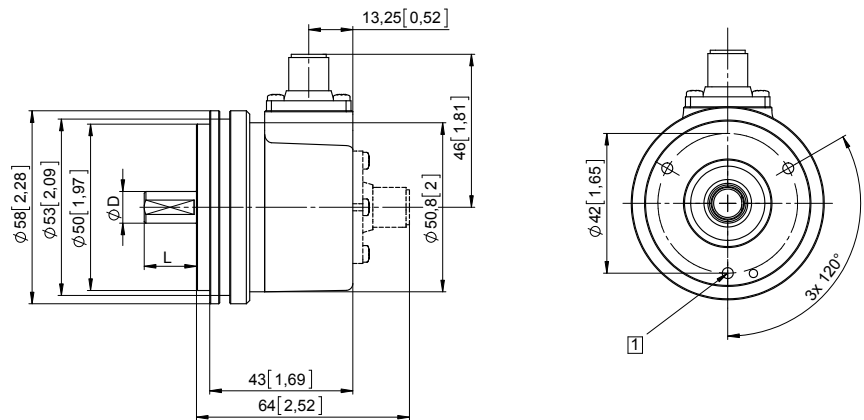

D	Fit	L
6 [0.24]	h7	10 [0.39]
8 [0.32]	h7	15 [0.59]
10 [0.39]	h7	20 [0.79]
12 [0.47]	h7	20 [0.79]

Incremental encoders

Standard optical

Sendix Base KIS50 / KIH50 (shaft / hollow shaft)

Push-pull / RS422 / Open collector

Dimensions hollow shaft version

Dimensions in mm [inch]

Flange with spring element, long Flange type 2

- 1 3 x M3, 6 [0.24] deep
- 2 Slot spring element, recommendation: torque pin DIN 7, \varnothing 4 [0.16]
- 3 Recommended torque for the clamping ring 0.6 Nm

D	Fit
8 [0.32]	H7
10 [0.39]	H7
12 [0.47]	H7
14 [0.55]	H7
15 [0.59]	H7

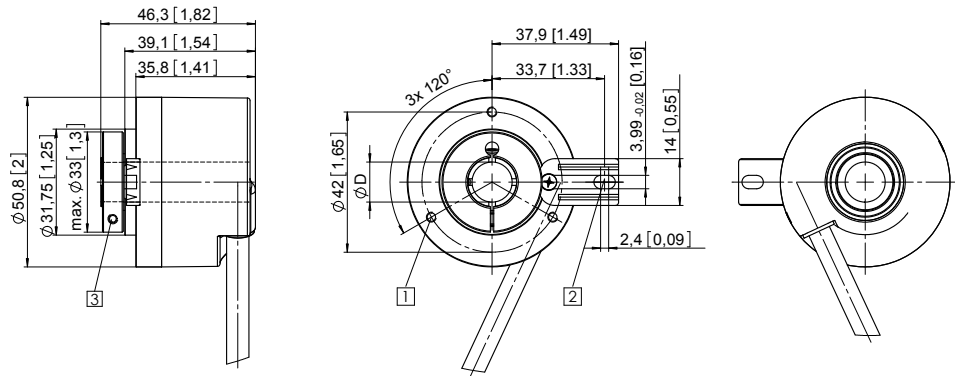

Flange with torque stop, long Flange type 4

- 1 Recommended torque for the clamping ring 0.6 Nm

D	Fit
8 [0.32]	H7
10 [0.39]	H7
12 [0.47]	H7
14 [0.55]	H7
15 [0.59]	H7

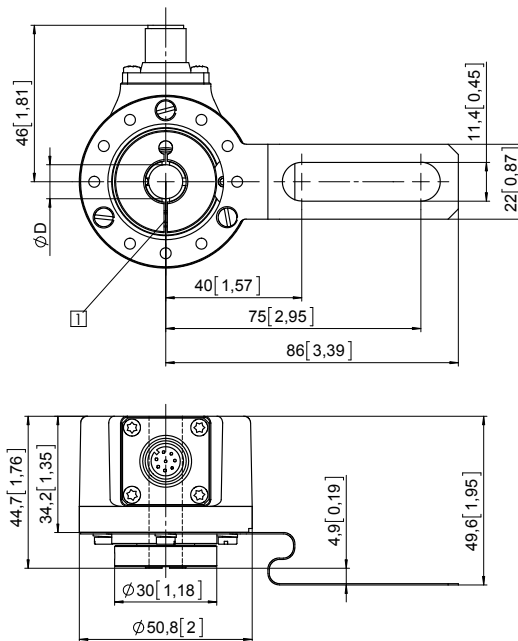

Flange with stator coupling, \varnothing 63 [2.48] Flange type D

- 1 Recommended torque for the clamping ring 0.6 Nm

D	Fit
8 [0.32]	H7
10 [0.39]	H7
12 [0.47]	H7
14 [0.55]	H7
15 [0.59]	H7

