

# Braukmann D15S

## Pressure Reducing Valve Diaphragm-actuated with Cartridge Insert

### Application

According to EN 806-2 pressure reducing valves of this type protect household water installations against excessive pressure from the supply. They can also be used for industrial or commercial applications within the range of their specification.

By installing a pressure reducing valve, pressurization damage is avoided and water consumption is reduced. The set pressure is also maintained constant, even when there is wide inlet pressure fluctuation. Reduction of the operating pressure and maintaining it at a constant level minimizes flow noise in the installation.

The set pressure is also maintained constant, even when there is wide inlet pressure fluctuation.

Reduction of the operating pressure and maintaining it at a constant level minimizes flow noise in the installation.

### Approvals

- DVGW
- WRAS (up to 23 °C)
- KIWA (DN65-DN100)
- SVGW (DN65-DN100)

### Special Features

- LEAD-FREE: Pb content of all materials in contact with medium less than 0.1 %
- Inlet pressure balancing – no influence on outlet pressure by fluctuating inlet pressure
- Patented cartridge solution for easy assembly and maintenance
- Three cartridge inserts for all nominal widths make warehousing efficient
- High corrosion resistance due to stainless steel cartridge and PA coating
- The adjustment spring is not in contact with the drinking water
- With inlet and outlet pressure gauge
- Functionality and performance have been confirmed by an accelerated life test with over 400.000 cycles (requirement acc. to EN 1567: 200.000 cycles)
- Conforms to BSEN 1567
- All materials are UBA conform
- ACS certified
- 5-year warranty



**kiwa**



### Technical Data

<b>Medium</b>	
Medium:	Drinking water
<b>Connections/Sizes</b>	
Connection size:	2" - 8"
Nominal sizes:	DN50 - DN200 DN125 available with adapter flanges DN100/DN125
<b>Pressure values</b>	
Max. inlet pressure:	16 bar
Outlet pressure:	DN 50 - 100: 1.5 - 7.5 bar DN 150 - 200: 1.5 - 8 bar
Nominal pressure:	PN16
Min. pressure drop:	1 bar
<b>Operating temperatures</b>	
Max. operating temperature medium:	65 °C
Max. operating temperature medium accord. to EN 1567:	30 °C

## Construction

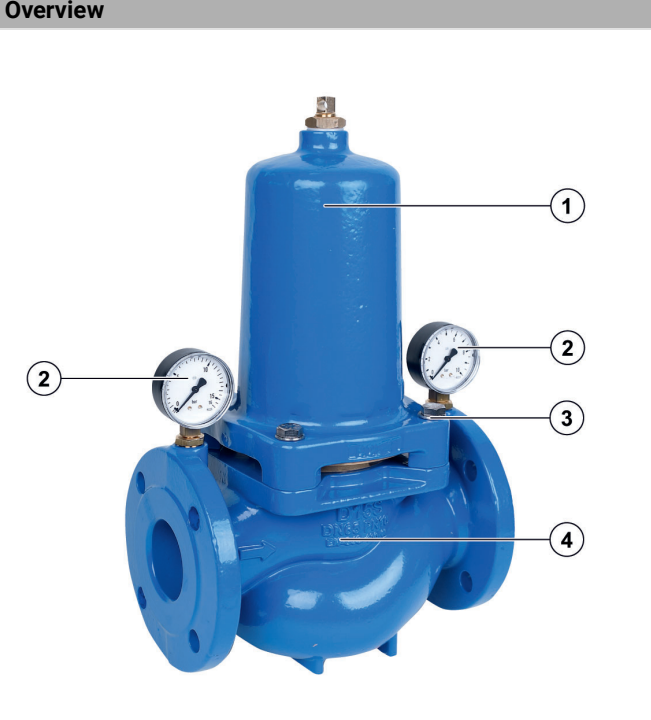
Overview	Components	Materials	
	1	Spring bonnet with adjustment screw	Ductile cast iron (EN-GJS-400-15 EN 1563), coated with PA (polyamide)
	2	Pressure gauge	-
	3	Screws and nuts	Stainless steel
	4	Housing with flanges per ISO 7005-2, EN 1092-2, face to face length acc. EN 558-1	Ductile cast iron (EN-GJS-400-15 EN 1563), coated with PA (polyamide)
<b>Not depicted components:</b>			
		Adjustment spring	Spring steel
		Diaphragm and seals	EPDM
		Cartridge insert	Stainless steel
		Groove ring and sealing disc	EPDM

## Method of Operation

Spring loaded pressure reducing valves operate by means of a force equalising system. The force of a diaphragm operates against the force of an adjustment spring. If the outlet pressure and therefore diaphragm force fall because water is drawn, the then greater force of the spring causes the valve to open. The outlet pressure then increases until the forces between the diaphragm and the spring are equal again.

The inlet pressure has no influence in either opening or closing of the valve. Because of this, inlet pressure fluctuation does not influence the outlet pressure, thus providing inlet pressure balancing.

## Transportation and Storage

Keep parts in their original packaging and unpack them shortly before use.

The following parameters apply during transportation and storage:

Parameter	Value
Environment:	clean, dry and dust free
Min. ambient temperature:	5 °C
Max. ambient temperature:	55 °C
Min. ambient relative humidity:	25 % *
Max. ambient relative humidity:	85 % *

\*non condensing

## Installation Guidelines

### Setup requirements

- Install in horizontal pipework with spring bonnet directed upwards
- Installation in vertical pipework possible with increased maintenance effort
- Install shut-off valves
- The installation location should be protected against frost and be easily accessible
  - Pressure gauge can be read off easily
  - Simplified maintenance and cleaning
- Install downstream of the filter or strainer
  - This position ensures optimum protection for the pressure reducing valve against dirt
- Provide a straight section of pipework of at least five times the nominal valve size after the pressure reducing valve (in accordance with EN 806-2)
- Requires regular maintenance in accordance with EN 806-5

**Installation Example**

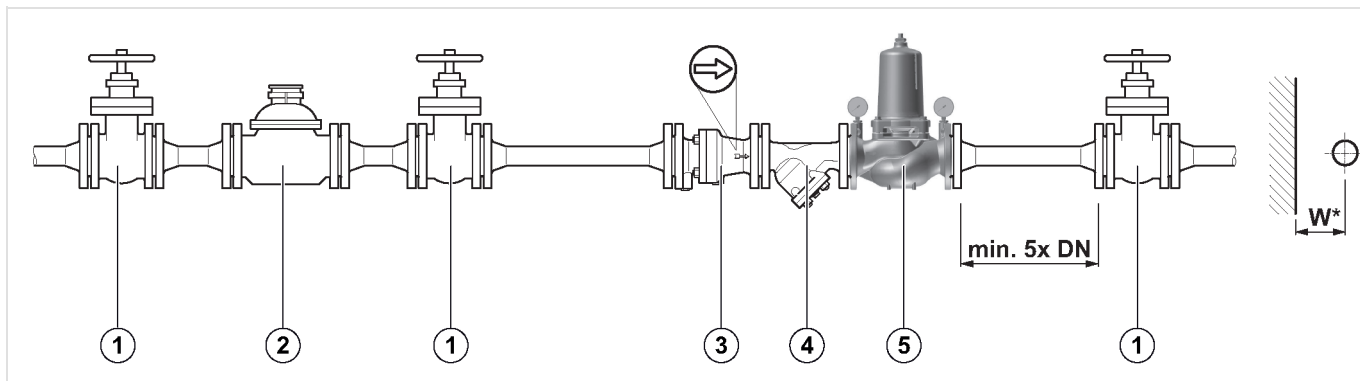

Fig. 1 Standard installation example for the pressure reducing valve

- 1 Shut-off valve
- 2 Water meter
- 3 Non return valve
- 4 Strainer
- 5 Pressure reducing valve

Connection size:						
DN	50	65	80	100	150	200
inch	2"	2 1/2"	3"	4"	6"	8"
Distance in mm (W*):	110	120	130	145	200	230

\* Required installation distances between the centerline of the pipework and the surrounding in dependency of the connection size.

**Technical Characteristics**

**kvs-Values**

Connection size:						
DN	50	65	80	100	150	200
Inch	2"	2 1/2"	3"	4"	6"	8"
DVGW registration number:	requested	NW-6330CN0112			n.a.	
k <sub>VS</sub> -value (m <sup>3</sup> /h):	18	49	51	56	230	255

**Pressure drop characteristics**

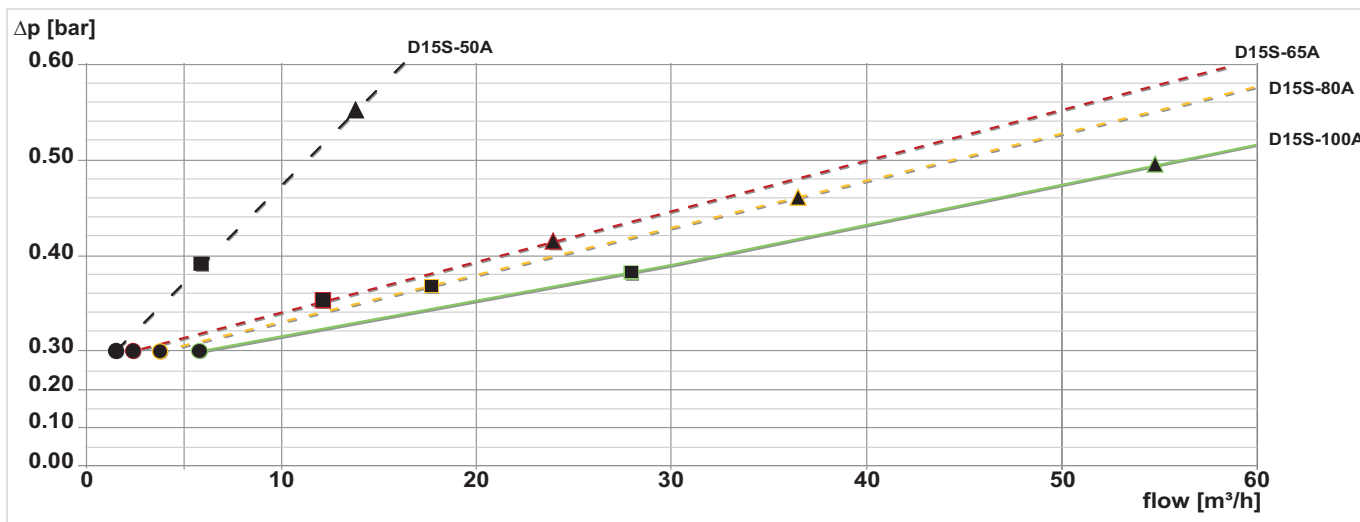

Fig. 2 Pressure drop within the valve in dependency of the flow rate and the used connection size (Sizes 50-100)  
 Pressure setting: P1: 8 bar, P2: 3 bar

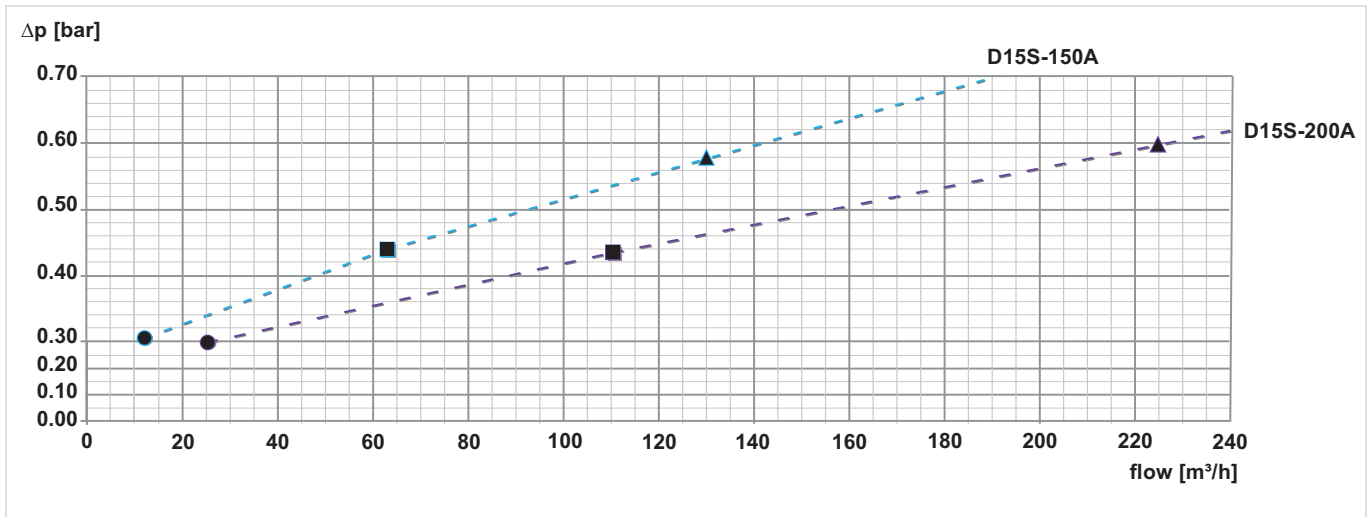
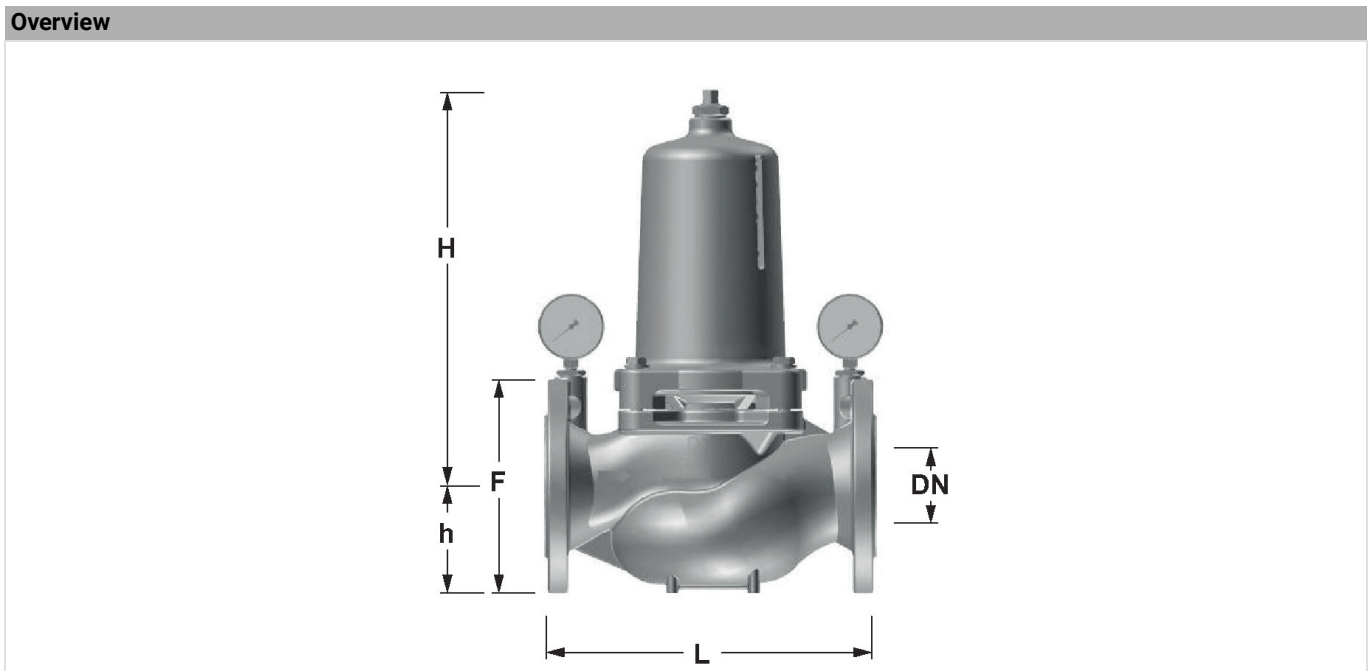

Fig. 3 Pressure drop within the valve in dependency of the flow rate and the used connection size (Sizes 150-200)  
 Pressure setting: P1: 8 bar, P2: 3 bar

**Flow Rate**

Nominal size diameter	DN50	DN65	DN80	DN100	DN150	DN200
● $\cong$ 10 % of standard flow	1.4 m³/h	2.4 m³/h	3.6 m³/h	5.6 m³/h	12.7 m³/h	22.6 m³/h
■ $\cong$ 1 m/s flow rate	7 m³/h	12 m³/h	18 m³/h	28 m³/h	63 m³/h	113 m³/h
▲ $\cong$ 2 m/s flow rate = QN	14 m³/h	24 m³/h	36 m³/h	56 m³/h	127 m³/h	226 m³/h
Flow rate 4 m/s flow velocity	28 m³/h	48 m³/h	72 m³/h	112 m³/h	254 m³/h	452 m³/h

**Dimensions**



Parameter	Values						
Nominal sizes:	DN	50	65	80	100	150	200
Connection size:	Inch	2"	2 1/2"	3"	4"	6"	8"
Weight:	kg	14	30.5	32	34.5	110	135
Dimensions:	L	230	290	310	350	480	600
	H	296	370	370	370	541	534
	h	83	93	100	110	143	170
	F	165	185	200	220	285	340

Note: All dimensions in mm unless stated otherwise.

## Ordering Information

The following tables contain all the information you need to make an order of an item of your choice.

### Options

The valve is available in the following sizes: 2", 2<sup>1</sup>/<sub>2</sub>", 3", 4", 6" and 8".

- standard
- not available

		D15S-...A
Flanges:	PN16, ISO 7005-2, EN 1092-2, face to face length acc. EN 558-1	•
Housing:	Ductile cast iron (EN-GJS-400-15 EN 1563), coated with PA (polyamide)	•

Note: ... = space holder for connection size

Note: Item number example for 2<sup>1</sup>/<sub>2</sub>" and type A valve: D15S-65A

### Accessories

	Description	Dimension	Item No.
	<b>EXF125-A Extension flange DN125</b> Adapter flanges DN100 to DN125 Ductile iron, PN16 acc. ISO 7005-2 and EN 1092-2. Overall length with adapter flanges (without bolts) DN125 L=416mm, including bolts, nuts and the seal disc.		
			EXF125-A

**Spare Parts**

Pressure Reducing Valve D15S, from 2012 onwards

**Overview**

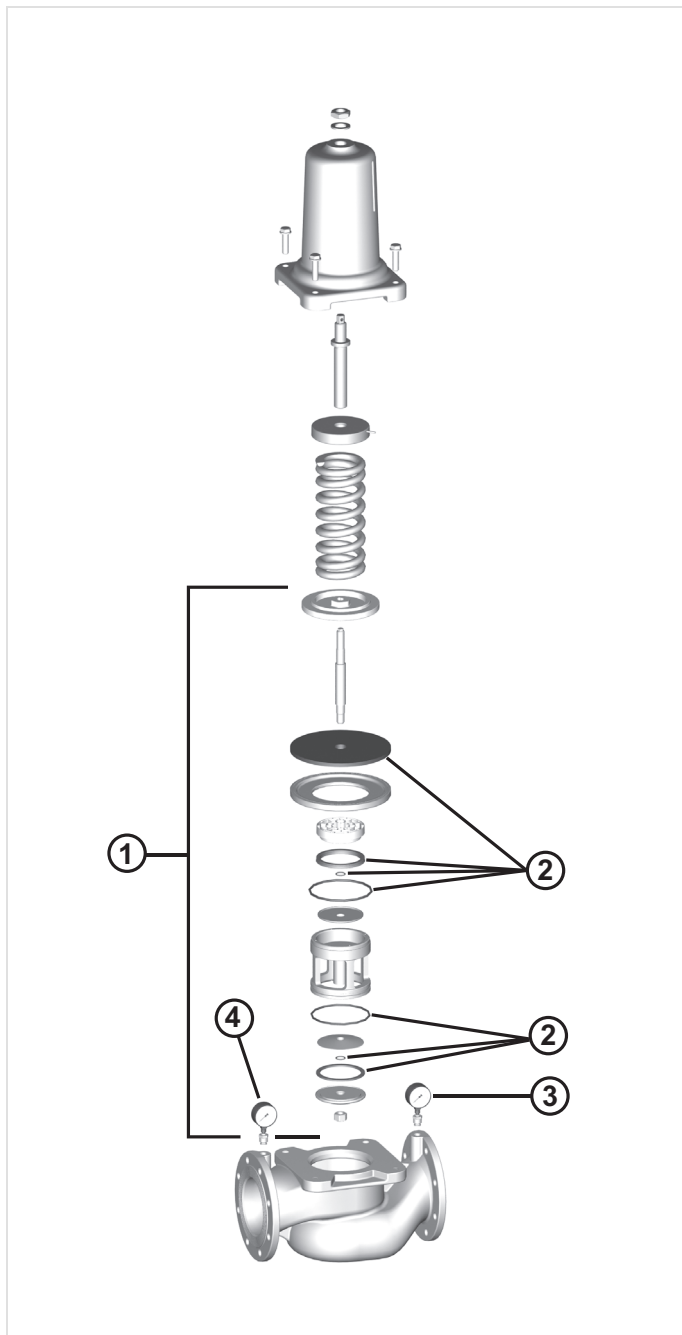

Description	Dimension	Item No.
<b>1 Valve insert complete</b>		
	DN50	0904175
until 03/2020	DN65 - DN100	D15S-SET-OT
as of 03/2020	DN65 - DN100	0904220
	DN150 - DN200	0904139
<b>2 Set of seals complete</b>		
	DN50	0904176
	DN65 - DN100	0904221
	DN150 - DN200	0904140
<b>3 Pressure gauge</b>		
	0 - 10 bar	M39M-A10
<b>4 Pressure gauge</b>		
	0 - 16 bar	M39M-A16