



Avtron HS35A Encoders



Light Mill Duty Optical Hollow Shaft Encoder: 1/2"-1" [12mm-25mm]

Optical Precision in a Compact Encoder

- Fits shafts 1/2" to 1"
- Simple Installation
- Up to 5000 PPR
- Unbreakable Optical Disk
- Wide-Gap Technology: Up to 8X larger gap between sensor and rotor
- Replaces Competitive Models without Rewiring
- Fits end of shaft and through shaft applications
- IP65/Nema 4, 13 Rating: Dust and Liquid Tight
- Superior Bearings and Seals
- 20°C to +100°C Operation *
- 2 Year No-Hassle Warranty

HS35A

HS35A encoders fit shafts from 1/2" to 1" easily, using a durable shaft insert. Units may be resized by replacing or removing the insert, enabling our factory, distributors, and customer stockrooms to swiftly meet any need. The shaft insert and insulated bearings also provide isolation from motor shaft currents, while permitting case grounding to meet NEC requirements.

Avtron encoders have superior shaft seals and bearings that stay sealed to keep out contamination caused by temperature cycling and liquid sprays. Our encoder seals are protected by mechanical barriers to prevent flexing or failure, and Avtron's superior bearings feature synthetic lubricants for even longer life.

Many competitive optical encoder designs risk sensor damage from any vibration or shock: sensors ride less than four thousandths of an inch from the thin, often flexible, optical disk spinning at full motor speeds. Some designs even use thin glass disks in "industrial" products! Avtron uses only unbreakable disks and a sensor to disk gap over 8X larger than the competition.

Our optical HS35A encoders use superior sensor, disk, bearing, and seal technology to give top performance in industrial conditions. Select an Avtron HS35A today!

OUTLINE DRAWING

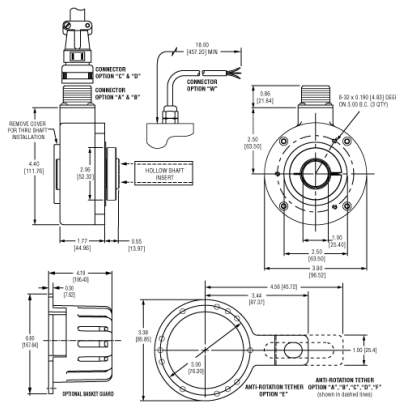

MORE HS35A ADVANTAGES

- All digital, fully integrated design
- No mechanical adjustments or trim potentiometers
- Innovative shaft ring retains collar during installation
- Advanced sensor technology
- Superior bearings with synthetic lubricant for longer life
- No extra charge for signal complements and marker pulse (A,A-, B,B-, Z,Z-)
- Insulated from motor shaft currents
- Models can be resized by interchanging inserts
- Optional basket guard adds even more protection

MORE HS35A SPECIFICATIONS

Operating Power: Volts: 5 - 28 VDC; Current: 50mA, no load

Output Format: A Quad B with marker (A, /A, B, /B, Z, /Z)

Frequency Range: 0 to 125 kHz

PPR: 100 - 5000 standard

Speed: 6000 RPM Max., (for higher speeds, consult factory)

Temperature: -20° to 100°C*

Environmental: IP65

Vibration: 5-2000Hz

Shock: 50G, 11ms duration

Weight: 1.6 lbs [730g]

All dimensions are in inches [millimeters].

Specifications and features are subject to change without notice.

* Please consult factory for temperature/speed derating

Check out our website for more detailed specifications, drawings, and installation instructions. www.avtronencoders.com

SELECTION GUIDE

MODEL	PPR	LINE DRIVER	HOLLOW SHAFT BORE SIZE	CONNECTOR OPTIONS	MOUNTING	PROTECTION	ANTI-ROTATIONAL TETHER	CHANNELS	MODIFICATIONS
HS35A	G - 100 PPR K - 200 PPR L - 240 PPR M - 250 PPR E - 360 PPR Q - 500 PPR R - 512 PPR S - 600 PPR V - 900 PPR W - 1000 PPR Y - 1024 PPR Z - 1200 PPR 3 - 2000 PPR 4 - 2048 PPR 5 - 2500 PPR 8 - 4000 PPR D - 4096 PPR 9 - 5000 PPR	1 - 5-28v In/Out (7272) 2 - 5-28v In/OC Out (7273) 4 - 5-28v In, 5v Out (7272)	B - 1/2 in. bore via insert C - 5/8 in. bore via insert D - 3/4 in. bore via insert E - 7/8 in. bore via insert F - 1 in. native bore U - 1/2 in. thru 1 in bore (Universal USA) P - 12mm via insert Q - 14mm via insert R - 15mm via insert S - 16mm via insert V - 19mm via insert W - 20mm via insert Y - 25mm native bore Z - 12mm thru 20mm bore (Universal metric)	A - 10 pin MS style w/o Plug, Avtron/BEI Phasing B - 10 pin MS style w/o Plug, Dynapar HS35 Phasing C - 10 pin MS style w/Plug, Avtron/BEI Phasing D - 10 pin MS style w/Plug, Dynapar HS35 Phasing E - 6 pin MS style w/o Plug, Avtron/BEI Phasing F - 6 pin MS style w/o Plug, Dynapar HS35 Phasing G - 6 pin MS style w/Plug, Avtron/BEI Phasing H - 6 pin MS style w/Plug, Dynapar HS35 Phasing J - 7 pin MS style w/o Plug, Avtron/BEI Phasing K - 7 pin MS style w/o Plug, Dynapar HS35 Phasing M - 7 pin MS style w/Plug, Avtron/BEI Phasing N - 7 pin MS style w/Plug, Dynapar HS35 Phasing R - 10 pin Mini-MS style Twist-Lock (Baldor/Bayonet Style) w/o plug, Avtron/BEI Phasing S - 10 pin Mini-MS style Twist-Lock (Baldor/Bayonet Style) w/o plug, Avtron/BEI Phasing on cable T - M12/8 pin Turck Pinout w/o plug U - M12/8 pin US Pinout w/o plug V - M12/8 pin US Pinout w/ plug W - M12/8 pin US Pinout w/ plug 7 - M12/8 pin US Pinout w/ plug Reverse Phasing W - Cable (18 in. or special length) Y - 18 inch Sealed Cable with Flying Leads, BEI Color Code Z - Mini-Epic Style Connector with Plug, on 18" Cable 1 - 15 pin D-SUB on cable 2 - M23/12 pin CW Pinout w/o plug Avtron Phasing	U - Universal (Thru & End of Shaft) X - No rear cover cap, thru or end of shaft mounting	0 - None 1 - Basket	X - No Tether A - 1/4 in.-20 T-Bolt Fan Cover Tether B - 5/16 in.-18 T-Bolt Fan Cover Tether C - 3/8 in.-16 T-Bolt Fan Cover Tether D - All T-bolt Fan Cover Tethers E - 4.5 in. C-Face Tether F - 8.5 in. C-Face Tether G - 12 in. Threaded Rod Tether M - Fan cover & 4.5" C-face mount N - Marker-pulse-orienting Tether R - Pin & Block, BEI compatible U - A-F All Tethers	A - All Channels (A, A/, B, B/, Z, Z/) B - A, /A, B, /B (complements, no marker) D - A, /A (single phase w/complement, no marker) E - A, B, Z (no complements, marker) F - A, B (no complements, no marker)	000 - No Special Features 00W - Connector on Cable (obsolete but still available-use W00 or WXX option) W00 - Connector on 18" Cable W01 - Connector on 1 ft Cable 901 - 1 ft. /0.3m Cable 902 - 2 ft./0.6m Cable 903 - 3 ft./0.9m Cable 904 - 4 ft./1.2m Cable 905 - 5 ft./1.5m Cable 910 - 10 ft./3m Cable 915 - 15 ft./4.5m Cable 920 - 20 ft./6m Cable 925 - 25 ft./7.5m Cable 933 - 33 ft./10m Cable 930 - 30 ft./9m Cable