



Sample gas pumps P 2.3, P 2.3C, P 2.83, P 2.4, P 2.4C, P 2.84

Gas analysis is key for safe and efficient system operation in the chemical industry, petrochemistry or biochemistry. Many of the analysis processes used in these fields require sample gas extraction and conditioning.

Sample gas pumps convey the sample gas from the sampling point to the conditioning system. The main item in these pumps designed specifically for the application is the PTFE single-piece bellows. Combined with the pump head, also single-piece, this solution provides high resistance against particularly aggressive sample gas. Turning the pump head allows gas with condensate to be conveyed without a problem.

Simple, sturdy construction

Easy to replace valves

Single-piece bellows

Conveys sample gas with condensate

Long life

Atex versions (see separate data sheet)

Low noise emission

115 V - versions with FM C-US approval

C-versions specifically for conveying flammable gasses

Bypass valve for PTFE and VA pump body

General specifications for all pumps

General Specifications

Nominal voltage:	see ordering information
Protection class:	electric IP55 mechanical IP20
Dead volume:	8.5 ml
Materials of parts in contact with media by pump type:	PTFE / PVDF (standard pump with 100 °C valves) + PEEK (standard pump with 160 °C valves) + Viton (standard pump with 100 °C valves and bypass valve) + PCTFE, Viton (standard pump with 160 °C valves and bypass valve) + 1.4571 (VA pump body) + 1.4401, Viton (VA pipe fitting) + Viton (VA pump body with bypass valve)

Feed Curves

P2.3, P2.3C, P2.4, P2.4C

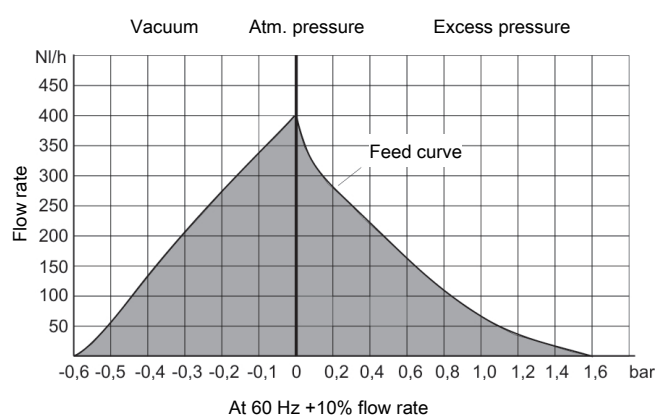

P2.83, P2.84

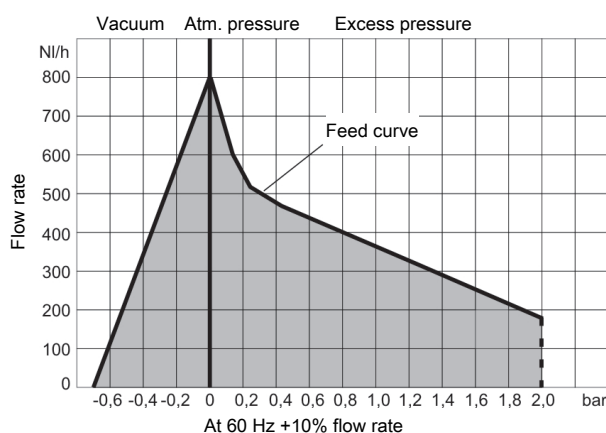

P2.3 and P2.83 Pump Models

For easier installation, the P2.3 and P2.83 pumps include a mounting bracket with rubber mounting.

The pump head can optionally be ordered with adjustable bypass valve.

The difference between the P2.3 and P2.83 is the flow rate. The P2.3 pump has a capacity of 400 L/h free flow and the P2.83 has a capacity of 800 L/h free flow.

The P2.3 and P2.83 pumps are not suitable for use in explosive areas. The corresponding types for use in explosive areas are P2.2 ATEX (data sheet 420009), P2.2 AMEX and P2.82 AMEX (data sheet 420012), or US-P2.6Ex (data sheet 420005).

Technical data for P2.3 and P2.83

P2.3/P2.83 Technical Data

Weight:	approx. 6.5 kg
FM C-US (115 V only)	
FM approval no.:	3038101/3038101C
Ambient temperature:	max. 60 °C
Media temperature:	PTFE/PVDF valves max. 100 °C PTFE/PEEK valves max. 160 °C

P2.4 and P2.84 Pump Models

When installed inside an electric cabinet, wall thicknesses of up to 30 mm can be bridged without additional modifications.

The difference between the P2.4 and P2.84 is the flow rate. The P2.4 pump has a capacity of 400 L/h free flow and the P2.84 has a capacity of 800 L/h free flow.

The P2.4 and P2.84 pumps are not suitable for use in explosive areas. The corresponding types for use in explosive areas are P2.4 ATEX (data sheet 420009), P2.4 AMEX and P2.84 AMEX (data sheet 420012).

Technical data for P2.4 and P2.84

P2.4/P2.84 Technical Data

Weight:	approx. 7 kg
FM C-US (115 V only)	
FM approval no.:	3038101/3038101C
Ambient temperature	
Motor:	max. 60 °C
Pump head:	max. 100 °C
Media temperature:	PTFE/PEEK valves max. 160 °C

P2.3C and P2.4C Pump Models

Pump models P2.3C and P2.4C are suitable for conveying flammable gasses in zone 2. The pumps are not suitable for use in explosive areas according to Atex.

Technical data for P2.3C and P2.4C

P2.3C/P2.4C Technical Data

Weight	
P2.3 C:	approx. 6.5 kg
P2.4 C:	approx. 7 kg
Marking:	Ⓔ II 3G/- Ex h IIB T4 Gc
Ambient temperature	
Motor:	max. 50 °C
Pump head:	see table
Medium temperature:	see table

NOTICE! The devices are not suitable for use in explosive areas!

Temperature classes for P2.3C and P2.4C

P 2.3C	Medium temperature		
no flammable gasses in the gas circuit		see P2.3/P.283	
Flammable gasses in the gas circuit above the LEL	T3	120 °C	
	T4	50 °C	
P 2.4C	Medium temperature	Pump head temperature	
no flammable gasses in the gas circuit		see P2.4/P2.84	
Flammable gasses in the gas circuit above the LEL	T3	100 °C	80 °C
	T4	50 °C	50 °C

P2.3, P2.4, P2.83, P2.84 Ordering instructions

42	xx	x	x	x	x	x	9	0	0	0	Product characteristic
Base model											
56											P2.3 400 L/h (direct operation without intermediate flange)
57											P2.4 400 L/h (with intermediate flange)
63											P2.83 800 L/h (direct operation without intermediate flange)
64											P2.84 800 L/h (with intermediate flange)
Motor voltage											
1											230 V 50/60 Hz; 0,78/0,86 A
2											115 V 50/60 Hz; 1,56/1,72 A
5											400 V 50 Hz; 0,52 A
Pump head position											
1											Normal position vertical
2											turned by 180° ¹⁾
Pump body material											
1											PTFE
2											Stainless steel 1.4571
3											PTFE with bypass valve ¹⁾
4											Stainless steel 1.4571 with bypass valve ¹⁾
Valve material											
1											up to 100 °C; PTFE/PVDF ²⁾
2											up to 160 °C; PTFE/PEEK
Screw-in connections (for 230 V and 400 V voltage)											
						PTFE Pump body		Stainless steel pump body			
9						DN 4/6 (Standard)		6 mm (Standard)			
1						DN 6/8		8 mm			
2						3/8"-1/4"		3/8"			
3						1/4"-1/8"					
4						1/4"-1/6"		1/4"			
Screw-in connections (for 115 V voltage)											
						PTFE Pump body		Stainless steel pump body			
9						1/4"-1/6" (Standard)		1/4" (Standard)			
1						DN 6/8		8 mm			
2						3/8"-1/4"		3/8"			
3						1/4"-1/8"					
5						DN 4/6		6 mm			
Mounting accessories											
9						incl. mounting bracket and bumper ¹⁾					

¹⁾ not for P2.4 & P2.84.

²⁾ not for P2.4, P2.83 & P2.84.

P2.3C, P2.4C Ordering instructions

42	xx	x	x	x	x	x	9	0	00	Product characteristic	
										Base model	
52										P2.3C 400 l/h (II 3G/- Ex h IIB T4 Gc) (direct operation without intermediate flange)	
53										P2.4C 400 l/h (II 3G/- Ex h IIB T4 Gc) (with intermediate flange)	
										Motor voltage	
1										230 V 50/60 Hz; 0,78/0,86 A	
2										115 V 50/60 Hz; 1,56/1,72 A	
5										400 V 50 Hz; 0,52 A	
										Pump head position	
1										Normal position vertical	
2										turned by 180° *	
										Pump body material	
1										PTFE	
2										Stainless steel 1.4571	
3										PTFE with bypass valve *	
4										Stainless steel 1.4571 with bypass valve *	
										Valve material	
1										up to 100 °C; PTFE / PVDF *	
2										up to 160 °C; PTFE / PEEK	
										Screw-in connections (for 230 V and 400 V voltage)	
										PTFE Pump body	
										Stainless steel pump body	
9										DN 4/6 (Standard)	6 mm (Standard)
1										DN 6/8	8 mm
2										3/8"-1/4"	3/8"
3										1/4"-1/8"	
4										1/4"-1/6"	1/4"
										Screw-in connections (for 115 V voltage)	
										PTFE Pump body	Stainless steel pump body
9										1/4"-1/6" (Standard)	1/4" (Standard)
1										DN 6/8	8 mm
2										3/8"-1/4"	3/8"
3										1/4"-1/8"	
5										DN 4/6	6 mm
										Mounting accessories	
9										incl. mounting bracket and bumper *	

*not applicable to 2.4C

Ordering example

Item no.: 42 63 1112 99 000

- 63 for 800 litre P2.83 pump
- 1 for 230V 50/60Hz motor
- 1 for pump head in normal position
- 1 PTFE pump head
- 2 for 160 °C valves
- 9 for DN4/6 screw-in connection
- 9 includes mounting bracket and bumpers

Dimensions

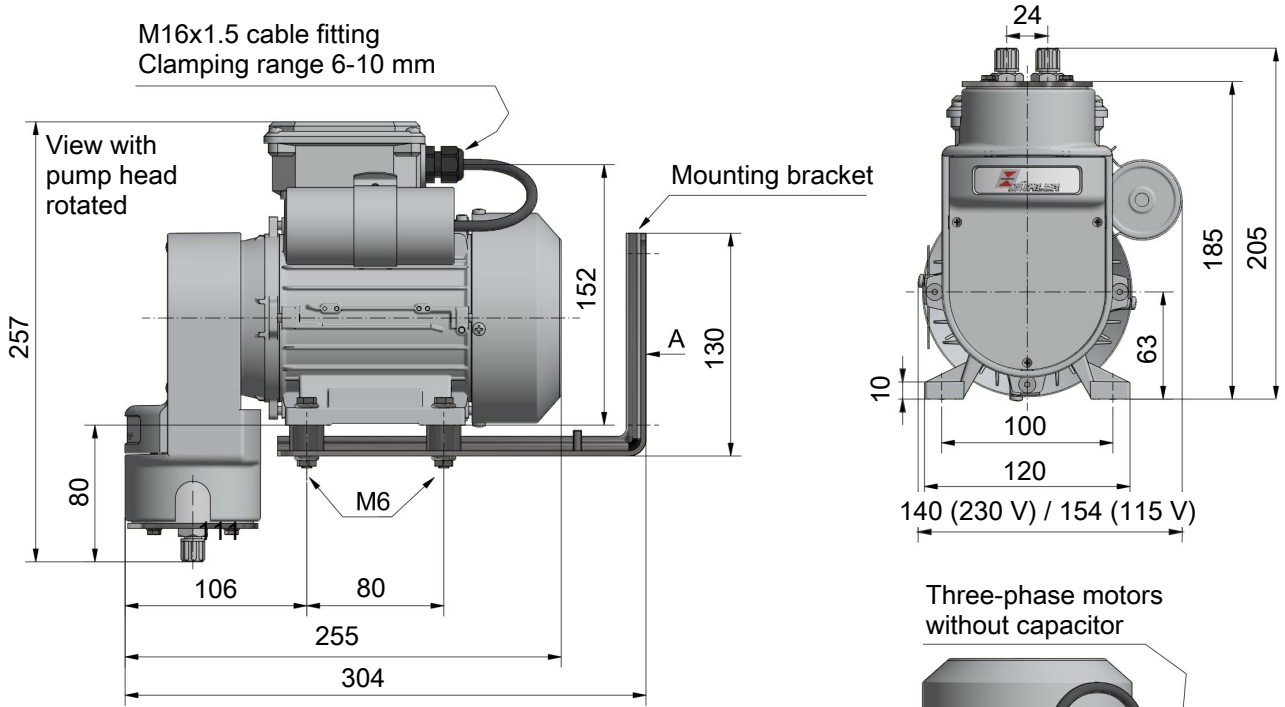

Three-phase motors without capacitor

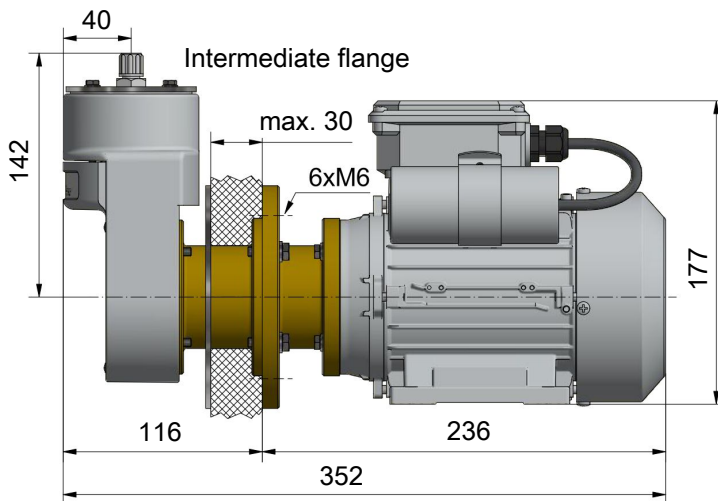
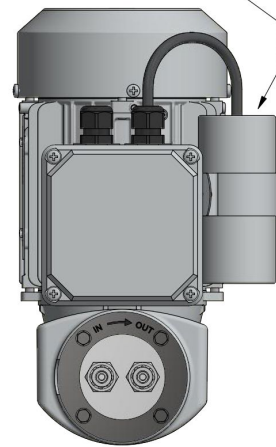

Cabinet cut-out for pumps with intermediate flange

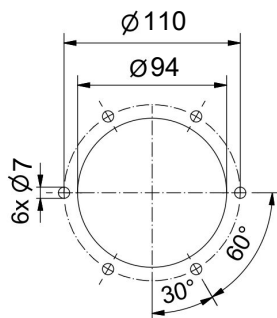

Adjustable bypass valve (optional)

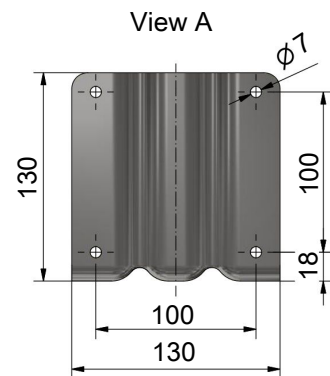
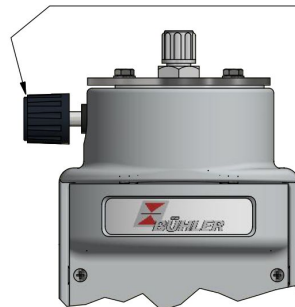

Installation notices:

- 1) This pump should be installed horizontally
- 2) If necessary, rotate the pump head during installation. When conveying gasses with condensate content it must be installed valves down.