

# PRESSURE RELIEF VALVES

## How It Works

The function of a Pressure Relief Valve is to protect against overpressure. For safety reasons, excessive overpressure in any part of the refrigeration system must be avoided.

## Applications

Henry PRVs are designed to protect system components such as receivers, heat exchangers and vessels from dangerous overpressure. Uncontrolled pressure increase inside a system can occur due to refrigerant expansion as a result of fire, other heat sources or compressor overrun. In these scenarios, the PRV will discharge, lowering the system pressure back to safe levels, before closing again.

Henry Group's PRVs are designed to discharge vapour and should not be used to vent liquid refrigerant. The valves are "back-pressure dependent" and therefore required to discharge to atmospheric pressure.

All models are suitable for use with HCFC, HFC, HFO, CO<sub>2</sub> and R290 refrigerants along with their associated oils where materially compatible. Stainless steel models in the Standard range as well as in our dedicated Ammonia range models, are suitable for use with R717 & associated oils, where materially compatible.

It is recommended to have a relief pressure setting at least 25% higher than the maximum system operating pressure. The PRV set pressure should not be higher than the design pressure (MWP) of the vessel.

## Main Features

- Category IV PED & PE(S)R Certified (CE & UKCA) marks
- ASME Certified (ASME-UV & NB stamps)
- Set Pressure Tolerance = +/-3%
- Maximum Overpressure = 10%
- Proven Safe Design
- Precision Machined Parts for Maximum Reliability
- Compact Design
- Blow-Out Proof Seal Design
- Tamper Proof

## Maintenance & Service Life

Henry PRVs are designed to be maintenance free and are secured with a tamper proof security seal once set at the factory. Removal of the seal, or any attempt to service or replace components of the PRV, will void the product warranty.

In-line with the Institute of Refrigeration Guidelines (UK), Henry Group recommends that a PRV should be replaced at least every five years. These intervals may have to be reduced if other regulations are applied.

Once a PRV has discharged, replacement is recommended as set pressure can no longer be guaranteed. This is due to the likely presence of system debris & particles embedding into the valve seat during discharge, as well as the force of the re-closing action itself.

## Certification

All of Henry Group's PRVs are supplied with an electronic instruction sheet, which can be accessed directly via the QR code or web address that is printed on the box. The Instruction Sheets contain a guide explaining how to access and download the electronic EU/UK DoC for a specific valve.



## Customisation

Henry Group PRVs can be customised to meet individual system or regulatory requirements in the following ways:

- A number of common valve and pressure setting combinations are produced as standard models - built to stock. If a system requires an uncommon pressure setting, non-standard pressures are available on all valve models on request.
- All PRVs are supplied with an EU Declaration of Conformity as standard. If local regulations or insurance providers require a bespoke test certificate, these can be provided and linked via serial number to a specific valve.
- All models except the 526E can be ordered and marked with either metric (Barg and kg Air/min) or imperial (PSIg and lbs Air/min) units as required.

## Installation Notes

1. Connect the PRV at a location above the liquid refrigerant level in the vapour space.
2. Stop valves should not be located between the vessel and the PRV, except the three-way dual shut-off type.
3. Do not discharge the PRV prior to installation or when pressure testing the system. The EN 378 Standard advises that PRVs should be removed or isolated during the system pressure test.
4. PRVs should be mounted as close to vertical as possible to avoid the possibility of liquid refrigerant or oil pooling at the valve inlet.
5. The pipe work must not impose loads on the PRV. Loads can occur due to misalignment, thermal expansion, discharge gas thrust etc.
6. Henry PRVs are 'back pressure dependant', meaning that they are designed to discharge to atmospheric pressure. Any built-up back pressure due to outlet piping should be limited to a maximum of 10% as stipulated in the European Standard EN 13136.
7. It is recommended to implement measures discouraging liquid (including rain) from entering the outlet of the valve and pooling inside it. For external installations, attaching a short elbow fitting to the outlet is common practice - noting point 6 above on back pressure.
8. On transcritical CO<sub>2</sub> systems, any discharge piping should be sized with the shortest length and largest bore diameter practical to avoid solids forming downstream of the PRV during a discharge.



# PRESSURE RELIEF VALVES: STANDARD RANGE

## How It Works

A conventional PRV will start to lift within +/-3% of the stamped set pressure. This set point is defined by a minimum of one bubble per second when testing to API standard 527. Following this initial lift the valve will then “pop” fully open within a further 10%. This is achieved through the design of the valve internals, which utilise local static pressure increases and fluid flow phenomena to achieve the characteristic pop action. Once pressure in the system decreases to a safe level, the spring in the PRV will force the valve to re-close again, ensuring some system charge is maintained. A PRV is a safety device and should only be open under abnormal system operating conditions.

## Materials of Construction

- For all 52 models, the main pressure shell of the valve (body & outlet) is made from brass. Valve internal components are made from brass, plated steel or stainless steel.
- For all 53 models, the main pressure shell of the valve (body & outlet) is made from stainless steel. Valve internal components are made from plated steel or stainless steel.
- All models use a non-stick and chemically-inert bespoke PTFE seal.

## Technical Specification

All models are fully designed and certified to ASME BPV XIII, with the exception of the 526E, which is designed to the intent of the same code.

Set pressure range:

10.3 barg to 31.0 barg\*  
150 PSig to 450 PSig\*

52 Temperature range:

-40°C to +107°C  
-40°F to +225°F

53 Temperature range:

-29°C to +135°C  
-20°F to +275°F

\*526E, 5230A, 5231A & 5231B minimum pressure setting is 14.0 barg (203 PSig)

5244, 5244A, 5244P, 5344 & 5344A maximum pressure setting is 27.6 barg (400 PSig)

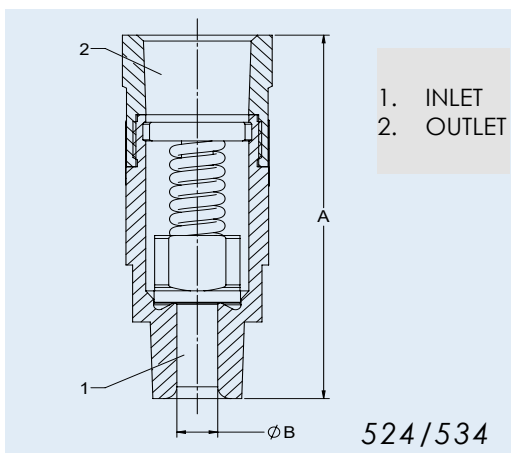
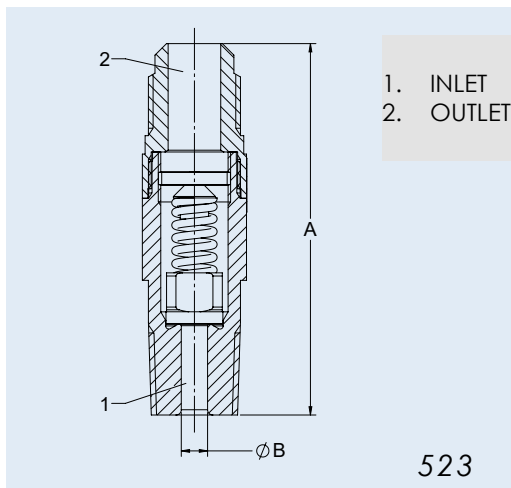
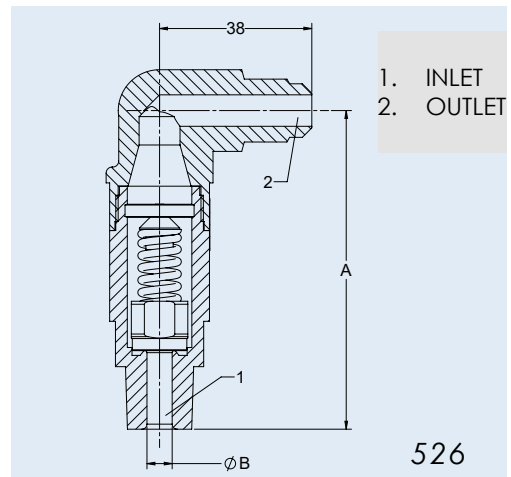



Relief Valves - Brass									
Model	Connection Type		Dimensions (mm)		Flow Area (mm <sup>2</sup> )	K <sub>dr</sub>	Weight (kg)	ASME UV	CE/UKCA Cat
	Inlet	Outlet	A	ØB					
526E	3/8" NPTF	3/8" SAE Flare	80	6.35	31.67	0.41	0.3	No	Cat IV
5230A	1/4" NPTF	1/2" SAE Flare	84	6.35	31.67	0.69	0.2	Yes	
5231A	3/8" NPTF	1/2" SAE Flare	84	6.35	31.67	0.69	0.2	Yes	
5231B	1/2" NPTF	5/8" SAE Flare	90	6.35	31.67	0.69	0.2	Yes	
5232A	1/2" NPTF	3/4" SAE Flare	108	9.53	71.26	0.67	0.4	Yes	
5240	1/2" NPTF	3/4" NPTF (Female)	94	9.53	71.26	0.67	0.4	Yes	
5242	3/4" NPTF	3/4" NPTF (Female)	94	9.53	71.26	0.67	0.5	Yes	
5244A	3/4" NPTF	1" NPTF (Female)	105	12.70	126.68	0.70	0.7	Yes	
5244	1" NPTF	1" NPTF (Female)	105	12.70	126.68	0.70	0.7	Yes	
5245	1" NPTF	1 1/4" NPTF (Female)	146	17.86	250.41	0.76	1.5	Yes	
5246	1 1/4" NPTF	1 1/4" NPTF (Female)	145	17.86	250.41	0.76	1.6	Yes	

Relief Valves - Stainless Steel									
Model	Connection Type		Dimensions (mm)		Flow Area (mm <sup>2</sup> )	K <sub>dr</sub>	Weight (kg)	ASME UV	CE/UKCA Cat
	Inlet	Outlet	A	ØB					
5340	1/2" NPTF	3/4" NPTF (Female)	94	9.53	71.26	0.67	0.4	Yes	Cat IV
5342	3/4" NPTF	3/4" NPTF (Female)	94	9.53	71.26	0.67	0.4	Yes	
5344A	3/4" NPTF	1" NPTF (Female)	105	12.70	126.68	0.70	0.6	Yes	
5344	1" NPTF	1" NPTF (Female)	105	12.70	126.68	0.70	0.6	Yes	
5345	1" NPTF	1 1/4" NPTF (Female)	146	17.86	250.41	0.76	1.3	Yes	
5346	1 1/4" NPTF	1 1/4" NPTF (Female)	145	17.86	250.41	0.76	1.4	Yes	

Valve Model / Setting Combinations										
Setting (barg)	526E	5230A	5231A	5231B	5232A	5240	5242	5244	5340	5342
10.3	N/A	N/A	N/A	N/A						
14.0										
16.2										
17.2										
20.7										
24.1										
24.8										
25.0										
25.9										
27.6										
29.3								N/A		
31.0								N/A		

Note: Blue indicates build to stock models