

Product Data Sheet

Product Datasheet

7E Carbon Monoxide CiTiceL[®]

Document Purpose

The purpose of this document is to present the performance specification of the 7E carbon monoxide sensor.

This document should be used in conjunction with Operating Principles (OP08) and the Product Safety Datasheet (PSDS 5).

The data provided in this document are valid at 20°C, 50% RH and 1013 mBar for 3 months from the date of sensor manufacture. For guidance on sensor performance outside of these limits, please refer to the Operating Principles OP08.

Output signal can drift below the lower limit over time. For guidance on the safe use of the sensor, please refer to the Operating Principles OP08.

Product Data Sheet

Key Features & Benefits:

- Robust, industry standard 7-Series packaging
- Compact Size

Technical Specifications

MEASUREMENT

Operating Principle	3-electrode electrochemical
Measurement Range	0-1000 ppm CO
Maximum Overload	2000 ppm CO
Filter	None
Sensitivity*	0.10 ± 0.02 µA/ppm
Response Time (T₉₀)*:	
7E	<25 Seconds at 20°C
7E/F	<30 Seconds at 20°C
Baseline Offset (clean air)*	-1 to +3 ppm equivalent
Zero Shift (-20°C to +40°C)	<9 ppm equivalent
Repeatability	1% of signal
Linearity	Linear

ELECTRICAL

Recommended Load Resistor	10 Ω
Bias Voltage	Not Required

MECHANICAL

Weight	17 g
Housing Material:	
Cap	Polycarbonate
Body	ABS
Orientation	Any

ENVIRONMENTAL

Typical Applications	Portable Life Safety
Operating Temperature Range	-20°C to +50°C
Recommended Storage Temp	0°C to 20°C
Operating Pressure Range	Atmospheric ± 10%
Pressure Coefficient	0.020 ± 0.008 % signal/mBar
Operating Humidity Range	15 - 90% RH non-condensing

LIFETIME

Long Term Sensitivity Drift	<5% signal loss/year
Expected Operating Life	Three years in air
Storage Life	6 months in CTL container

Product Dimensions

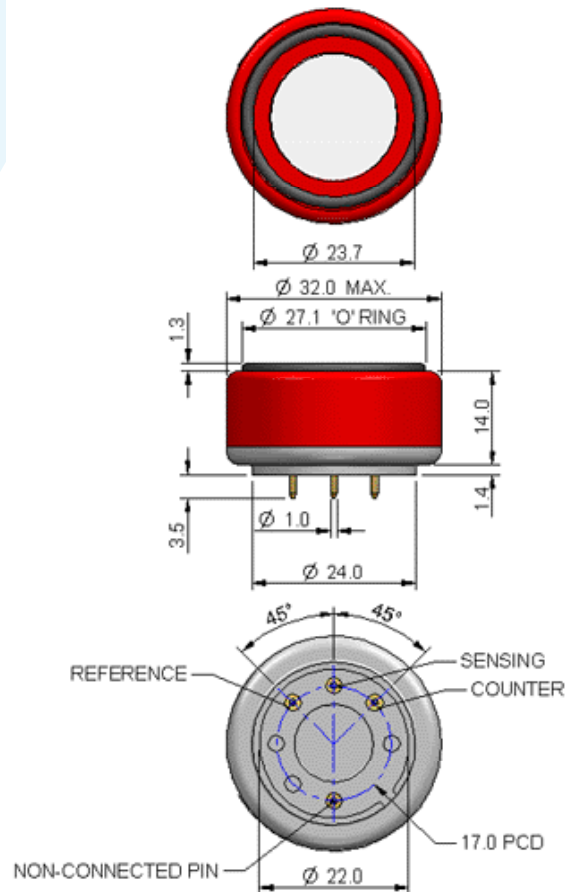

All dimensions in mm
All tolerances ±0.15 mm
unless otherwise stated

IMPORTANT NOTE:

Connection should be made via PCB sockets only. Soldering to the pins will seriously damage your sensor and invalidate the warranty.

* Specifications are valid at 20°C, 50% RH and 1013 mBar, using City Technology recommended circuitry. Performance characteristics outline the performance of sensors supplied within the first 3 months. Output signal can drift below the lower limit over time.

Product Data Sheet

Poisoning

CiTiceLs are designed for operation in a wide range of environments and harsh conditions. However, it is important that exposure to high concentrations of solvent vapours is avoided, both during storage, fitting into instruments and operation.

When using sensors with printed circuit boards (PCBs), degreasing agents should be used before the sensor is fitted. Do not glue directly on or near the CiTiceL as the solvent may cause crazing of the plastic.

Cross Sensitivity Table

Whilst CiTiceLs are designed to be highly specific to the gas they are intended to measure, they will still respond to some degree to various other gases. The table below is not exclusive and other gases not included in the table may still cause a sensor to react.

IMPORTANT NOTE : The cross sensitivity data shown below does not form part of the product specification and is supplied for guidance only. Values quoted are based on tests conducted on a small number of sensors and any batch may show significant variation. For the most accurate measurements, an instrument should be calibrated

Gas	Concentration Used	7E (ppm CO)
Hydrogen Sulfide, H ₂ S	15	38
Sulfur Dioxide, SO ₂	5	3
Nitric Oxide, NO	35	10
Nitrogen Dioxide, NO ₂	5	-3
Chlorine, Cl ₂	1	-0.5
Hydrogen, H ₂	100	<60
Hydrogen Cyanide, HCN	10	5
Hydrogen Chloride, HCl	5	0
Ethylene, C ₂ H ₄	100	<100

SAFETY NOTE

This sensor is designed to be used in safety critical applications. To ensure that the sensor and/or instrument in which it is used, are operating properly, it is a requirement that the function of the device is confirmed by exposure to target gas (bump check) before each use of the sensor and/or instrument. Failure to carry out such tests may jeopardize the safety of people and property.

Every effort has been made to ensure the accuracy of this document at the time of printing. In accordance with the company's policy of continued product improvement City Technology Limited reserves the right to make product changes without notice. The products are always subject to a programme of improvement and testing which may result in some changes in the characteristics quoted. As the products may be used by the client in circumstances beyond the knowledge and control of City Technology Limited, we cannot give any warranty as to the relevance of these particulars to an application. It is the clients' responsibility to carry out the necessary tests to determine the usefulness of the products and to ensure their safety of operation in a particular application.