

Characteristics / Ordering Code

Parker electronic modules PWDXXA-400 for rail mounting are compact, easy to install and provide time-saving wiring by disconnectable terminals. The digital design of the circuit results in good accuracy and optimal adaption for proportional directional control valves with position sensor by a comfortable interface program.

Features

The described electronic unit combines all necessary functions for the optimal operation of proportional directional control valves with position transducer or valves in closed loop systems. The most important features are:

- Digital circuit design
- Parameterizable position control of valve spool
- Constant current control
- Differential input stage with different signal options
- Monitor output for spool stroke
- Four-quadrant ramp function
- Enable input for solenoid driver
- Status indicator
- Parametering by serial USB interface
- Connection by disconnectable terminals
- In combination with valves without spool feedback
 - Pressure control with proportional pressure valve and pressure sensor
 - Position control with proportional DC valve and actuator position transducer
- Technology function "linearization"
- The PC software can be downloaded free of charge at www.parker.com/propxd.

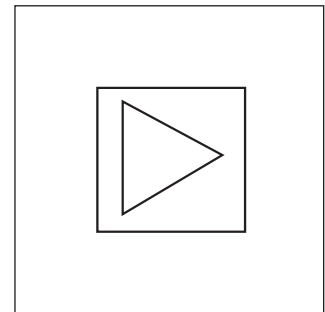
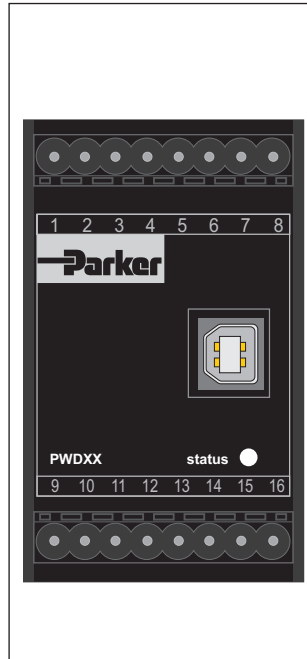

Ordering code

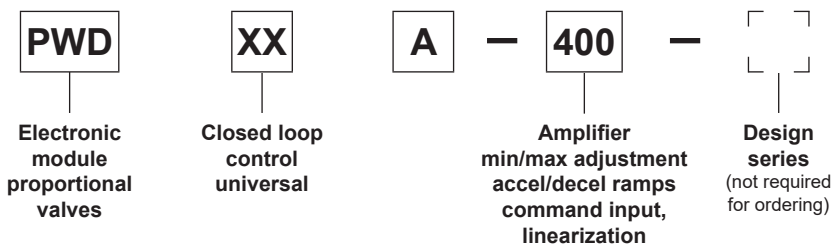

11

Technical data

General		
Model		Module package for snap-on mounting on EN 50022 rail
Package material		Polycarbonate
Inflammability class		V0 acc. UL 94
Installation position		unrestricted
Ambient temperature range	[°C]	-20...+60
Protection class		IP 20 acc. EN 60529
MTTF _D value	[years]	150
Weight	[g]	160
Electrical		
Duty ratio	[%]	100
Supply voltage	[VDC]	18...30, ripple < 5 % eff., surge free
Switch-on current typ.	[A]	22 for 0.2 ms
Current consumption max.	[A]	2.0
Pre-fusing	[A]	2.5, medium lag
Command signal options	[V] [mA] [mA]	+10...0...-10, ripple <0.01 % eff., surge free, Ri = 100 kOhm +20...0...-20, ripple <0.01 % eff., surge free, Ri = 200 Ohm 4...12...20, ripple <0.01 % eff., surge free, Ri = 200 Ohm <3.6 mA = solenoid output off, >3.8 mA = solenoid output on (acc. NAMUR NE43)
Input signal resolution	[%]	0.025
Differential input voltage max.	[V] [V]	30 for terminals 5 and 6 against PE (terminal 8) 11 for terminals 5 and 6 against 0V (terminal 2)
Sensor supply	[V]	18...30 (Us), max. current <100 mA
Enable signal	[V]	0...2.5: Off / 5...30: On / Ri = 100 kOhm
Status signal	[V]	0...0.5: Off / Us: On / rated max. 15 mA
Monitor signal	[V]	+10...0...-10, rated max. 5 mA, signal resolution 0.4 %
Adjustment ranges	Min [%] Max [%] Ramp [s] Zero offset [%] Current [A] Initial current [%]	0...50 50...100 0...32.5 +100...-100 1.3 / 2.7 / 3.5 0...25
Interface		USB type B
EMC		EN IEC 61000-6-2, EN IEC 61000-6-4
Connection		Screw terminals 0.2...2.5 mm ² , disconnectable
Cable specification	[mm ²] [mm ²]	1.5 overall braid shield for supply voltage and solenoids (AWG16) 0.5 overall braid shield for sensor and signal (AWG20)
Cable length	[m]	50
Technology function		Software adjustable transfer function with 10 compensation points for linearization of valve behaviour

Block diagram

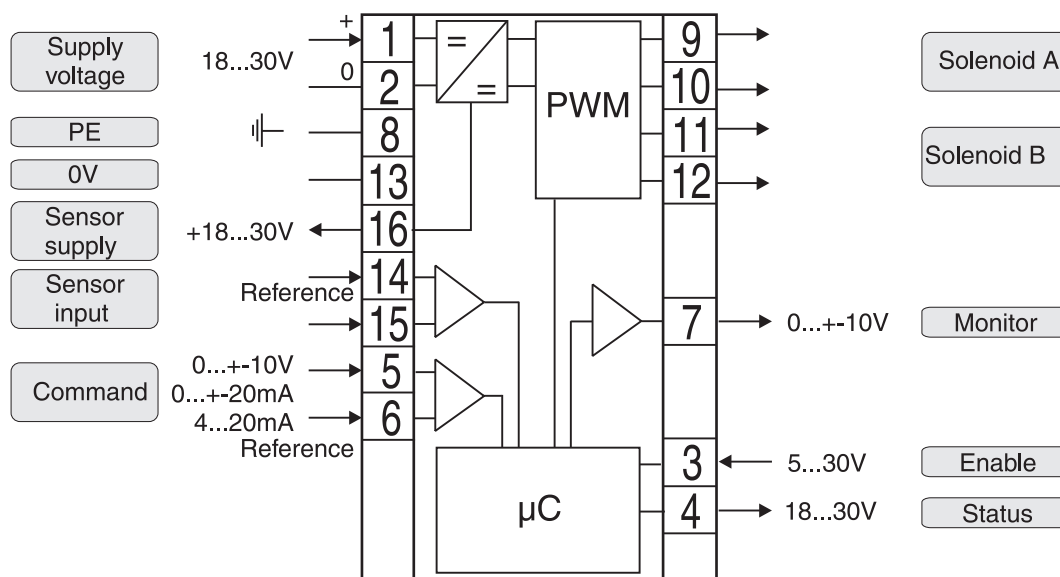

Signal flow diagram

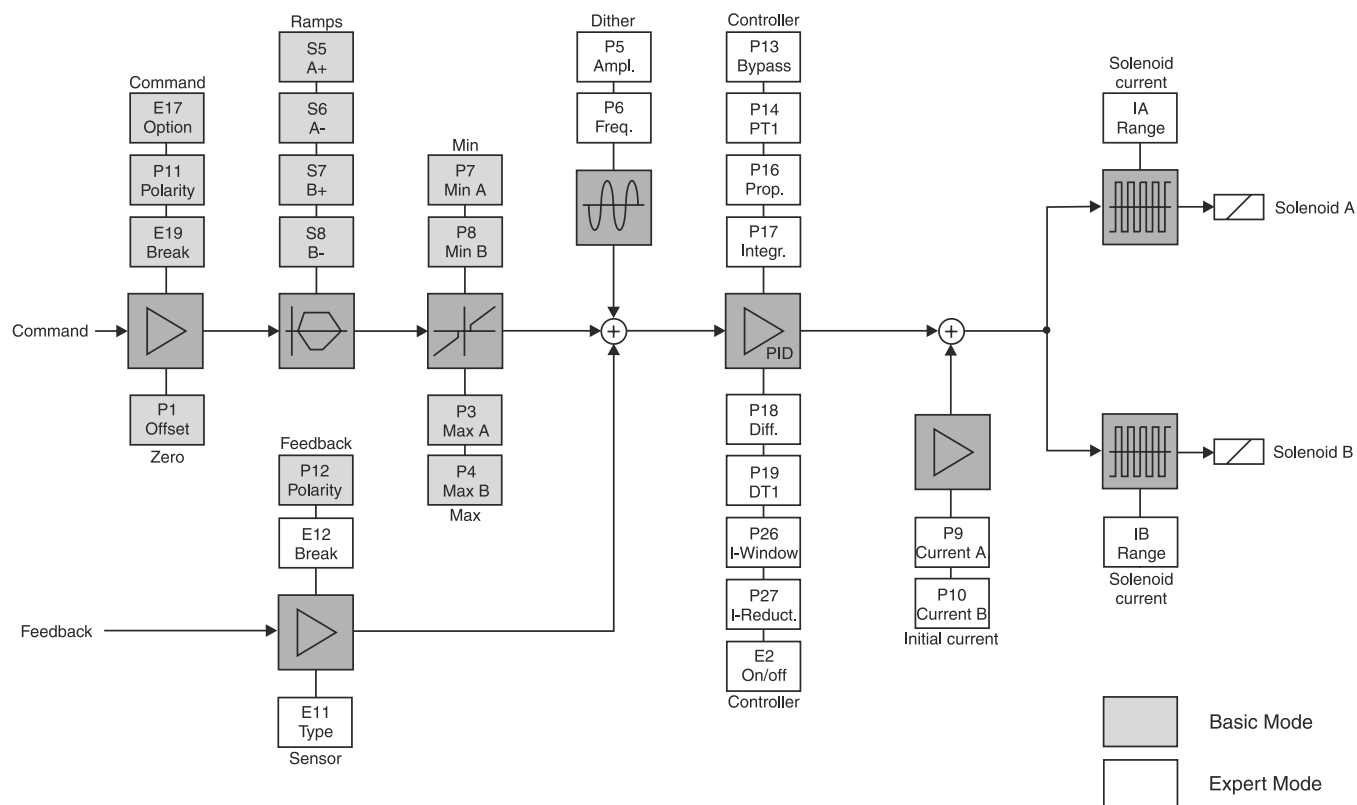

Dimensions

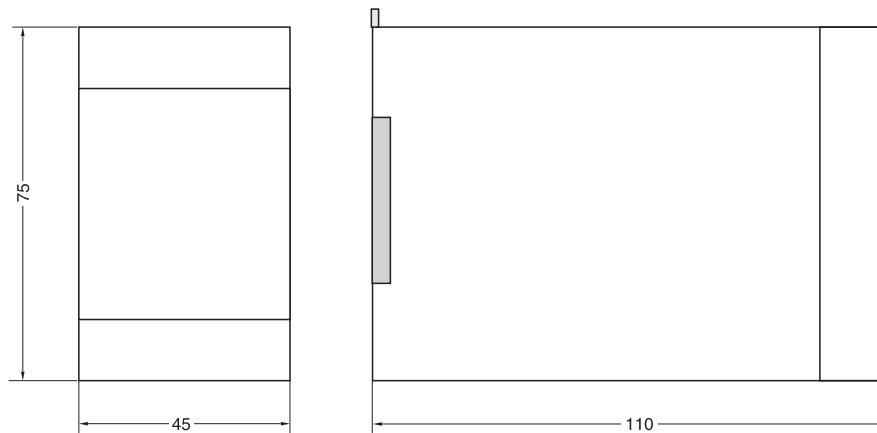

ProPxD interface program

The ProPxD software permits comfortable parameter setting for the module electronics. Via the clearly arranged entry mask the parameters can be monitored and modified. Storage of complete parameter sets is possible as well as printout or record as a text file for further documentation. Stored parameter sets may be loaded anytime and transmitted to other valves. Inside the electronics a nonvolatile memory stores the data with the option for recalling or modification.

The PC software can be downloaded free of charge at www.parker.com/propxd.

Features

- Comfortable editing of all parameters
- Depiction and documentation of parameter sets
- Storage and loading of optimized parameter adjustments
- Executable with all actual Windows® operating systems from Windows® XP upwards
- Plain communication between PC and electronics via USB interface

The screenshot displays the Parker ProPxD software interface. On the left, the 'Device Type' section shows 'Device PWDXXx-40x' and 'Device Firmware 2.2'. Below this is the 'Device Center' with a list of parameters including PID, FEEDBACK INPUT, COMMAND INPUT, MIN / MAX, SENSOR SUPPLY OUT, CURRENT SOLENOID-A, CURRENT SOLENOID-B, OFFSET, DITHER, FEEDBACK SCALING, MONITOR OUT, RAMPs, and DEVICE INFORMATION. The 'Valve Selection' section shows 'Type D1FB****K3' and 'D1FB****K3'. The 'Status Center' shows 'Parameter State SYNCHRONIZED', 'Connection State ONLINE', 'Device State ENABLED', and 'Fault State NO ERROR'. The main 'Device Model' section contains a block diagram of the control system, including blocks for COMMAND INPUT, FEEDBACK INPUT, OFFSET, RAMPs, MIN / MAX, LINEARIZATION, DITHER, PID, INITIAL CURRENT, CURRENT SOLENOID-A, CURRENT SOLENOID-B, MONITOR OUT, and SENSOR SUPPLY OUT. On the right, the 'Input Configuration' section shows 'COMMAND INPUT' (Signal Type ±10V) and 'FEEDBACK INPUT' (Sensor Type ±10V). The 'Output Configuration' section shows 'CURRENT SOLENOID-A' and 'CURRENT SOLENOID-B' (Current Range (max.) 2700mA), 'SENSOR SUPPLY OUT' (Function Sensor Supply), and 'MONITOR OUT' (Function Feedback Output). The bottom status bar includes '© PARKER HANNIFIN Manufacturing Germany GmbH & Co. KG - ISDE - 2023 | Program Version 2.0.3.0' and 'Operator Maintenance Proprietary'.