

VFZ 210

High-Performance Two-Way Electric Valves and Actuators

Product Description

VFZ Butterfly series valves and electric actuators are mainly used for mainline HVAC system control and building drainage. These high-performance two-way Butterfly electric valves and actuators provide system opening and closing in applications where proportional control is required.

Applications include:

- Chilled water, cooling water system
- Boilers, plate heat exchanger water system
- Ice storage for air-conditioning system

VFZ 210 Valve Features

- Valve sizes from DN50 to DN500.
- Polyester coated body and anti-corrosion for harsh environments
- Seat is molded in the valve body for complete dielectric isolation.
- Wafer design does not require special valve mounting flanges.
- The valve disc provides long life, low operating torque, zero leakage with bidirectional bubble seal.
- Two valve stem seals ensure the fluid medium is completely isolated from the stem to prevent leakage.



MFZ Actuators



VFZ 210W

MFZ Actuator Features

- Small and light weight with large output torque.
- The valve can be manually operated with and without power to the actuator.
- Suitable for harsh environments: epoxy coating prevents corrosion, abrasion, impact and UV damage.
- Highly visible individual terminals enable easy wiring.
- Electronic and mechanical stroke limit: two SPDT switches control fully open and fully closed. On power failure mechanical travel effectively limits the stroke of the actuator.
- Motor thermal protection: the motor is equipped with thermal overload.
- Internal PTC heater ensures temperature is stable and non-condensing.

Life Is On

Schneider
Electric

VFZ 210W Valve Specifications

Design	Linear Butterfly
Medium	Cold water, hot water, up to a 50% solution of ethylene glycol
Medium temperature	-20...120°
Leakage class	Bi-directional zero leakage tight seal(gas test)
Rated pressure class (DN50 ... 500)	PN16
Connection	Wafer flange ISO 7005.2
Maximum Closing Pressure	1200 kPa
Installation location	Vertical or Horizontal
Rotation angle	90°
Construction Materials	
Body	Ductile iron (GGG40)
Valve Seat Plate	Stainless steel (SS304)
Seat	EPDM
Stem	stainless steel (SS304)

Actuator Time-Out Feature

Non-Spring Return actuators with time-out will automatically limit the running time of the actuator. The time-out feature automatically cuts off the control signal to the valve after three minutes of continuous operation. Upon change in control signal direction, the actuator resumes operation.

NOTE:

- Multiple actuators may be connected to a single controller.
- Do not exceed the maximum current draw of the controller.
- Use of a properly sized, inherently limited, Class 2 transformer is recommended.
- Use only 18...24 AWG copper wire for all connectors. When using multiple wires under one terminal do not exceed 2 wires or 20 AWG wire.

Operation Modes

VFZ 210W Series Butterfly Valves are driven by the MFZ series actuator. Select an actuator in accordance with a desired close-off pressure and control type, either modulating or on/off control. The valve disc is driven to desired position based upon the input control signal to the actuator.

Manual Operation

In case of power loss the valve can be manually operated by a hand wheel or wrench.

Maintenance

The valve and actuator assembly itself requires no maintenance. Regular maintenance of the total HVAC system is recommended to ensure sustained optimum performance.

Field Repair

Valves and actuators are not field repairable. Replace entire unit as necessary.

Agency Listings & Related Standards

- ISO 10631: General Metal valve
- API609: Butterfly: double flange, and a single clip-on JIS
- B2032: Wafer rubber valve seat ASME
- B16.34: Valves - flanges, threaded and welded end
- ISO 5208: industrial valves - Valve Pressure Test

Wiring

Make sure all connections are according to the job wiring diagrams and in compliance with local and national electrical codes. Refer to diagrams shown for typical wiring.

Valve/Actuator Assembly Part Numbers with Kvs(m³/h) disc position

Size	On/Off	Modulating	Valve disc position (angle)								
			90°	80°	70°	60°	50°	40°	30°	20°	10°
DN50	VFZ210W-050-080T	VFZ210W-050-080M	80	75	57	39	27	21	16	6.9	1.09
DN65	VFZ210W-065-080T	VFZ210W-065-080M	170	142	99	64	42	30	19	7.5	5.2
DN80	VFZ210W-080-080T	VFZ210W-080-080M	290	278	205	139	87	51	34	21	7.7
DN100	VFZ210W-100-100T	VFZ210W-100-100M	560	404	270	137	105	67	46	26	6.3
DN125	VFZ210W-125-125T	VFZ210W-125-125M	870	744	502	306	186	113	60	33	15.6
DN150	VFZ210W-150-125T	VFZ210W-150-125M	1340	1185	720	472	294	171	94	47	25.9
DN200	VFZ210W-200-200T	VFZ210W-200-200M	2690	2360	1483	956	617	362	211	88	52
DN250	VFZ210W-250-300T	VFZ210W-250-300M	5540	3948	2364	1502	911	588	334	193	84.5
DN300	VFZ210W-300-300T	VFZ210W-300-300M	7540	6147	3607	2083	1229	706	401	164	4.13
DN350	VFZ210W-350-350T	VFZ210W-350-350M	10300	9348	6233	3938	2380	1335	606	291	5.2
DN400	VFZ210W-400-400T	VFZ210W-400-400M	14300	12856	8571	5416	3237	1836	847	400	6.9
DN450	VFZ210W-450-450T	VFZ210W-450-450M	18900	17028	11352	7172	4334	2433	1122	530	9.5
DN500	VFZ210W-500-500T	VFZ210W-500-500M	24200	21893	14596	9222	5573	3128	1443	683	12

All sizes maximum closing pressure: 1200 kPa

MFZ Actuator Specifications

Torque	50...2000 Nm
Input Power	220 VAC 50Hz
Limit switch	SPDT x2
Closed position feedback	Dry contact (220V 10A ½ hp)
Heater	Standard
Torque switch	Optional
Overheat protection temp	135 °C
Operating temperature	-30...60 °C (continuous operation @ maximum ambient temperature 40°)
Timing (full open to full closed)	~ 30 seconds (DN50...DN400) ~ 60 seconds (DN450...DN500)
Enclosure Rating	IP67-IP68
Cable Connector	G1 / 2 Waterproof
Mounting orientation	Installed at any angle
Material	ASTM B85 Pressure die-cast aluminum, anti-corrosion coating
Control signal, Feedback signal	0...10V or 4...20mA



Operation Notes

Electrical Connections

Open the cover to access power and signal wires respectively with the terminal block.

Manual Operation

Turn the handwheel clockwise for closing and counter-clockwise for opening. With power connected, the actuator will return to the signal specified position. With power disconnected, the valve will stay in manual position until either manually moved or power is reapplied.

Overload Protection

The actuator has overload protection: when the running torque exceeds the rated value the overload protection engages to prevent motor overload.

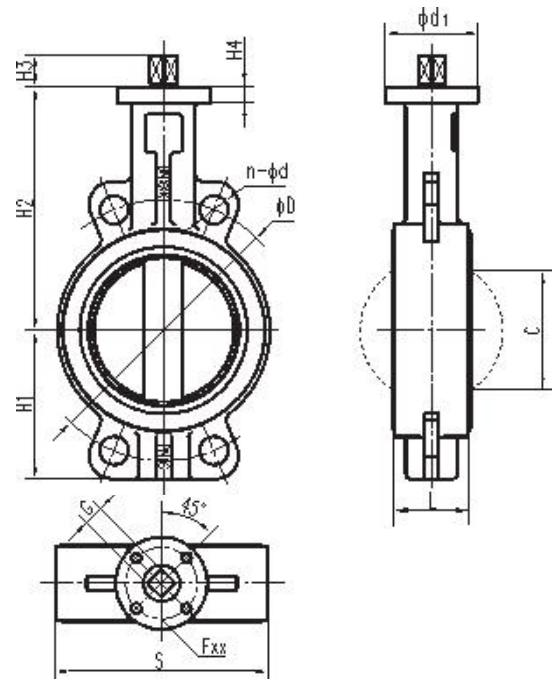

VFZ 210W Valve Dimensions (mm)

Part Number/Size		L	C	S	H1	H2	H3	H4	G	Ød1	ØD	n-Ød	kg
VFZ210W-050 DN50	F05	43	33	118	65	130	13	9	14	65	125	4-18	2.0
VFZ210W-065 DN65	F05	46	48	135	71	143	13	9	14	65	145	4-18	2.4
VFZ210W-080 DN80	F05	46	66	149	92	155	13	9	14	65	160	8-18	2.7
VFZ210W-100 DN100	F05	52	91	150	104	170	13	11	14	65	180	8-18	4.1
VFZ210W-125 DN125	F07	56	115	176	118	190	19	13	17	90	210	8-18	6.2
VFZ210W-150 DN150	F07	56	142	204	132	210	19	13	17	90	240	8-22	7.6
VFZ210W-200 DN200	F07	60	194	260	167	243	19	15	17	125	295	12-22	12.0
VFZ210W-250 DN250	F10	68	245	316	198	282	21	17	22	125	355	12-26	19.7
VFZ210W-300 DN300	F10	78	294	372	231	310	24	17	22	125	410	12-26	31.0
VFZ210W-350 DN350	F10	78	328	422	256	345	24	20	22	125	470	16-26	41.1
VFZ210W-400 DN400	F14	102	374	473	294	377	38	21	36	175	525	16-30	65.9
VFZ210W-450 DN450	F14	114	425	425	337	422	38	21	36	175	585	20-30	82.2
VFZ210W-500 DN500	F14	127	472	472	375	466	38	22	36	210	650	20-33	104.4

Valve Part Numbering

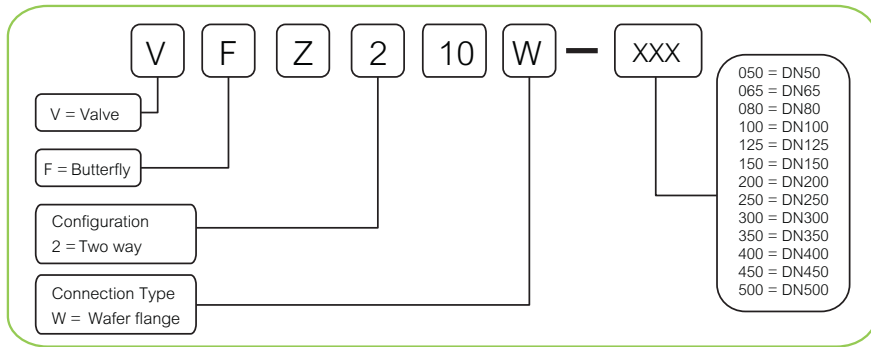

MFZ Actuator Dimensions (mm)

MFZ 080T (M)

100T (M)

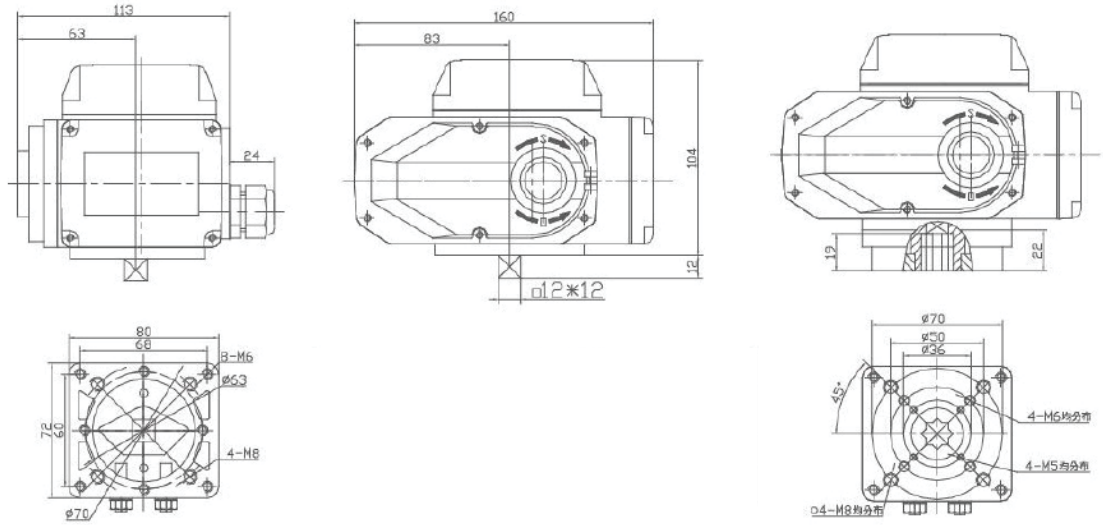

MFZ125T (M)

150T (M)

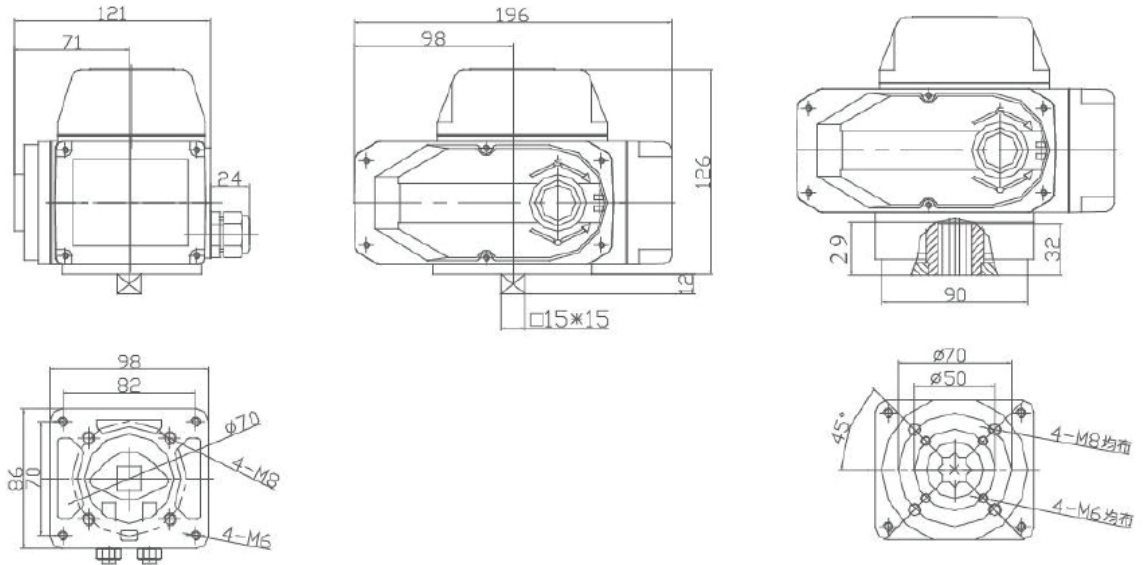

MFZ 200T (M)

300T (M)

350T (M)

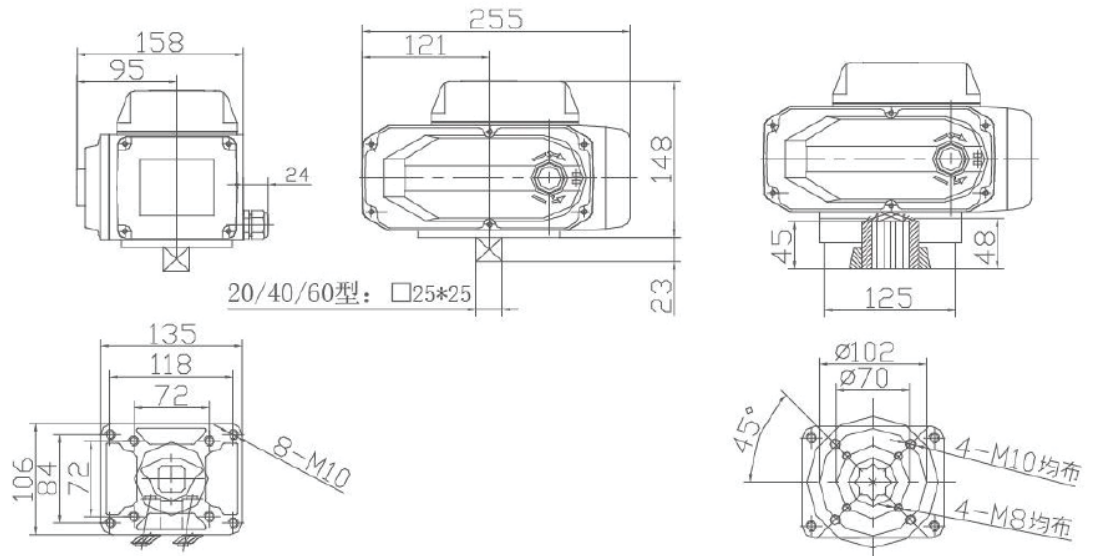

MFZ-400T (M), MFZ-450T (M), MFZ-500T (M)

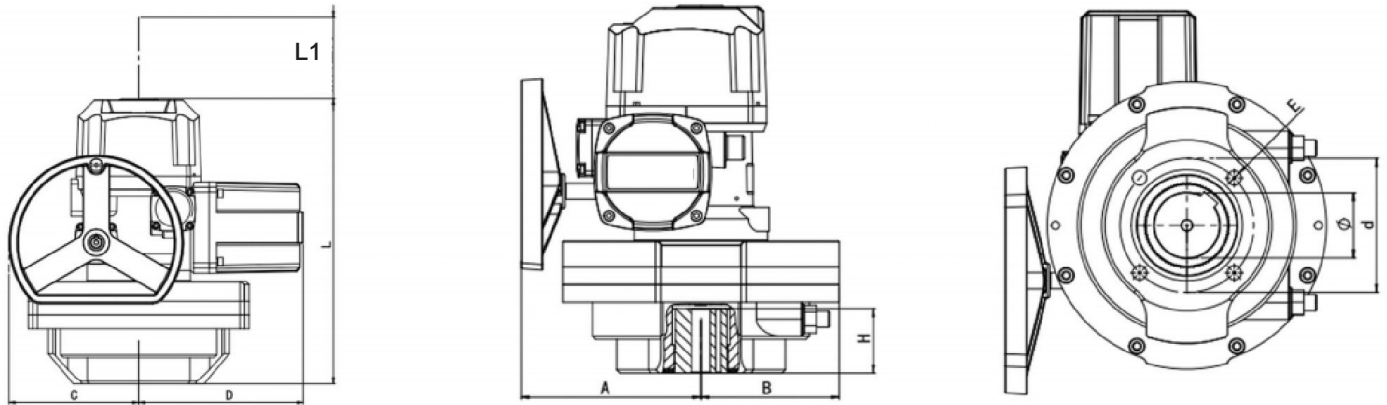

Model	A	B	C	D	L	d	E	H	Q _{Min}	Q _{Max}	Reserve space L1
MFZ-400T (M)	219	114	168	264	331	125	4-M12	55	21	36 / 32	130
MFZ-450T (M)	224	132	208	264	417	140	4-M16	65	26	40 / 50	130
MFZ-500T (M)	224	132	208	264	417	140	4-M16	65	26	40 / 50	130

Actuator Part Numbering

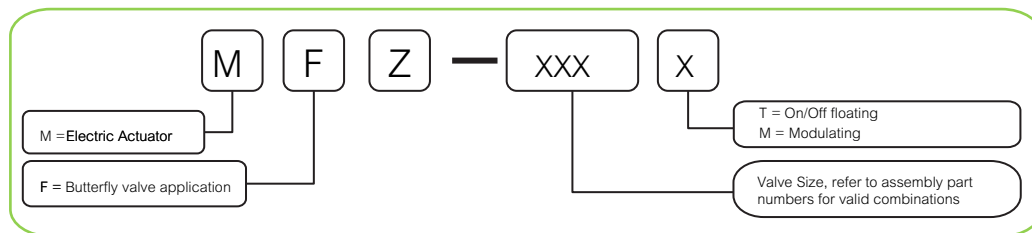

MFZ Series Actuator Wiring

Note: this figure is for reference only. If an actual wiring diagram is required, refer to the illustration in the actuator cover or the relevant technical parameter table.

MFZ-80T...MFZ-350T

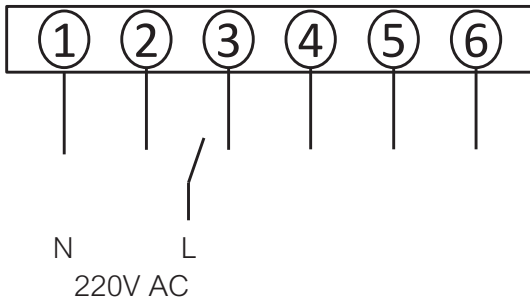

Terminal No.	Function
1	Line
2	Actuator Open
3	Actuator Close
4	Switch COM
5	Switch Full Open Contact
6	Switch Full Closed Contact

Note: Incorrect wiring will damage the actuator. Please make sure power is off before wiring the actuator.

MFZ-400T

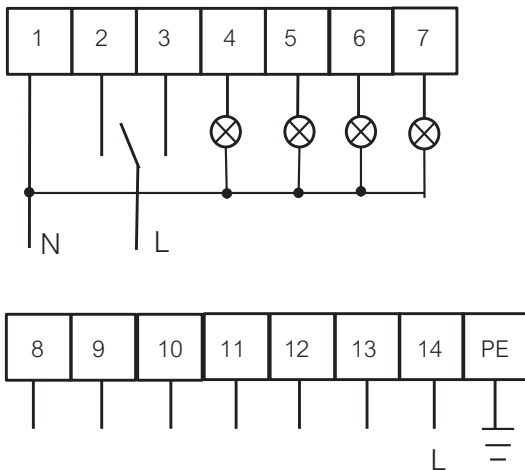

Terminal No.	Function
1	Neutral
2	Actuator Open
3	Actuator Close
4	Full Open Indication
5	Full Closed Indication
6	Open Over Torque Indication
7	Close Over Torque Indication
8	Open Switch COM
9	Open Switch NO Contact
10	Open Switch NC Contact
11	Closed Switch NO Contact
12	Closed Switch NC Contact
13	Closed Switch COM
14	PTC Heater
15 PE	Ground

Note: Incorrect wiring will damage the actuator. Please make sure power is off before wiring the actuator.

MFZ-450T

MFZ-500T

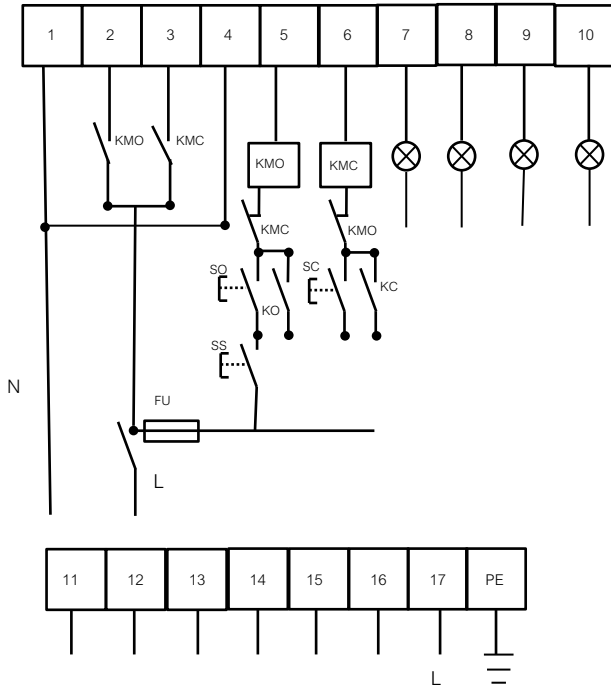

Terminal No.	Function
1	Neutral
2	Actuator Open
3	Actuator Close
4	Neutral
5	SS: Stop button SO: Open valve button
6	SS: Stop button SC: Close valve button
7	Full Open Indication
8	Full Closed Indication
9	Open Over Torque Indication
10	Close Over Torque Indication
11	Open Switch COM
12	Open Switch NO Contact
13	Open Switch NC Contact
14	Closed Switch COM
15	Closed Switch NO Contact
16	Closed Switch NC Contact
17	PTC Heater
18 PE	Ground

MFZ-080M...MFZ-350M

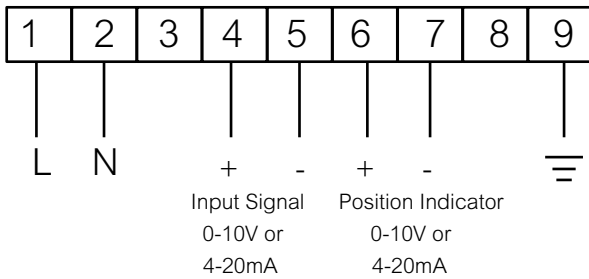

Terminal No.	Function
1	Line
2	Neutral
3	Input Signal +
4	Input Signal -
5	Feedback Output Signal +
6	Feedback Output Signal -

Note: Incorrect wiring will damage the actuator. Please make sure power is off before wiring the actuator.

MFZ-400M, MFZ-450M, MFZ-500M

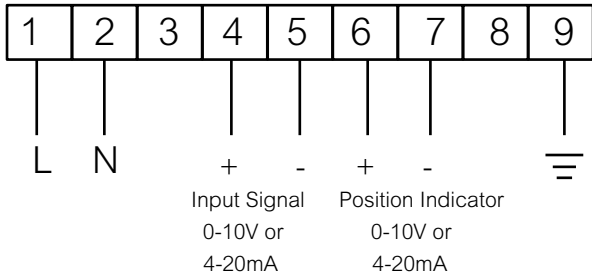

Terminal No.	Function
1	Line
2	Neutral
3	
4	Input signal +
5	Input signal -
6	Position Indicator +
7	Position Indicator -
8	
9	Ground

VFZ 210W Assembly Dimensions (mm)
DN50-DN350

DN	H1	H2	H3	L	G	L1	D1	4-0D
DN50	70	130	107	161	142	42.6	0125	4-018
DN65	76	143				45.6	0145	
DN80	89	155				51.6	0180	
DN100	104	170	130	198	150	55.6	0210	4-022
DN125	120	190				0240		
DN150	132	210	150	256	184	59.6	0295	4-026
DN200	167	243				67.6	0410	
DN250	202	282				77.6	0470	
DN300	239	310				77.6	0470	
DN350	265	345						

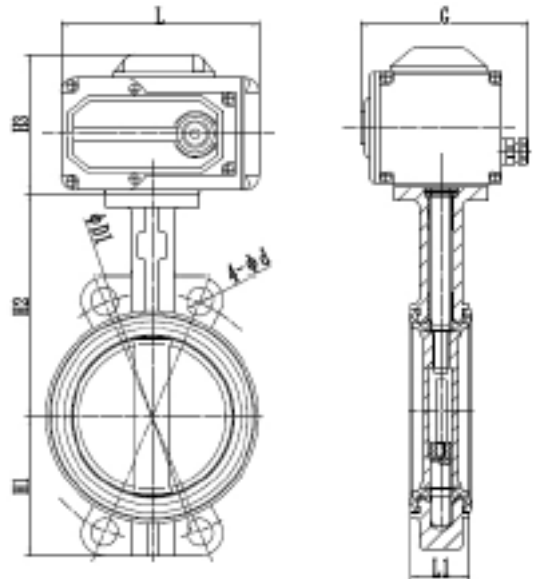

VFZ 210W Assembly Dimensions (mm)
DN400-DN500

DN	H1	H2	H3	A	B	L	L1	D1	4-0D
DN400	310	401	310	193	107	433	102	0525	4-030
DN450	343	412	417	224	132	472	114	0585	
DN500	379	440					127	0650	4-033

