

Pumps for heat transfer technology

*Centrifugal pumps
with uncooled mechanical seal or magnetic coupling*

Regenerative turbine pumps with magnetic coupling

Research and development with recent test stands



Computer-controlled and fully automated test stands on the premises of Speck in Roth. Measuring of hydraulics, power requirements, axial thrust, vibrations and NPSH values. Heads of up to 400 m and flow rates of up to 750 m³/h are possible.



Thermal oil test stand with pump surveillance system on the premises of Speck in Roth. Research of impacts of high temperatures up to 350 °C on the lifetime of the pumps.

International representatives

→ page 12

Pumps for heat transfer technology

Centrifugal pumps

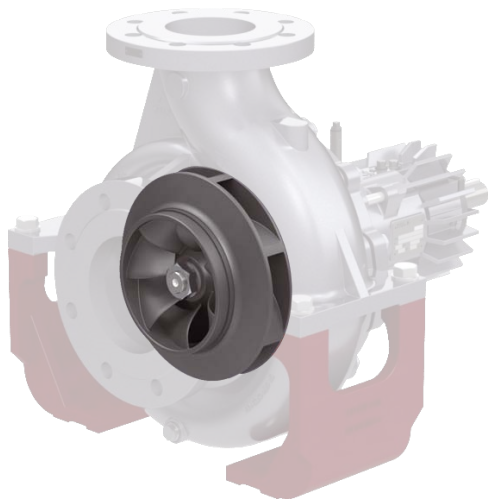

Series TOE-G and TOE-M

Consistent design modular system with volute casings

Choose from six different designs with mechanical seal or magnetic coupling.

Developed for circulating organic or synthetic heat transfer oils in heat transfer systems in accordance with DIN 4754, as well as hot water.

Suitable for pumped media with low amounts of non-abrasive impurities.

Heat transfer media	-100 °C to 350 °C, up to 400 °C on request
Hot water	up to 160 °C, up to 180 °C on request
Nominal pressure	PN 16
$H_{\max.}$ (2900 min ⁻¹)	100 m
$Q_{\max.}$ (2900 min ⁻¹)	550 m ³ /h
Casing	Spheroidal graphite iron/ stainless steel

Regenerative turbine pumps

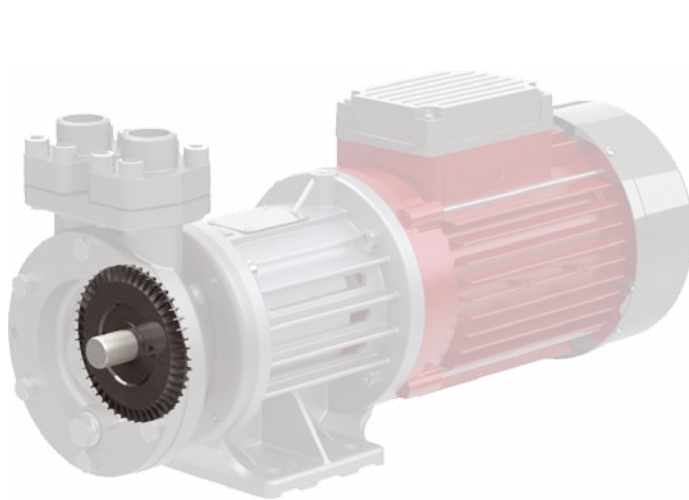

Series NPY-MK and CY-MK

Tried and tested and compact close-coupled pumps with top/top casings and magnetic coupling

Developed for transporting and circulating organic or synthetic heat transfer oils and hot water.

Suitable for pumped media with low quantities of non-abrasive impurities.

Heat transfer media	up to 350 °C
Hot water	up to 220 °C
Nominal pressure	up to PN 24
$H_{\max.}$ (2900 min ⁻¹)	90 m
$Q_{\max.}$ (2900 min ⁻¹)	12 m ³ /h (200 l/min), 24 m ³ /h (400 l/min) on request
Casing	Stainless steel / spheroidal graphite iron

Main applications

- » Tempering in plastics and die casting industry
- » Baking ovens, large frying units as well as in the production of edible oil and dry masses for the food and feedstuff industries
- » Heating calenders and melting containers in the leather and rubber industry
- » Heating stirring and mixing vessels in the production of paints and varnishes
- » Heating tank storage facilities on stationary and FPSE platforms, as well as in tankers
- » Heating press lines in the wood and pulp industry
- » Flat glass production
- » Solar power plants and ORC processes

Find the right pump for your system

Choose the best solution from six ranges

Each heat transfer system is unique in its own way - on some, the sealing principle is key, on others the vertical installation frame or perhaps the special properties of the medium.

With the heat transfer pumps from Speck you can choose from six ranges with different characteristics and find the best solution for your system.

Series TOE-G with mechanical sealing

Hot water versions

- » Water up to 160 °C
- » Water up to 180 °C on request

Thermal oil versions

- » Heat transfer media: -40 °C up to 350 °C

In comparison to pumps with magnetic coupling:

- » More favourable in purchase and repair
- » Less energy consumption with the same operating point

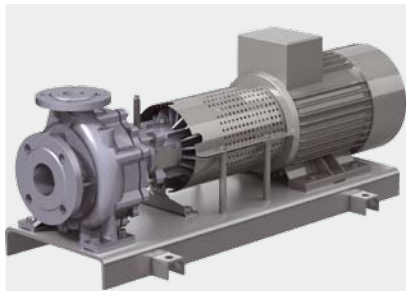

← TOE-GN | TOE-MN →

Bearing bracket / process design
Base plate

Dismantling of the bearing bracket possible
without moving the motor

Alignment / checking of the coupling
required before start-up



← TOE-GA | TOE-MA →

Bracket version

No alignment of the coupling required
before start-up

Space for disassembling the cartridge insert
required

Base plate optional



← TOE-GI | TOE-MI →

Bracket version

No alignment of the coupling required
before start-up

Space for disassembling the cartridge insert
required

Series TOE-M with magnetic coupling

Spheroidal graphite cast iron versions

- » Heat transfer media: -40 °C up to +350 °C, up to 400 °C on request

Stainless steel versions

- » TOE-MN/MA in sizes 32-160, 32-200, 40-200, 50-200 and 65-200 only
- » Heat transfer media: -100 °C up to +250 °C

In comparison to pumps with mechanical sealing:

- » Longer lifetime
- » No leakage and odour nuisance
- » ATEX

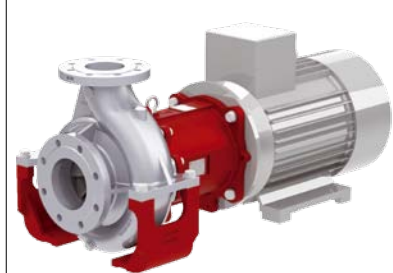
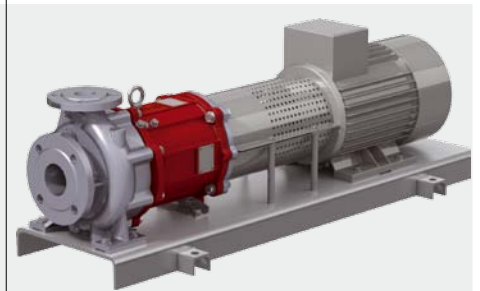

Minimal spare parts stock and flexibility thanks to the modular system

Thanks to the modular system with consistent design, many components are identical and interchangeable across the six ranges. This means minimal spare parts stock.

And it also guarantees complete flexibility, as replacing pumps and components or retrofitting to a different design is easy.

Series TOE-G with mechanical sealing

- ① Only two bearing brackets for all frame sizes
 - » Bearing bracket 360 for 12 frame sizes identical and interchangeable
 - » Bearing bracket 470 for 7 frame sizes identical and interchangeable
- ② Only one bracket per bearing bracket

Interchangeable casings

Series TOE-M with magnetic coupling

- ③ Only two bearing brackets and two brackets for all frame sizes
 - » Bearing bracket 360 identical for 12 frame sizes
 - » Bearing bracket 470 identical for 7 frame sizes
 - » Interchangeability of the whole bearing bracket is given if the magnetic coupling is the same

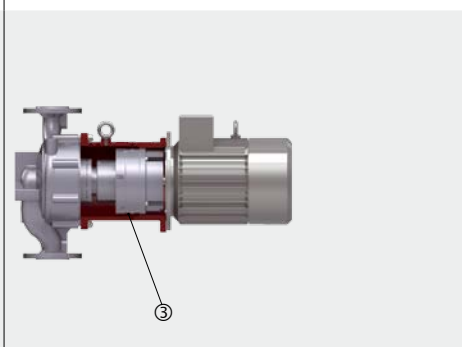
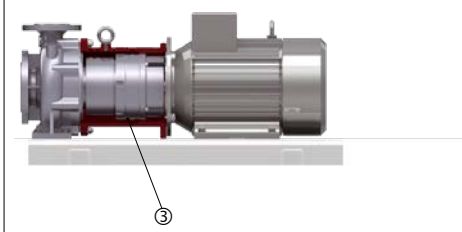
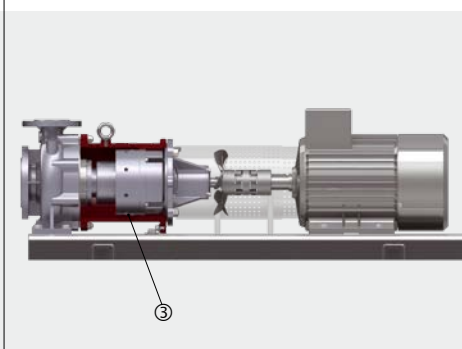
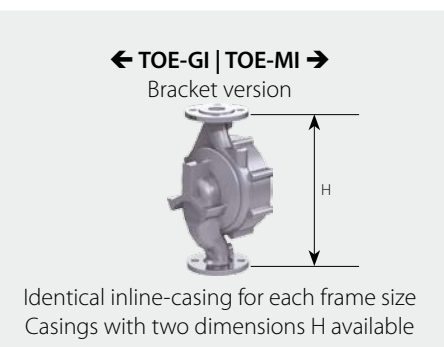
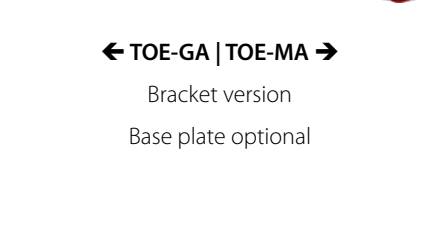
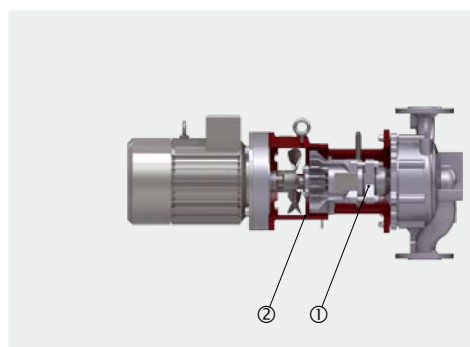
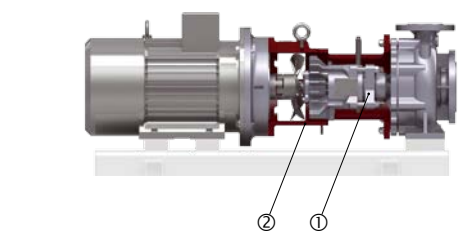
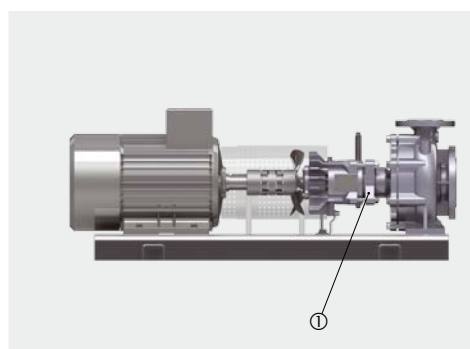

High operational safety, optimal design and service-friendly

Robust design

Torsion-resistant casing cover

Ball bearings with lifetime lubrication

Wear-resistant SiC sleeve bearings

Solid, hydrodynamically lubricated sleeve bearings made from SiC as tried-and-tested slide material - extremely wear-resistant and good resistance in corrosive media.

Impellers with back vanes

The back vanes of the impellers significantly reduce the axial thrust and therefore remove strain from the mechanical seal and the ball bearings considerably. They also keep dirt particles away from the sleeve bearings.

Magnetic couplings

Supplied with radial start-up safety device as standard at Speck.

Optimised for synthetic heat transfer oils

Dry-run safety function for the mechanical seal

Synthetic heat transfer oils are being used more and more frequently due to the benefits they offer. However, low-boilers develop in the synthetic oils over time in form of gas bubbles, can lead to dry-running on the mechanical seal.

This is ruled out completely in the generously designed mechanical seal casings from Speck. An anti-vortex rib reliably prevents gas bubbles from forming on the mechanical seal.

The vacuum generated by the back vanes also ensures that the low-boilers do not collect in the mechanical seal casing and are returned to the media circuit.

Clever temperature management

Optimised cooling of ball bearings, mechanical seal and sleeve bearings

The air flow generated by the fan blade on the coupling cools the mechanical seal and the ball bearing optimally in combination with coupling protection or bracket and several cooling fins. The additional cooling zone reduces the temperature on the sleeve bearings.

Optimised cooling of the ball bearings and magnetic coupling

A fan blade is also used for cooling in the TOE-MN series. Here, the generated air flow, in combination with coupling protection, ventilation slots and cooling zone, reduces the temperature on the magnetic coupling and ball bearings extremely effectively.

On close-coupled pumps, the air flow from the motor fan also cools the bearing shield and therefore also the ball bearings inside it.

Pumps with mechanical seal

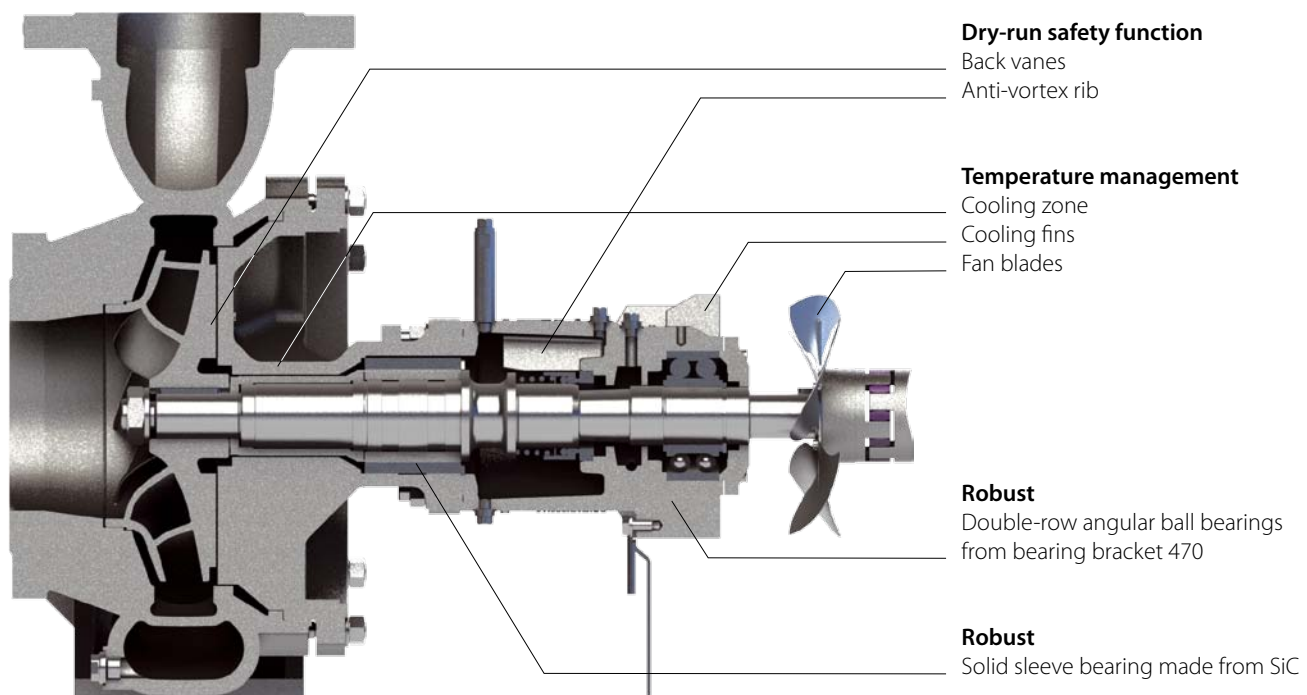

Fig.: TOE-GN, bearing bracket 470, casing with centreline mounting

Also suitable for critical applications

Mechanical seal with quench

For media, which are prone to crack product formation on the sealing surfaces of the mechanical seal, versions with quench are available.

Pumps with magnetic couplings

100% free of leakage and with lower maintenance requirements than pumps with mechanical seal.

ATEX

All magnetically-coupled pumps are ATEX-certified.

Optimal design

Energy efficiency

High energy efficiency secures a lasting competitive edge.

Speck offers the important criteria for energy-optimised design: Seamless range of sizes, highly efficient impellers, switching of impellers for the best design at the operating point and, naturally, motors in accordance with IE3.

Optimal sizes of the magnetic couplings

Magnetic couplings in staged sizes guarantee optimal design at the operating point with minimal viscosity and eddy current losses.

Maintenance-friendly and flexible

Simple installation

All six series are extremely maintenance-friendly thanks to easy-to-remove bearing brackets.

For pumps with magnetic coupling, you can also replace the sleeve bearing cartridge easily as a complete spare part. It is quick and ensures correct installation every time.

Minimum spare parts stock

The high level of interchangeability of identical parts guarantees minimal spare parts stock requirements and an extremely high level of flexibility.

The bearing bracket 360 alone is used with mechanical seal in all three series in up to twelve sizes.

Retrofitting to a different series is also no problem at all - the volute casing can even be left in the system.

Pumps with magnetic coupling

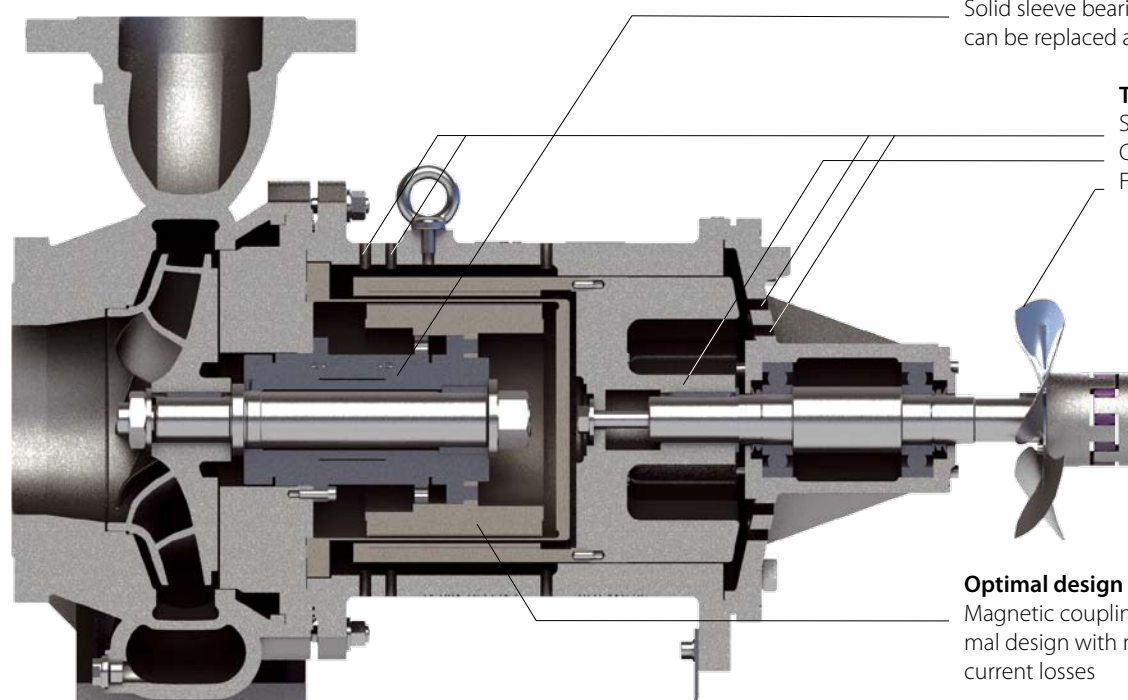

Robust and maintenance-friendly

Solid sleeve bearing cartridge with SiC - can be replaced as a complete spare part

Temperature management

Several ventilation slots
Cooling zone
Fan blades (TOE-MN only)

Optimal design

Magnetic couplings in staged sizes for optimal design with minimal viscosity and eddy current losses

Fig.: TOE-MN, bearing bracket 470, casing with centreline mounting

Longer lifetime

There are effects, which have little or no relevant impact on smaller designs, but lead to increased wear in larger pumps.

Speck offers larger pumps with special designs to guarantee a longer lifetime: Casing with centreline mounting and double volute.

Centreline mounting relieves strain from the bearings and coupling

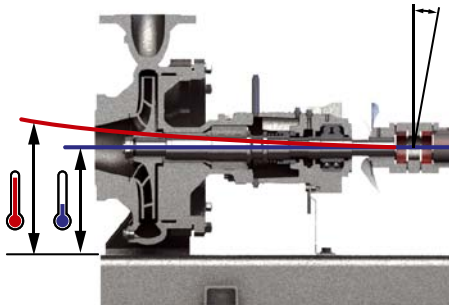

Casing with feet: The larger the pump, the more strain placed on the bearings and coupling by heat expansion

Casings with feet can only expand upwards in high temperatures, which causes the shaft to tilt and bend. This has an impact on the sleeve bearings and shaft coupling in particular. As the heat expansion increases with larger casing size, the sleeve bearings and couplings also wear faster on larger pumps.

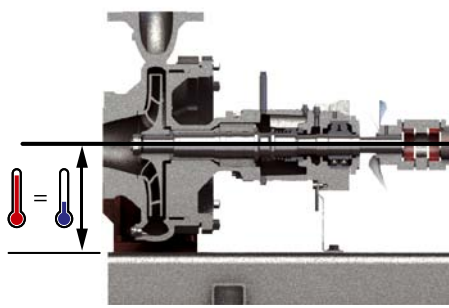

The centreline mounting eliminates the impact of the heat expansion completely.

Speck is the only manufacturer to use a centreline mounting for heat transfer pump volute casings, PN 16. It eliminates the impact of vertical expansion completely. The shaft is also always aligned at the optimal height, even in hot operation, and bearings and coupling achieve a significantly higher lifetime.

A double volute remove strain from the sleeve bearings

Radial forces are applied directly on the sleeve bearings. The forces increase with higher impeller diameters and higher speeds. This is why the sleeve bearings on larger pumps with single volute casings wear faster.

Speck therefore uses casings with double volute for larger pumps, which significantly reduce the radial forces. The strain on the radial and axial bearings is considerably reduced, helping them achieve a much longer lifetime.

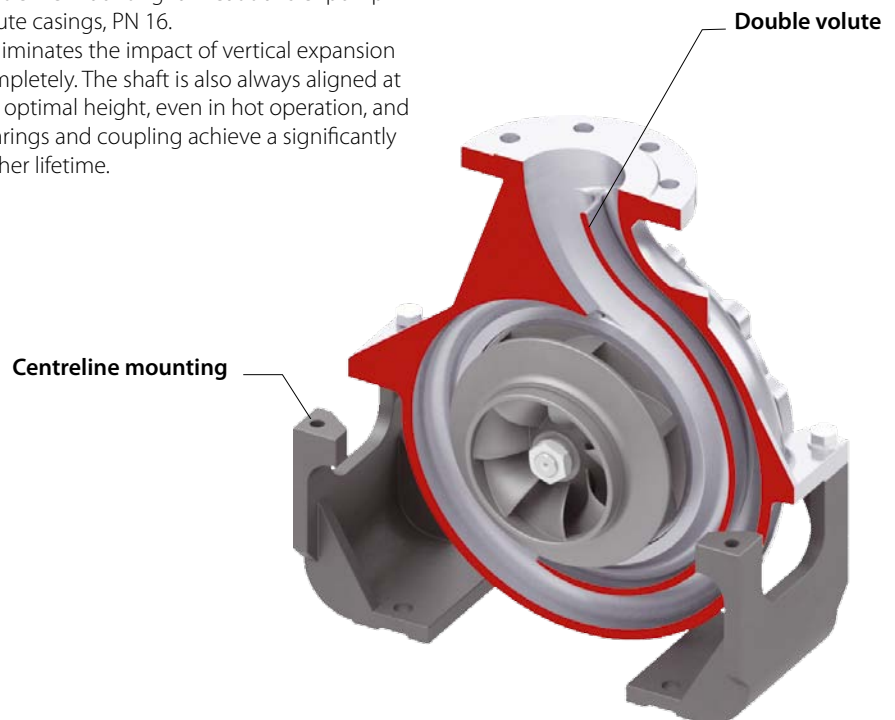

TOE-GN / GA, TOE-MN / MA – Sizes and casing designs

32-160	40-160	50-160	65-160	80-160	100-160	–
32-200	40-200	50-200	65-200	80-200	100-200	125-200
32-250	40-250	50-250	65-250	80-250	100-250	–
Bearing bracket 360			Bearing bracket 470			

All casings with dimensions in accordance with EN 733 Casing with double volute Casing with centreline mounting

Characteristic diagrams and casing designs

TOE-GN / GA, TOE-MN / MA

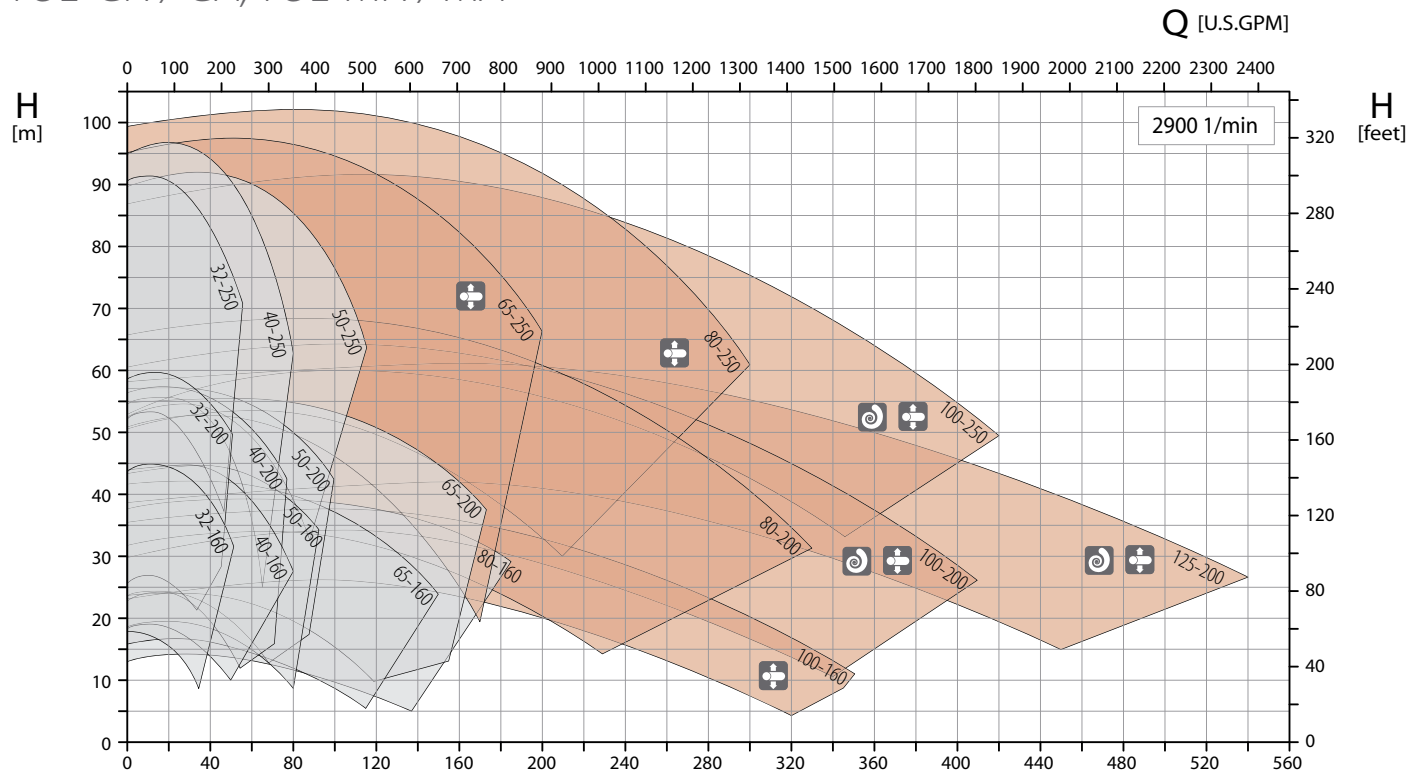

TOE-GI, TOE-MI

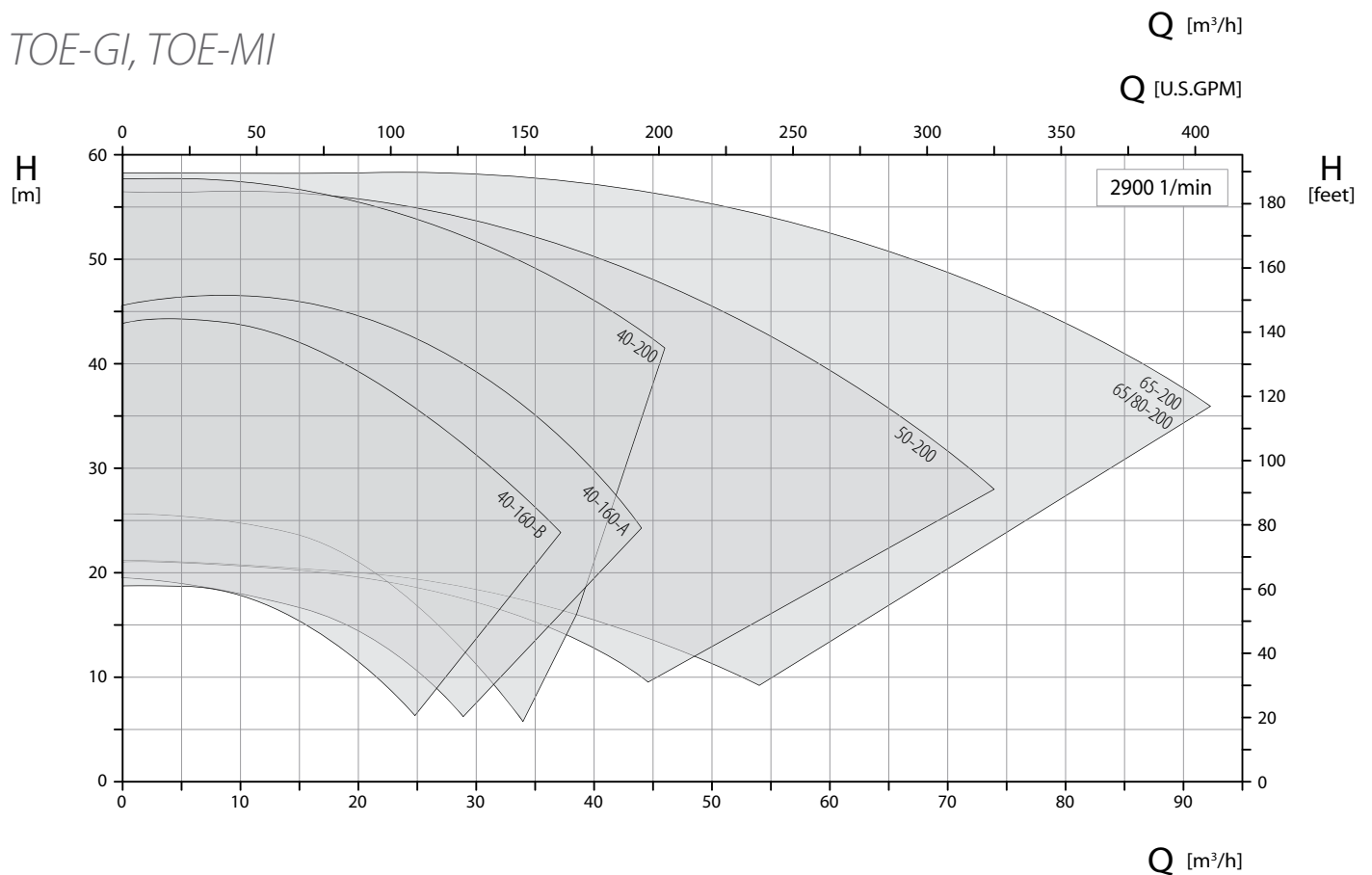

Bearing bracket 360

Bearing bracket 470

Casing with double volute

Casing with centreline mounting

Regenerative turbine pumps with magnetic coupling

Extremely compact, robust, durable and safe



The peripheral impeller transfers the hydraulic output through momentum exchange.

Type-related properties

Due to their design, regenerative turbine pumps have different properties than centrifugal pumps and are the better choice for certain applications.

They achieve relatively high pressures with smaller volume flows, which means that the characteristic curve also runs relatively steep. They belong to the pump types which offer the option of changing the conveying direction through right-left run. They can also pump media containing gas with no problems.

Compact, robust, durable and safe

Regenerative turbine pumps with magnetic coupling from Speck have been used in a wide range of systems and assemblies successfully for many years. The compact design requires minimal installation space and reduces the weight. The perfected pumps also impress with the small number of extremely high-quality parts.

Robust sleeve bearings made from SiC and ceramic shafts guarantee a long lifetime and are free from leakage and maintenance-free thanks to magnetic couplings.

Special designs available on request

On request, Speck can also develop special designs for special media or with different hydraulics. Please contact us.

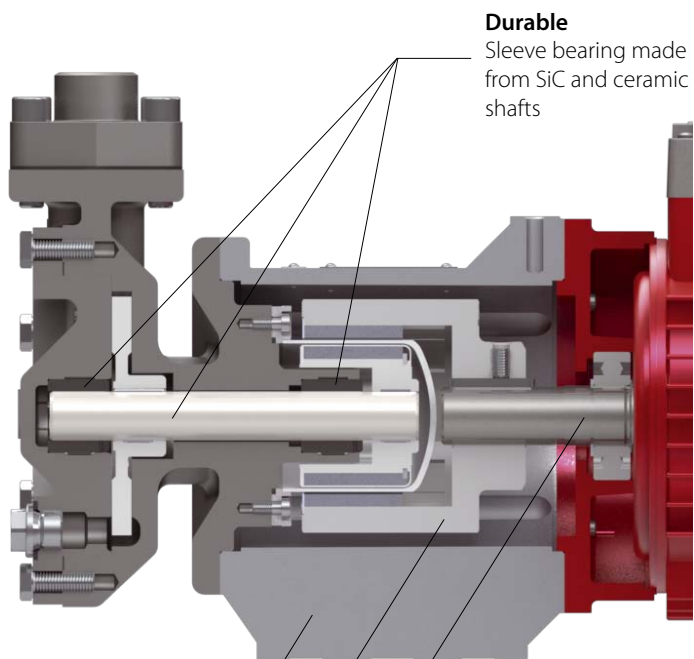

Flexible
Bracket with feet

Safe and maintenance-free
Magnetic coupling

Durable
Sleeve bearing made from SiC and ceramic shafts

Example: CY-6091-MK-TOE

Compact
Close-coupled design and small number of parts

NPY-2251-MK-HT,
NPY-2251-MK-TOE



Illustration not obligatory

	Media	Connections
NPY-2251-MK-HT	Water max. 220 °C	SAE 1/2
NPY-2251-MK-TOE	Oil max. 350 °C	G 1/2, SAE 1/2
Casing	Stainless steel	
Bracket	With or without feet	
Drive 50 Hz	0.50 kW, 3~ 1.00 kW, 3~ on request	
Drive 60 Hz	0.55 kW, 3~ 1.00 kW, 3~ on request	

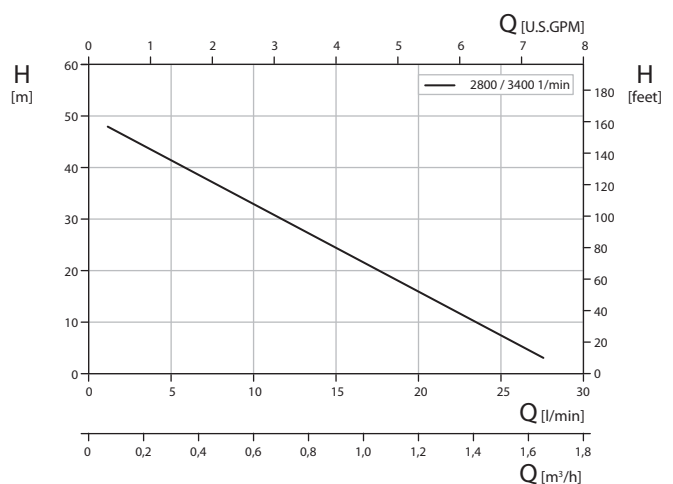

CY-4281-MK-HT,
CY-4281-MK-TOE

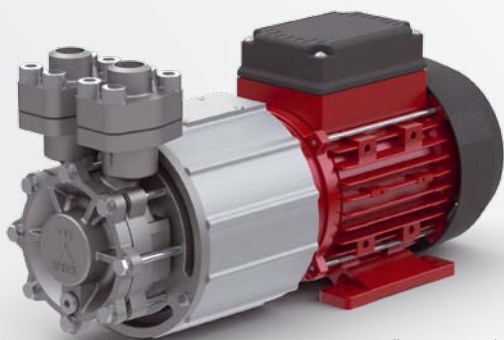

Illustration not obligatory

	Media	Connections
CY-4281-MK-HT	Water max. 220 °C	SAE 3/4
CY-4281-MK-TOE	Oil max. 350 °C	SAE 3/4
Casing	Stainless steel	
Bracket	With or without feet	
Drive 50 Hz	1.00 – 2.20 kW, 3~	
Drive 60 Hz	1.00 – 2.20 kW, 3~	

CY-6091-MK-HT,
CY-6091-MK-TOE

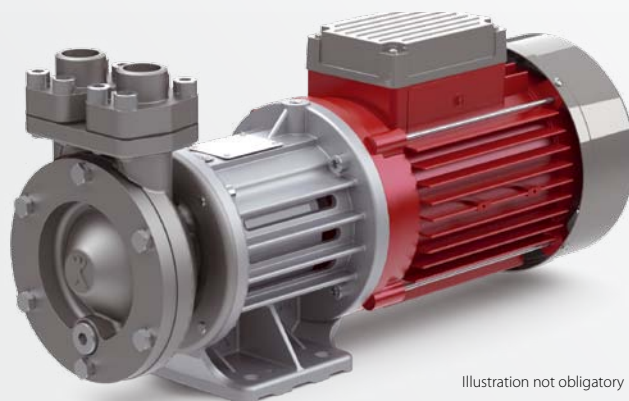

Illustration not obligatory

	Media	Hydraulics	Connections
CY-6091-MK-HT	Water max. 220 °C	Q 80, Q 150	G 3/4, SAE 1
		Q 200	SAE 1 1/4
CY-6091-MK-TOE	Oil max. 180 °C	Q 80, Q 150	G 3/4
	Oil max. 350 °C	Q 80, Q 150	SAE 1
		Q 200	SAE 1 1/4
Casing	Spheroidal graphite iron		
Bracket	With or without feet		
Drive 50 Hz	2.80 – 5.50 kW, 3~		
Drive 60 Hz	2.80 – 5.50 kW, 3~		

