

# Flow Monitors and Sensors

## for intermittent and circulating centralized lubrication systems

Flow monitor



Flow monitors/sensors have the task of monitoring the flow of lubricant from the pump or a piston distributor element to the lube point. Flow monitors with various designs are used for this job. A further task involves monitoring a continuous flow of oil from a pump through a lubrication system. These flow monitors are designed for a throughput ranging from 0,5 cm<sup>3</sup> to 14 000 cm<sup>3</sup>.

Flow sensor



Flow sensors keep an eye on the flow of lubricant from a metering point to the lube point, the metering point metering out a small amount of oil for only a short period of time.

Depending on the type, flow sensors can monitor lubricant quantities ranging from 10 mm<sup>3</sup> all the way to 600 mm<sup>3</sup> per lubricant pulse.

Oil-streak sensor



The oil-streak sensors monitor the continuity of the oil flow in oil+air systems.

So the following points have to be observed when selecting an appropriate monitoring device:

- intermittent or continuous operation
- kind of lubrication system
- lubricant quantity to be monitored
- eff. viscosity of the lubricant
- system pressure.

# Overview flow monitors and -sensors

Please have a look at the important product usage information on the back cover of the brochure.

Designation	Order No.	Metered quantity flow rate	Application	Port A	Port B	Fig..	Page
Flow monitor	171-100-011	0,2 – 1,5 cm <sup>3</sup> /pass	Intermittend totalloss lubrication systems	M10×1	M18×1,5	1	2
Flow monitor	171-210-051	50 – 100	Circulating centralized lubrication systems	M10×1	M18×1,5	2	3
	171-210-052	100 – 200					
	171-210-053	200 – 500 cm <sup>3</sup> /min					
	171-210-054	500 – 800					
	171-210-055	800 – 1800					
Flow monitor	171-210-061	1,6 – 2,5	Circulating centralized lubrication systems	M18×1,5	M18×1,5	3	3
	171-210-062	2,3 – 4,0					
	171-210-063	3,6 – 6,0 l/min					
	171-210-064	5,5 – 10,0					
	171-210-065	8,0 – 14,0					
Flow sensor	GS300 GS304N GS304P	10 – 600 mm <sup>3</sup> /Impuls	Intermittend centralized lubrication systems, e.g. with piston distributors, metering elements, injection oilers		4	8	
Oil-streak sensor	GS4011-S20	120 – 600	Oil+air centralized lubrication systems for assembling very close to the lube point			5	9
	GS6011-S20	120 – 600 mm <sup>3</sup> /h					
	GS4011-S50	60 – 120					
	GS6011-S50	60 – 120					
Oil-streak sensor	GS4011-S300 GS6011-S300	ab 2 mm <sup>3</sup> /Impuls	Oil+air centralized lubrication systems for assembling very close to the mixing valve		5	9	

Please note: See leaflet 1-1730-EN for associated line sockets.

## Flow monitors for monitoring of an intermittend flow of oil

### Totalloss lubrication systems

Fig. 1

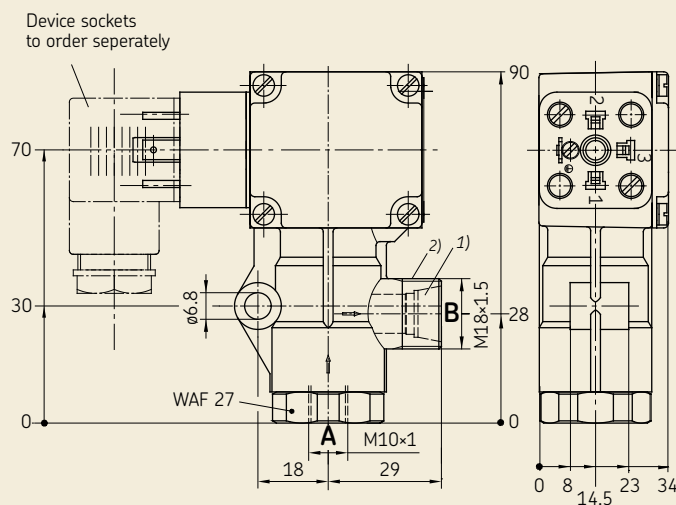

Note: See application 1, page 4.

1) Port tapped for cutting-sleeve screw union EO-2 DIN 2353 / ISO 8434-1  
 2) DIN 2353 / ISO 8434-1. Only permissible for the use of preassembled fittings.  
 We recommend use of a preassembled EO-2 screw union.  
 (Example: GA21...23/GA30)

#### Technical data

Number of cycles ..... max. 2/min<sup>3)</sup>  
 Operating viscosity ..... 20-750 mm<sup>2</sup>/s  
 Actuating pressure ..... min. 4 bars<sup>4)</sup> max. 30 bars  
 Electr. switching ..... changeover 250 V AC, 0,5 A  
 Type of enclosure ..... IP 44  
 Mounting position ..... any

#### Materials:

Housing ..... die-cast zinc, polyamide  
 Seals ..... NBR (FKM version on request)

<sup>3)</sup> Suitable for medial operating viscosity. In case of higher viscosity decreases the number of cycles.

<sup>4)</sup> In single line centralized lubrication systems the main line needs to have before the distributors a pressure of at least 14 bars.

Order No.	Flow rate
171-100-011	0,2 – 1,5 cm <sup>3</sup> /pass

# Flow monitors for the monitoring of a continuous flow of oil

circulating lubrication systems with 50 bis 1800 cm<sup>3</sup>/min or 1,6 bis 14 l/min

Fig. 2

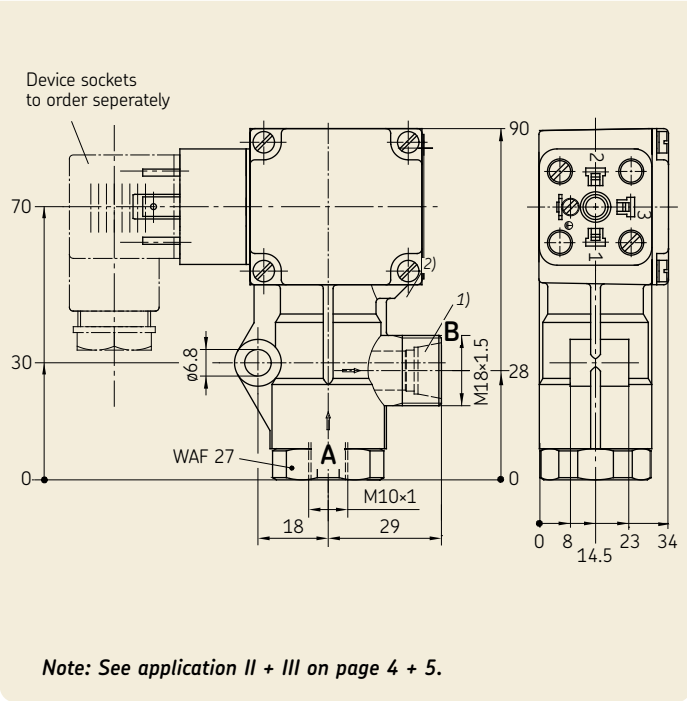

**Technical data**

- Operating viscosity ..... 20 – 1000 mm<sup>2</sup>/s
- Actuating pressure ..... min. 4 bars <sup>3)</sup>, max. 25 bars
- Electr. switching ..... changeover 250 V AC, 0,5 A
- Perm. operating temperature ..... + 5 bis +80 °C
- Type of enclosure ..... IP 65
- Mounting position ..... any
- Materials:**
- Housing ..... die-cast zinc, polyamide
- Seals ..... NBR (FKM version on request)

<sup>3)</sup> If the flow monitors are equipped with metering restrictors, at least 6 bars are required in the feed line

Order No. (Fig. 2)	Flow rate
171-210-051	50 – 100
171-210-052	100 – 200
171-210-053	200 – 500 cm <sup>3</sup> /min
171-210-054	500 – 800
171-210-055	800 – 1800

Fig. 3

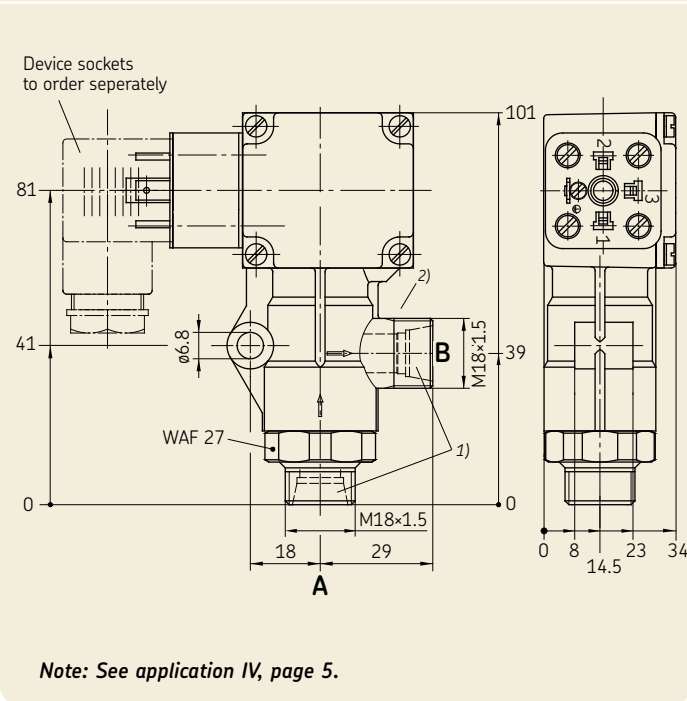

Order No. (Fig. 3)	Flow rate
171-210-061	1,6 – 2,5
171-210-062	2,3 – 4,0
171-210-063	3,6 – 6,0 l/min
171-210-064	5,5 – 10,0
171-210-065	8,0 – 14,0

<sup>1)</sup> Port tapped for cutting-sleeve screw union E0-2 DIN 2353 / ISO 8434-1  
<sup>2)</sup> DIN 2353 / ISO 8434-1. Only permissible for the use of preassembled fittings. We recommend use of a preassembled E0-2 screw union. (Example: GA21...23/GA30)

# System examples and connection fittings

## I. Singleline, totalloss lubrication system with piston distributors

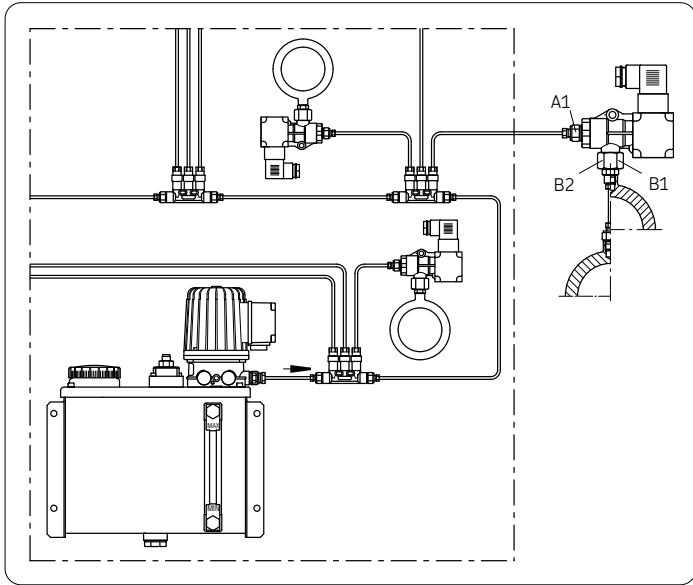

## II. Circulating lubrication system with multicircuit pump unit

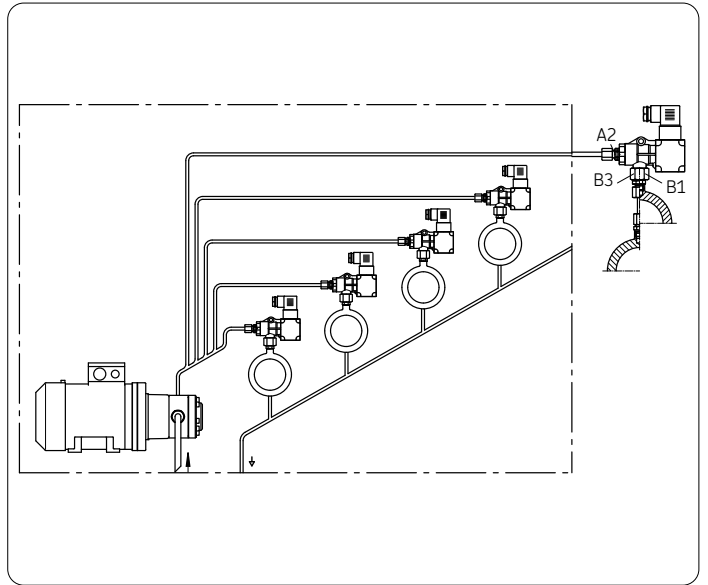

### Connection fittings I

#### Straight screw-in connector <sup>1)</sup>

Connection	for tubing diam.	Socket union order No.	Double tapered ring order No.	Adapter order No.	Washer order No.
A1	4	404-002	404-001	404-006	504-019

#### Connection fittings with screwed stud end

for direct attachment of flow monitor to the lube point

Connection	Adapter Order No.	d1
B1	GA21	M10x1
	GA22	M10x1 tap.
	GA23	R1/8 tap.
	GA24	R1/4 tap.

#### Connection fitting for tubing <sup>1)</sup>

Connection	for tubing diam.	Adapter order No.	d2	Socket union order No.	Double tap. ring order No.
B2	4	GA30	M8x1	404-002	404-001

### Connection fittings II

#### Connection piece without restrictor <sup>2)</sup>

Straight screw-in connector

Connection	for tubing diam.	Union nut order No.	Cutting sleeve order No.	Adapter order No.	Washer order No.
A2	6	406-302	406-301	GD60.02	
	8	408-302	408-301	GD80.02	504-019
	10	410-302	410-301	GD100.02	

#### Connection fitting for tubing <sup>2)</sup>

Connection	for tubing diam.	Adapter order No.
B3	6	473-806-391
	8	473-808-392
	10	473-810-391

### Connection

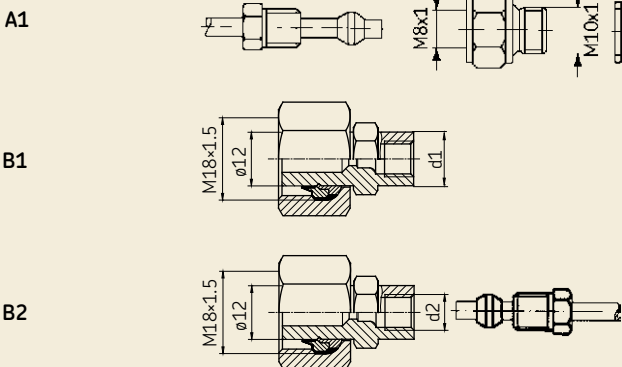

### Connection

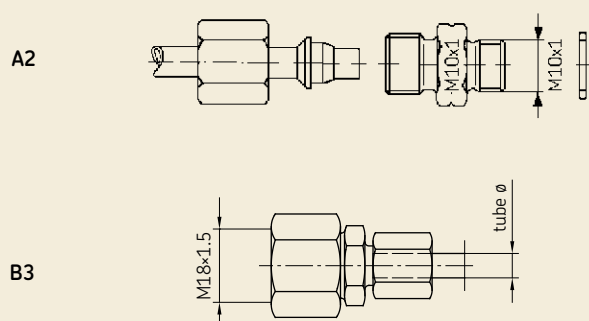

# System examples and connection fittings

## III. Circulating lubrication system with restrictors

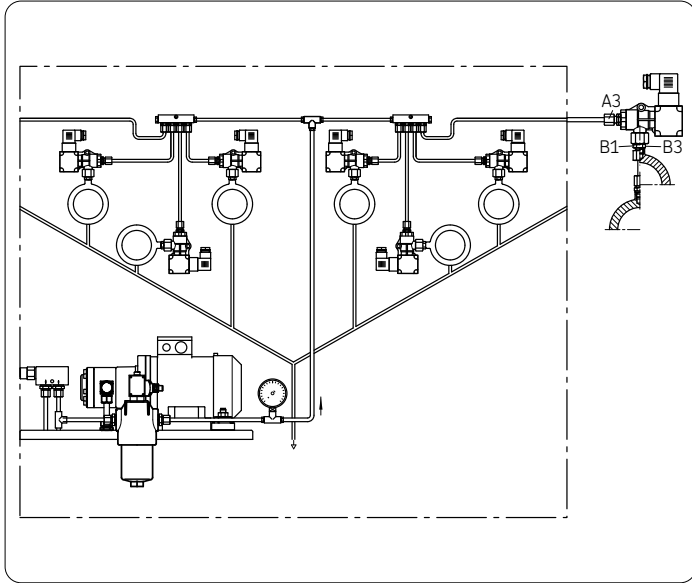

## IV. Circulating lubrication system with restrictor tubes

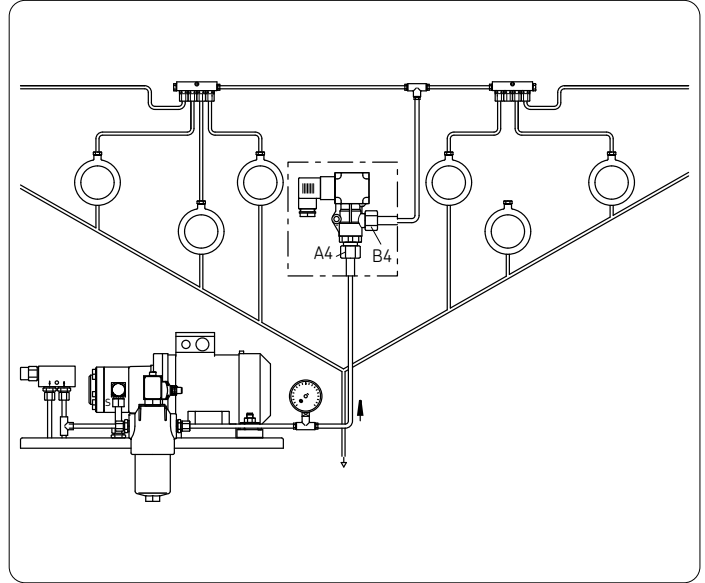

### Connection fittings III

**Connection piece with restrictor <sup>2)</sup>**  
Straight screw-in connector

Connection	for tubing diam.	Union nut order No.	Cutting sleeve order No.	Adapter with restrictor (compl. with washer) order No.	code No.
A3	6	406-302	406-301	GD60	60
				GD61	61
				GD62	62
				GD63	63
				GD64	64
	8	408-302	408-301	GD65	65
				GD80	80
				GD81	81
				GD82	82
				GD83	83
			GD84	84	
			GD85	85	
			GD86	86	
			GD87	87	
			GD88	88	
			GD89	89	

### Connection fittings IV

**Only for a range of 1.6 to 14 l/min**  
(flow monitor as per Fig. 2, page 3)

**Tube union <sup>2)</sup>**  
for direct connection to the flow monitor

Connection	for tubing diam.	Function nut order No.
A4	12	460-212-001

<sup>1)</sup> Port tapped for solderless tube connection

<sup>2)</sup> Port tapped for solderless cutting-sleeve screw union to DIN 2353

### Connection

A3

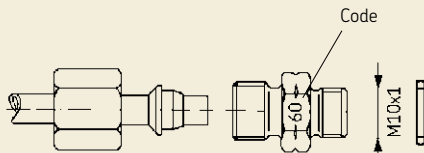

The required restrictor sizes are determined with the nomograph on page 6

### Connection

A4

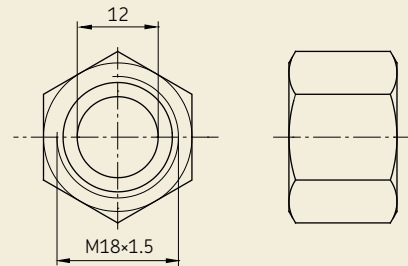

# Nomograph for determination of restrictor sizes

(connection A3, system example III)

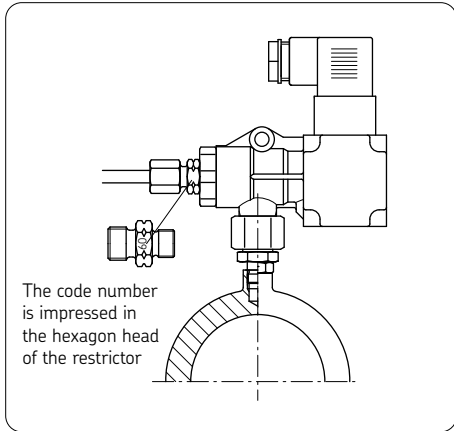

## Determining the restrictor size

1. Draw a straight line along the index lines through point **Q** v effective.
2. Determine the point at which **p** intersects with this line, resulting in **D**.
3. Select the restrictor **closest** to point **D**.

**D** must be inside the white field, that means small amounts cannot be "apportioned and monitored" with the unit.

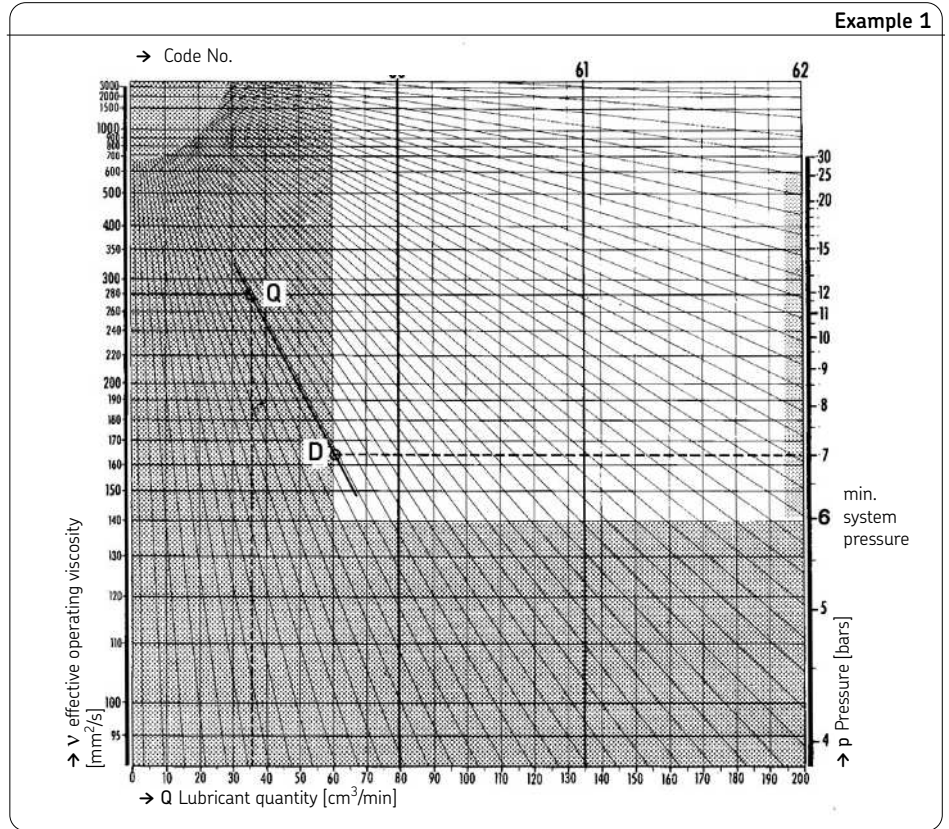

### Example 1:

required:  $Q = 36 \text{ cm}^3/\text{min}$ ,  
 given:  $v \text{ eff.} = 280 \text{ mm}^2/\text{s}$   
 $p = 7 \text{ bars}$   
 Result: restrictor size No. 60  
 (borderline case)

### Example 2:

required:  $Q = 260 \text{ cm}^3/\text{min}$ ,  
 given:  $v \text{ eff.} = 480 \text{ mm}^2/\text{s}$   
 $p = 8 \text{ bars}$   
 Result: restrictor size No. 80

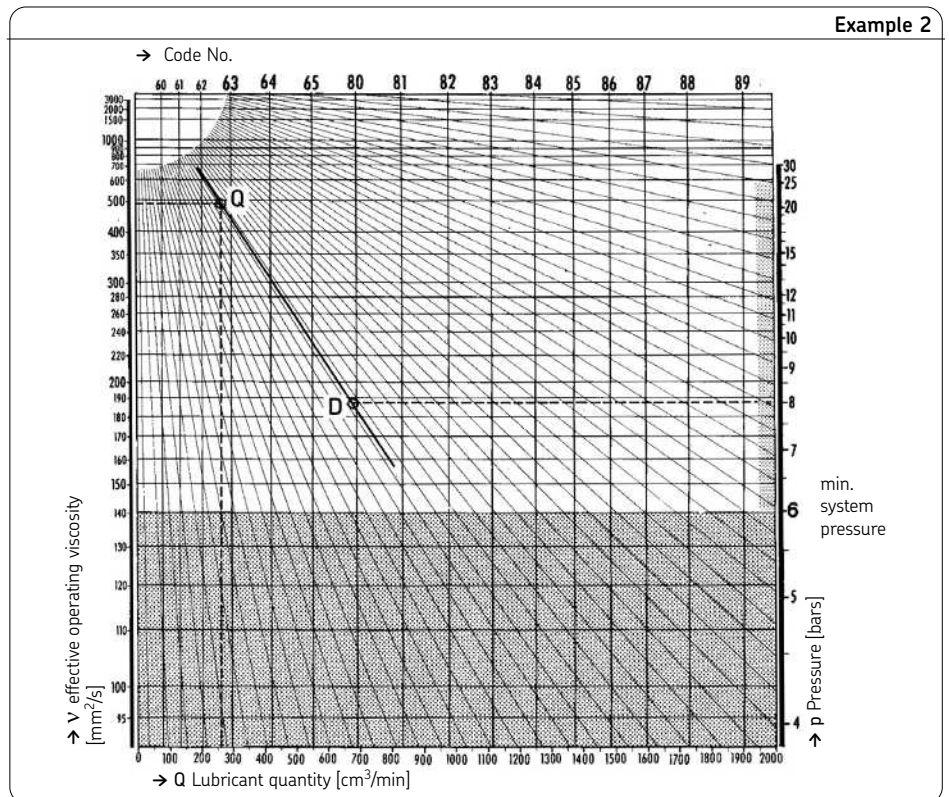

## Flow rate at activation point as a factor of the viscosity

Flow monitors to monitor a flow of oil (circulating lubrication system)

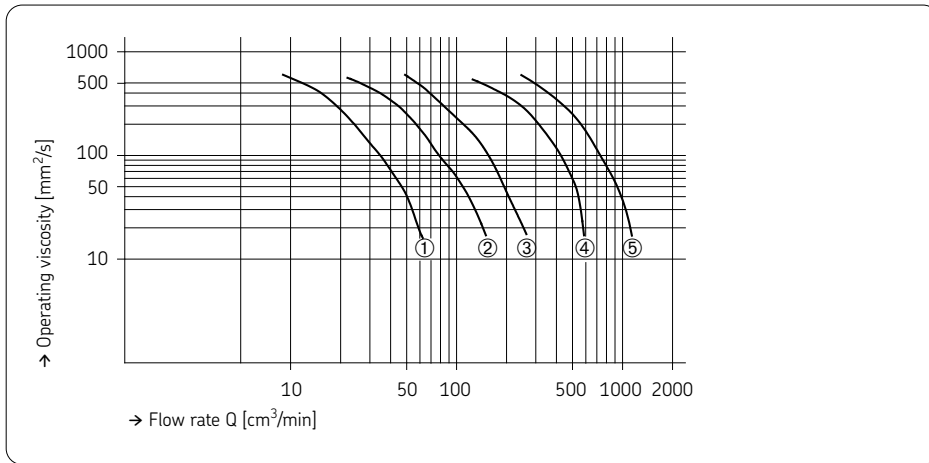

Order No.	Flow rate activation point [cm <sup>3</sup> /min]	Actuation curve as per diagram
171-210-051	35	①
171-210-052	75	②
171-210-053	150	③
171-210-054	400	④
171-210-055	700	⑤

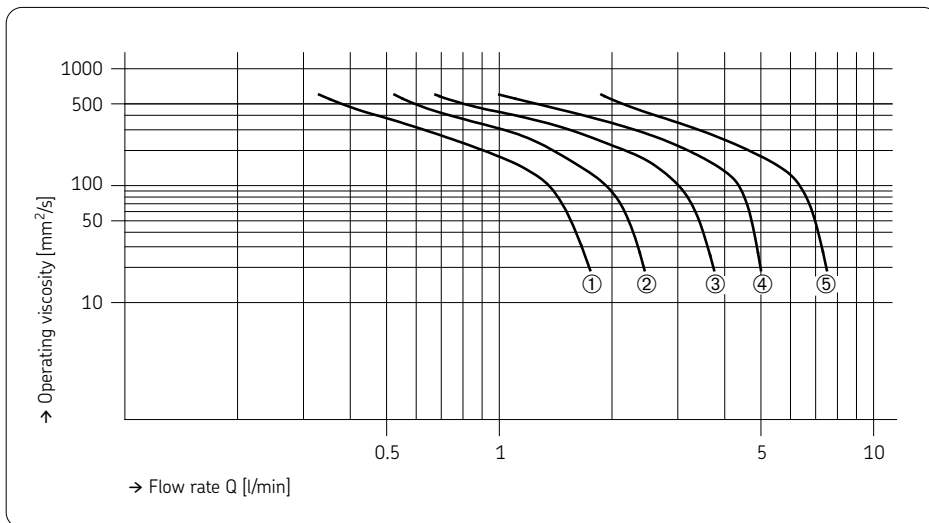

Order No.	Flow rate activation point [l/min]	Actuation curve as per diagram
171-210-061	1.3	①
171-210-062	1.9	②
171-210-063	3.0	③
171-210-064	4.5	④
171-210-065	6.5	⑤



# GS4011-S., GS6011-S..

The oil-streak sensors monitor the continuity of the oil flow in oil+air lubrication systems

Fig. 5

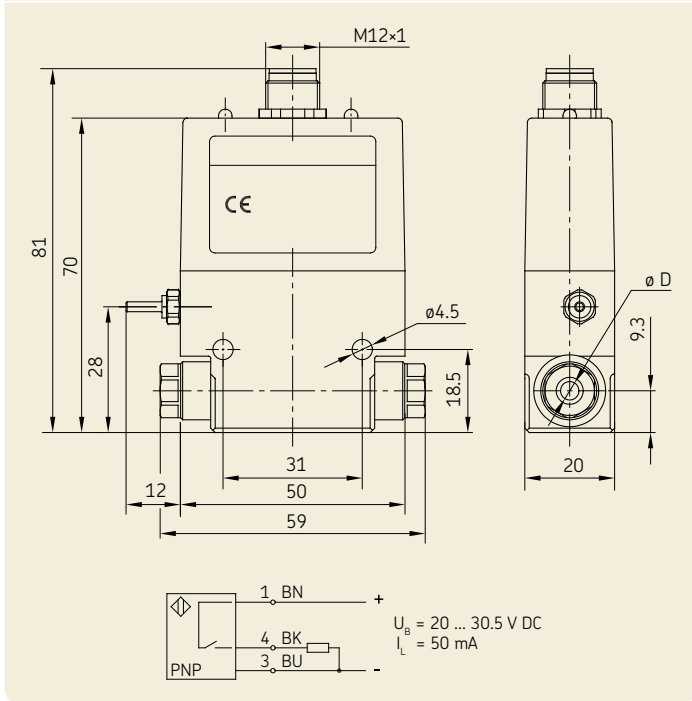

So-called oil+air centralized lubrication systems are used to supply high-speed rolling bearings in tool spindles. The bearings are supposed to be supplied with extremely small quantities of lubricant (minimal-quantity lubrication) in the case of these applications. To achieve such small quantities of oil per unit of time, what was originally a relatively large drop of oil is torn apart by a current of air on its way from the metering point to the bearing. The oil to be delivered is fed in the line to the bearing as a thin flow of lubricant along the wall.

**Monitoring:**

So far, only the metered quantity of oil from the metering element has been checked upstream of the oil and air mixing point. The oil-streak sensor makes it possible to monitor the transport of a fine current of oil along the secondary line's wall downstream of the oil and air mixing point. The closer the sensor is located to the lube point, the more reliable the system monitoring.

**Technical data**

- Measuring principle..... optical
- Fluid ..... oil+air
- Max. operating pressure ..... 10 bars
- Operating temperature ..... 0 to +60 °C
- Mounting position ..... horizontal, no swivel drive (GS4011-S300 and GS6011-S300 also vertical)

**Electrical data**

- Rated voltage  $U_N$  ..... 24 V DC <sup>1)</sup>
- Operating range  $U_B$  ..... 20 to 30.5 V DC
- Max. power consumption  $I_E$  ..... 40 mA
- Type of enclosure ..... IP54
- Outputs ..... pnp type  
*closes when oil streaks detected, opens when there are none*
- Color coding with standard sensor cables:
  - brown (BN) ..... + 24 V
  - blue (BU) ..... GND
  - black (BK) ..... make contact
  - white (WH) ..... break contact

<sup>1)</sup> Protective measure to be taken for operation in conformity with "Functional Extra-Low Voltage with Safety Separation" (PELV = Protective Extra-Low Voltage)

**Accessories:**  
 Connection cable with straight cable socket, 4-pole type, length 5 m, order No. 179-990-600  
 Socket, 90° angled, order No. 179-990-372

Order No.	Plastic tubing $\varnothing$ D	Flow rate
GS4011-S20	4	120 – 600 mm <sup>3</sup> /h
GS4011-S50	4	60 – 120 mm <sup>3</sup> /h
GS6011-S20	6	120 – 600 mm <sup>3</sup> /h
GS6011-S50	6	60 – 120 mm <sup>3</sup> /h
GS4011-S300	4	from 2 mm <sup>3</sup> /pulse
GS6011-S300	6	from 2 mm <sup>3</sup> /pulse



**Order No. 1-1704-EN**

Subject to change without notice! (03/2021)

**Important product usage information**

All products from SKF may be used only for their intended purpose as described in this brochure and in any instructions. If operating instructions are supplied with the products, they must be read and followed.

Not all lubricants are suitable for use in centralized lubrication systems.

SKF does offer an inspection service to test customer supplied lubricant to determine if it can be used in a centralized system. SKF lubrication systems or their components are not approved for use with gases, liquefied gases, pressurized gases in solution and fluids with a vapor pressure exceeding normal atmospheric pressure (1013 mbars) by more than 0.5 bar at their maximum permissible temperature.

Hazardous materials of any kind, especially the materials classified as hazardous by European Community Directive EC 67/548/EEC, Article 2, Par. 2, may only be used to fill SKF centralized lubrication systems and components and delivered and/or distributed with the same after consulting with and receiving written approval from SKF.

**Further brochures:**

1-0103-EN Fittings and Accessories

1-1730-EN Electric Plug-and-Socket Connectors

1-9201-EN Transport of Lubricants in Centralized Lubrication Systems

This brochure was presented by:

® SKF is a registered trademark of the SKF Group.

© SKF Group 2021

The contents of this publication are the copyright of the publisher and may not be reproduced (even extracts) unless prior written permission is granted. Every care has been taken to ensure the accuracy of the information contained in this publication but no liability can be accepted for any loss or damage whether direct, indirect or consequential arising out of the use of the information contained herein.

