

# Pressure relief pilot operated poppet type and anti-cavitation valve Special cavity, LG

VMR2-22-LG

VMR2.240.LG

**RE 18318-38**

Edition: 09.2025

Replaces: 07.2023



Technical data	
Max. operating pressure port 1 (P)	420 bar (6000 psi)
Max. pressure admitted port 2 (T)	50 bar (725 psi)
Max. flow	240 l/min (63 gpm)
Max. internal leakage <sup>1)</sup>	45 drops/min.
Fluid temperature range	-20 to 120 °C (-4 to 248 °F) (Viton)
Installation torque <sup>2)</sup>	120 Nm (89 ft-lbs)
Weight	0.28 kg (0.62 lbs)
MTTFd	150 years see RE 18350-51
Special cavity	LG (see data sheet 18325-75)
Lines bodies and standard assemblies	Please refer to section "Hydraulic integrated circuit" or consult factory
Seal kit (Viton) <sup>3)</sup>	Code: RGLGR2040520100 material no: R930054948
Fluids	Mineral-based or synthetics with lubricating properties at viscosities of 10 to 380 mm <sup>2</sup> /s (cSt)
Recommended degree of fluid contamination	Nominal value max. 10µm (NAS 9) / ISO 4406 20/18/15
Installation position	No restrictions
Other Technical Data	See data sheet 18350-50
Without surface protection	In case of need of surface protection, please consult factory.

## Description

Flow is blocked from 1 to 2 until pressure increases to meet the selected valve setting, lifting the conical, pilot-stage poppet from its seat. This action exhausts oil above the main-stage poppet (low-leakage, seat type), allowing it to shift and provide relief flow through 2 to tank. Pressure at 2 is additive to the relief setting of the valve.

The anti-cavitation function makes up for lacking oil volumes caused, for example, by leakage when pressure valves respond or in the case of leading loads. If the pressure at main port 1 is lower than the one at main port 2, the spool will be lifted out of its seat. Hydraulic fluid flows from main port 2 to main port 1.

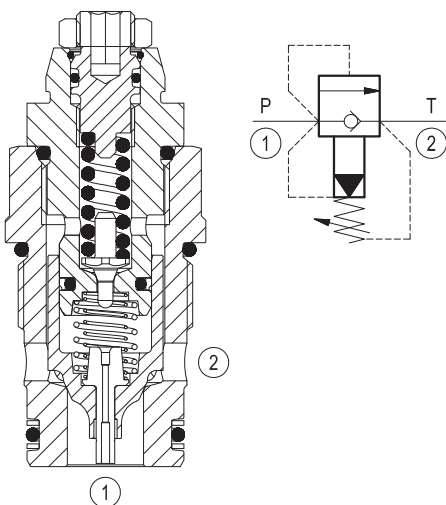

## Characteristic curve

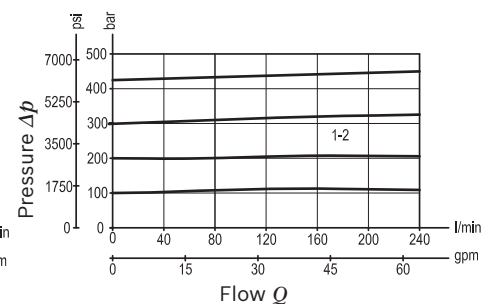
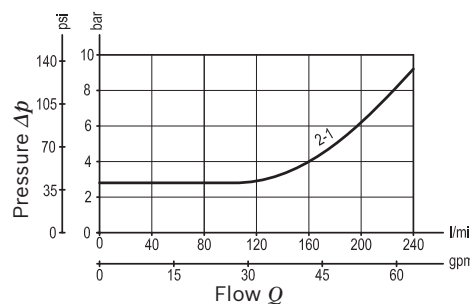

1) At 80% of pressure setting.

2) Torque value valid for installation in cast iron and steel manifolds. In case of different body materials, please consult factory.

3) Only external seals for 10 valves.

4) Zinc coated option available upon request

**Ordering code**

<b>VMR2.240</b>	*	*	*
-----------------	---	---	---

Pressurerelefpilotoperatedpoppettype  
and anti-cavitation valve

Cavity **LG**

		SPRINGS		O-RING
		Adj. press. range bar (psi)	Pressure increase bar/turn (psi/turn)	Material
<b>LG</b>	<b>000</b>	100-420 (1450-6090)	300 (4350)	Viton (FKM)
<b>LG</b>	<b>010</b>	100-420 (1450-6090)	300 (4350)	Viton (FKM)

\* Valves are delivered at minimum pressure setting and with nut not tighten.  
Fine setting to be done by customer.  
For case of request of factory set valve, please consult factory.

**Preferred types**

Type	Material number
VMR2.240.LG.000	R930102100
VMR2.240.LG.010	R930054929

Type	Material number

**Dimensions**

