

Type 2724-2726 pH/ORP Electrodes

General Purpose

Compatible with ALL pH/ORP instruments and SmartPro transmitters



Product description

The 2724-2726 pH and ORP electrodes are general purpose sensors ideal for a wide range of applications. These feature a patented reference design and uses the unique foul-proof patented DryLoc® connector. The large area PE reference junction and pathway is constructed to increase the total reference effectiveness and ensures long service life.

The DryLoc® connector with corrosion resistant gold plated contacts readily connects the sensor to the mating 2751 pH/ORP Smart Sensor Electronics. The robust PPS threaded sensor body and choice of flat pH, bulb pH, or flat ORP sensing elements allows a broad range of chemical and mechanical compatibility for a wide variety of applications.

There are two optional pH sensing versions available, HF and LC. The HF version is for applications where traces of hydrofluoric acid (2% or less) will attack standard pH glass. The LC version can be used for low conductivity fluids 20–100 $\mu\text{S}/\text{cm}$ nominal.

The 2724-2726 electrodes incorporate o-ring seal for use with ½" to 4" GF Installation fittings. They can also be mounted directly into reducing tees, DN20 to DN100 (¾ to 4 inch). Sensor tip must be in flow path.

Features

- Patented reference design for exceptional performance and prolonged life
- UHMW polyethylene reference junction
- Memory chip enabled for access to a wide range of unique features when connected to the 751 pH/ORP Smart Sensor Electronics
- PPS body for broad range of chemical compatibility
- Patented DryLoc® connector with gold plated contacts
- Special design allows for installation at any angle, even inverted or horizontal
- Mounts in GF standard installation fittings from DN15 to DN100 (½ to 4 in.)
- ¾" NPT or ISO 7/1-R ¾ threaded sensors for use with reducing tees DN20 to DN100 (¾ to 4 in.)
- Quick temperature response
- Bulb and flat HF resistant glass available for trace HF, in less than 2% concentration applications
- Low conductivity sensor available for liquids from 20–100 µS/cm



* U.S. Patent Nos.: 6,666,701, 7,799,193 B2, 7,867,371 B2 and 8,211,282 B2

Applications

- Monitoring
- Industrial Water Treatment
- Municipal Water Treatment
- Aquaculture
- Aquatic Life Support System
- Agriculture
- Water Parks

Specifications

General

Performance	Efficiency	>97% @ 25 °C (77 ° F)
Operating Range	pH	0 to 14 pH
	ORP	±2000 mV
	3-2726-LC	Low conductivity fluids; 20 - 100 µS/cm nominal < 20 µS; flow must be less than 150 ml/min in a properly grounded system
	3-2724-HF, 3-2726-HF	Hydrofluoric acid resistant glass, pH 6 or below; trace HF <2%

Compatibility

2751 Smart Sensor Electronics (for 9900, 9950, 4 to 20 mA or Profibus Concentrator),

Temperature Sensor

Pt1000 versions	Compatible with 2751 pH/ORP Smart Sensor Electronics for connection to a PLC or to the 9900 or 9950 instruments
3 KΩ Balco versions	Compatible with the 3-2750 and the 3-2751 smart electronics to connect to the 9900 and 9950. Compatible with the 3-2760-XX pre-amplifier to connect to the 3-8750.

Process Connection

¾ in. NPT	ISO 7/1-R 3/4	Mounts into fittings
-----------	---------------	----------------------

Wetted Materials

pH	PPS, glass, UHMW PE, FKM
ORP	PPS, glass, UHMW PE, FKM, Platinum

Max. Temperature/Pressure Rating

Operating Temperature Range* bulb tip design	0 °C to 85 °C	32 °F to 185 °F
	flat tip design	10 °C to 85 °C
Operating Pressure Range	6.8 bar @ -10 to 65 °C (100 psi @ 14 to 150 °F)	
	4 bar @ 65 to 85 °C (58 psi @ 150 to 185 °F)	

*Best performance for 2724-HF, 2726-HF sensors is above 10 °C (50 °F)

Recommended Storage Temperature

0 °C to 50 °C	32 °F to 122 °F
---------------	-----------------

The electrode glass will shatter if shipped or stored at temperature below 0 °C (32 °F)

The performance life of the electrode will shorten if stored at temperatures above 50 °C (122 °F)

Mounting

In-line Mounting	Use GF Installation fittings ½" to 4"
	Reducing tees ¾"-4". Sensor tip must be in flow.
	Sensor can be mounted at any angle
Submersible Mounting	Use threads on model 2751-3/-4
	Requires ¾ inch NPT or ISO 7/1-R 3/4 male threaded liquid tight extension conduit.

Shipping Weight

0.25 kg	0.55 lb
---------	---------

Standards and Approvals

RoHS compliant, China RoHS
Manufactured under ISO 9001, ISO 14001 and ISO 45001

See pressure-temperature diagrams for more information.

Dimensions

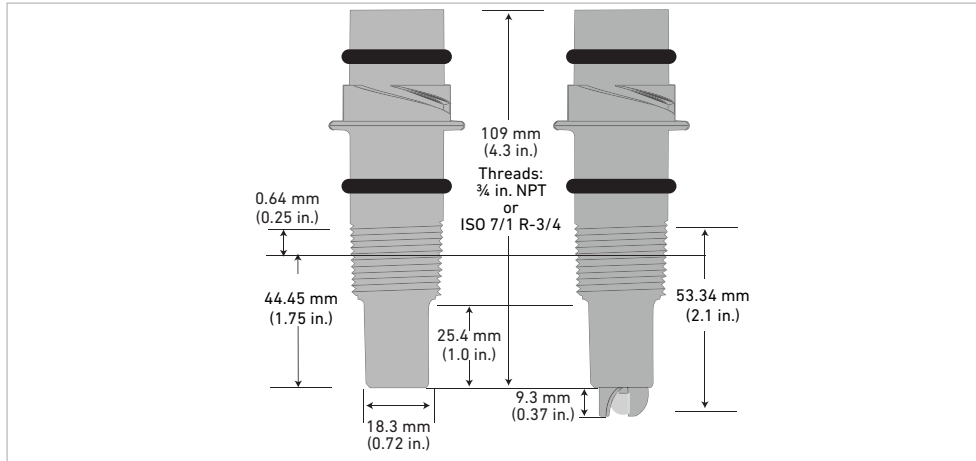



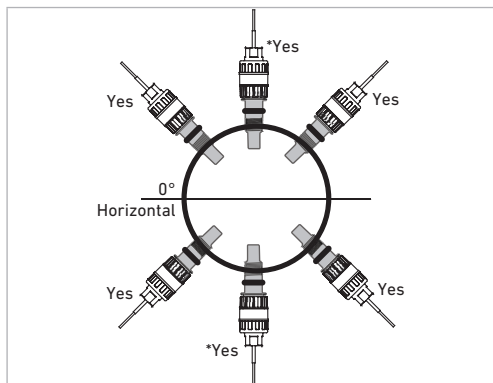

Mounting Angle



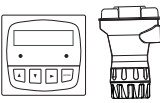

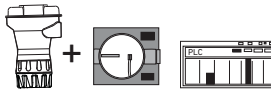
Types 2724-2726 may be mounted at any angle without affecting the performance.
*Avoid locations with air pockets and sediment.

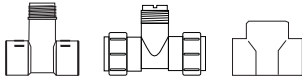

System Overview

Panel Mount	Pipe, Tank, Wall	4 to 20 mA Output	Automation System
<p>GF Instruments with 2751 Smart Sensor Electronics - 9900 - 9950</p> 	<p>GF Instruments with 2751 Smart Sensor Electronics - 9900 and Rear Enclosure</p> 	<p>2751 Smart Sensor Electronics with - Customer Supplied Chart Recorder or Programmable Logic Controller or - Programmable Automation Controller</p> 	<p>2751 Smart Sensor Electronics with - 0486 Profibus Concentrator and Customer Supplied Programmable Logic Controller or - Programmable Automation Controller</p> 
<p>Type 2724-2726 DryLoc® pH/ORP Electrodes</p> 			

All sold separately

Panel Mount	Pipe, Tank, Wall	4 to 20 mA Output	Automation System
<p>In-Line Installation - GF and threaded ½ in to 4 in fittings only Reducing tees ¾"-4". Sensor tip must be in flow.</p> 		<p>Submersible Installation - Customer supplied pipe extension or conduit with ¾ in. NPT or ISO 7/1-R ¾ threads</p> 	

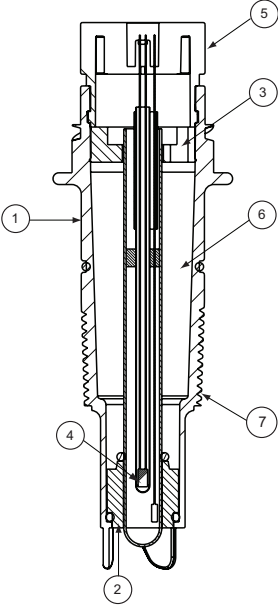
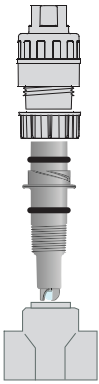
Electrode Key Features and Benefits:

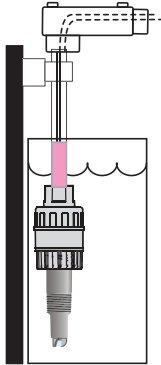
			
<p>Dual-patented reference design for long life in conductivity or chemicals.</p>	<p>(7) Sensor in threaded reducing tee</p>	<p>(8) Sensor in fitting</p>	<p>(9) Sensor submersible installation</p>

1. PPS body for chemical compatibility with most harsh chemicals.
2. Porous UHMW PE (ultra high molecular weight polyethylene) junction resists fouling and build-up.
3. Memory chip enabled for convenient data storage and access (calibration data, operational data, and manufacturing data), electrode health monitoring via glass impedance measurement when used in connection with the 2751 pH/ORP Smart Sensor Electronics.
4. Internal temperature sensor located in the glass stem for a quick temperature response.
5. DryLoc® connector with corrosion resistant gold plated pins for quick and easy sensor removal. Resists moisture and dirt intrusion.
6. Dual-patented reference design with a 406 mm (16 in.) reference pathway for prolonged life in harsh environments. This enables the sensor to last significantly longer than other standard pH/ORP electrodes in most applications.
- 6a. With the patented reference design, the 2726-LC version performs better in low conductivity water between 20 - 100 μ S and lasts longer than previous "DI" electrodes.
- 6b. The 2726-LC sensor also performs in applications with extremely low (less than 20 μ S) conductivity. Special precautions must be taken to avoid measurement complications.
Please note the following.
 - Electrostatic charges (streaming potentials) can cause dramatic offsets in a system with very low conductivity water. To minimize this, sensors should be placed in a well grounded system.
 - To enhance performance, a low flow cell is recommended to provide a steady flow rate (150 ml/minute). Sensors placed in high flow applications will experience noisier readings due to streaming potential.
7. Threads for NPT or ISO process connection into reducing tees.
 - Use off-the-shelf reducing tees DN20 to DN100 (¾ to 4 in.). Sensor tip must be in flow.
8. Mounts directly into GF installation fittings (½ to 4 in.).
9. Mount submersed into a tank via the 2751-3(-4), ¾" F-NPT back threads.

Pressure-temperature diagram

i The pressure-temperature diagram are specifically for the sensor. During system design the specifications of all components must be considered. In the case of a metal piping system, a plastic sensor will reduce the system specification.

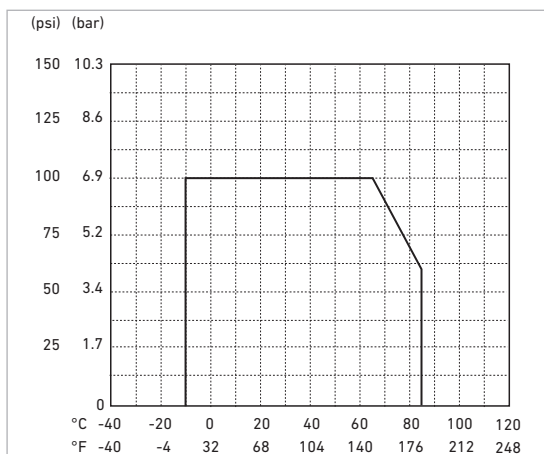

Application Tips

- Use the flat glass electrodes when a self-cleaning feature is desired; especially useful in applications with abrasive chemicals for in-line installations.
- Use bulb protected electrodes for low temperature applications or where fast response is required.
- ORP electrodes are generally used for chemical reaction monitoring, not control.
- Ensure that sensor materials are chemically compatible with the process liquid.
- Keep electrode tip wet, avoid air pockets and sediment.

Buffer Solution

3822-7004
3822-7007
3822-7010

Quinhydrone

3822-7115



The pH buffers are ideal for calibration. The liquid solutions are conveniently packaged in one pint (473 ml) bottles. pH buffer kits in powder pillows are available for mixing fresh solutions with water at the time of use.

All pH buffers are color coded for easy identification; 4.01 pH is red, 7.00 pH is yellow, and 10.00 pH is blue.

All pH buffers are traceable to NIST standards. The 4.01 and 7.00 buffer solutions can be used to calibrate ORP sensors when saturated with quinhydrone

Ordering Information

Type 2724-2726 Ordering Notes

Mfr. Part No.	Code	Tip Design	Process Connection Thread Options
pH Electrodes			
Temperature element Pt1000; use with 2751 pH/ORP Smart Sensor Electronics* and Profibus Concentrator			
3-2724-00	159 001 545	Flat	¾ in. MNPT, Thread
3-2724-01	159 001 546	Flat	ISO 7/1-R 3/4 Thread
3-2726-00	159 001 553	Bulb	¾ in. MNPT, Thread
3-2726-01	159 001 554	Bulb	ISO 7/1-R 3/4 Thread
3-2726-HF-00	159 001 549	Bulb, HF Resistant ¹	¾ in. MNPT, Thread
3-2726-HF-01	159 001 550	Bulb, HF Resistant ¹	ISO 7/1-R 3/4 Thread
3-2726-LC-00	159 001 557	Bulb, Low Conductivity ²	¾ in. MNPT, Thread
3-2726-LC-01	159 001 558	Bulb, Low Conductivity ²	ISO 7/1-R 3/4 Thread
Temperature element 3 KΩ Balco; Compatible with both the 2751 pH/ORP Smart Sensor Electronics*			
3-2724-10	159 001 547	Flat	¾ in. MNPT, Thread
3-2724-11	159 001 548	Flat	ISO 7/1-R 3/4 Thread
3-2724-HF-10	159 001 771	Flat, HF Resistant ¹	3/4 in. NPT, Thread
3-2724-HF-11	159 001 772	Flat, pH Resistant ¹	ISO 7/1-R 3/4 Thread
3-2726-10	159 001 555	Bulb	¾ in. MNPT, Thread
3-2726-11	159 001 556	Bulb	ISO 7/1-R 3/4 Thread
3-2726-HF-10	159 001 551	Bulb HF Resistant ¹	¾ in. MNPT, Thread
3-2726-HF-11	159 001 552	Bulb HF Resistant ¹	ISO 7/1-R 3/4 Thread
3-2726-LC-10	159 001 559	Bulb, Low Conductivity ²	¾ in. MNPT, Thread
3-2726-LC-11	159 001 560	Bulb, Low Conductivity ²	ISO 7/1-R 3/4 Thread
ORP Electrodes; Compatible with the 2751 pH/ORP Smart Sensor Electronics*			
3-2725-60	159 001 561	Flat	¾ in. MNPT, Thread
3-2725-61	159 001 562	Flat	ISO 7/1-R 3/4 Thread

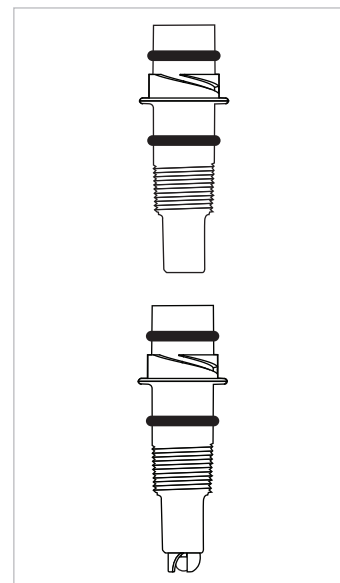

i The 3 KΩ Balco temperature element electrodes are compatible with the 2751 pH/ORP Smart Sensor Electronics, 9900 and 9950 instruments.

* The 2751 pH/ORP Smart Sensor Electronics has a digital (S³L) output which is used with 9900 or 9950 instruments, and the Profibus Concentrator. It also has a 4 to 20 mA output for connections to PLC's, data recorders, etc.

¹ HF resistant ≤2%HF

² Low conductivity applications, 20 - 100 μS/cm recommended

Accessories and Replacement Parts

Mfr. Part No.	Code	Description
1220-0021	198 801 000	O-ring, FKM (2 required per sensor)
3-2700.395	159 001 605	Calibration kit: includes 3 polypropylene cups, box used as cup stand, 1 pint pH 4.01, 1 pint pH 7.00
3822-7115	159 001 606	20 gm bottle quinhydrone for ORP calibration (must use pH 4.01 and/or pH 7.00 buffer solutions)
3-2759	159 000 762	pH/ORP System Tester (adapter cable sold separately)
3-2759.391	159 000 764	2759 DryLoc adapter cable (for use with 2751)
3-0700.390	198 864 403	pH Buffer Kit (1 each 4, 7, 10 pH buffer in powder form, makes 50 ml of each)
3822-7004	159 001 581	pH 4.01 buffer solution, 1 pint (473 ml) bottle
3822-7007	159 001 582	pH 7.00 buffer solution, 1 pint (473 ml) bottle
3822-7010	159 001 583	pH 10.00 buffer solution, 1 pint (473 ml) bottle
3800-5000	159 838 107	3.0M KCl storage solution for pH and ORP, 1 pint (473 ml) bottle
3-2700.397	159 001 870	Protective cap for pH/ORP electrodes, 5 pieces
3-2700.398	159 001 886	O-ring lubricant Kit (5 packs of Super Lube®, 1cc each)