

3-Way heavy duty flow control, with pressure compensated and solenoid controlled priority flow

A-VRFC3C-VEI-VS

0M.43.20.80 - Y - Z

RE 18309-53

Edition: 11.2023

Replaces: 01.2023

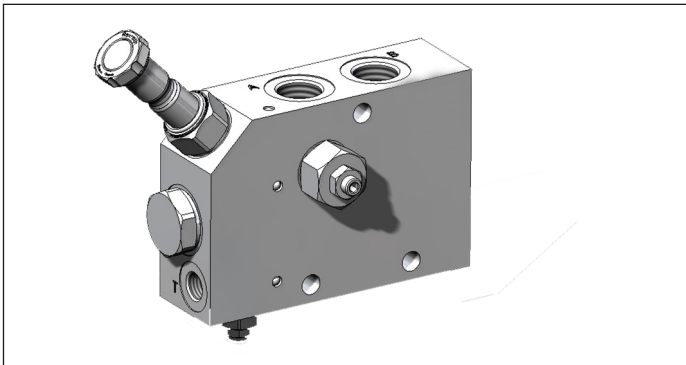

Description

The flow control valves series “A-VRFC3C-VEI-VS” are 3 way, with one inlet “P” and two outlets “A” and “B”, the first outlet “A” being priority, pressure compensated type, with pressure relief valve and available on demand through a solenoid cartridge; the second outlet “B” is the by-pass for all flow in excess of what demanded by priority. Both flows from “A” and “B” ports can be employed to power different functions of the machine. These valves provide a simple and efficient way to power hydraulic tools (such as hydraulic hammers) from the existing hydraulic system, without any need to modify the directional control valve. They allow the simultaneous operations, independently from the respective working pressures, of both the hydraulic actuator powered by the priority outlet “A”, and of the normal functions of the machine (traction, slewing, cylinder motions, etc.) supplied by the main directional valve through the by-pass outlet “B”.

Technical data

Max. operating pressure	350 bar (5000 psi)
Max. priority line pressure: limited by relief valve (6). See “priority pressure range”	
Back pressure at T port	max. 1.5 bar (20 psi)
Drain from T, with solenoid valve non-energized	up to 1.5 l/min. (0.4 gpm)
Weight	See “Dimensions”
Manifold material	Zinc plated steel
Fluid	Mineral oil (HL, HLP) according to DIN 51524
Fluid temperature range	-20 °C to 80 (-4 to 176 °F)
Viscosity range	20 to 380 mm ² /s (cSt)
Recommended degree of fluid contamination	Class 19/17/14 according to ISO 4406
Other technical data	see data sheet 18350-50

Note: for applications outside these parameters, please consult us.

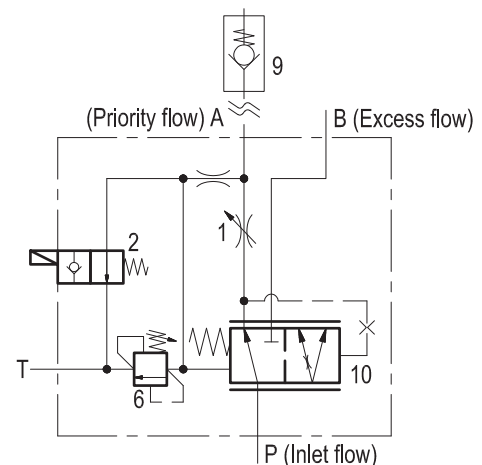

Ordering code

0M.43.20.80	Y	Z
--------------------	----------	----------

3-Way heavy duty flow control, with pressure compensated and solenoid controlled priority flow

Priority pressure range			
	Adj. pressure range bar (psi)	Pres. increase bar/turn (psi/turn)	Std. setting Q=5 (l/min.) bar (psi)
= 20	200-350 (2900-5000)	167 (2422)	200 (2900)
= 35	350-460 (5000-6670)	228 (3306)	350 (5000)

	Port sizes		Inlet flow (max)		Regulated priority flow	
	P-A-B	T	l/min (gpm)	l/min (gpm) max	l/min (gpm) per turn	
= 03	G 1/2	G 1/4	100 (26)	85 (23)	approx. 18 (4.8)	
= 04	G 3/4	G 1/4	200 (53)	140 (37)	approx. 20 (5.3)	
= 05	G 1	G 1/4	300 (79)	220 (58)	approx. 26 (6.9)	
= 06	G 1-1/4	G 1/4	400 (106)	300 (80)	approx. 28 (7.4)	

Note: the spare part is delivered with a different setting from the setting of the cartridges used in the block; please refer to cartridge valves datasheet for standard setting data and bar adjustment for each turn of the screw.

Tamper resistant cap
ordering code 11.04.31.001
Mat. no. R930000777



Preferred types

Type	Material number
0M432080032000D	R930067636
0M432080033500D	R930067646
0M432080042000E	R930067629
0M432080043500A	R930067635
0M432080052000E	R930069295
0M432080053500B	R930069296
0M432080062000E	R930069297

Type	Material number
0M432080063500A	R930069298

Characteristic curves

Priority flow vs pressure **By-pass line pressure drop**

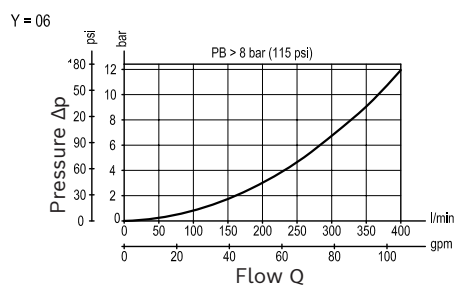
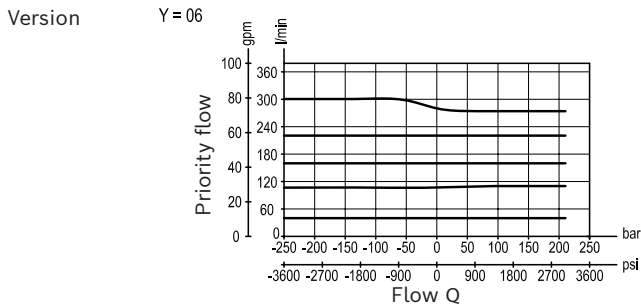
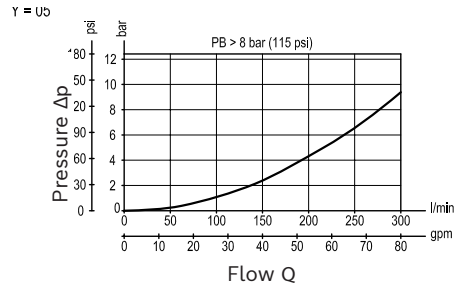
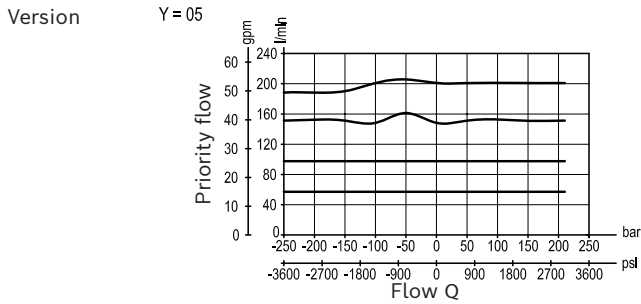
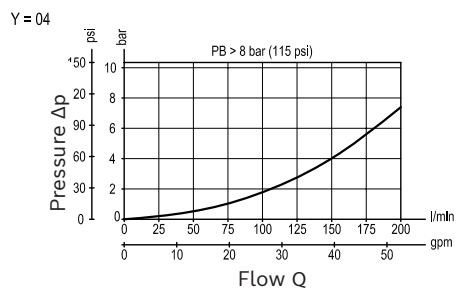
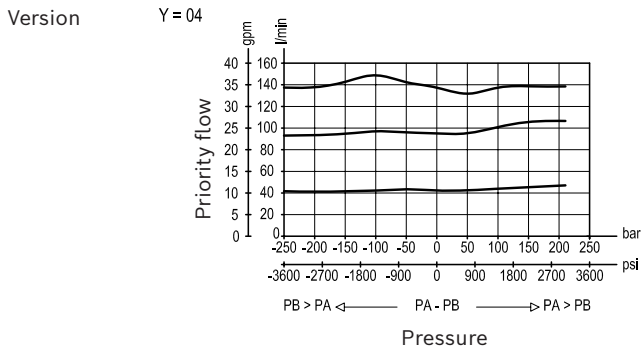
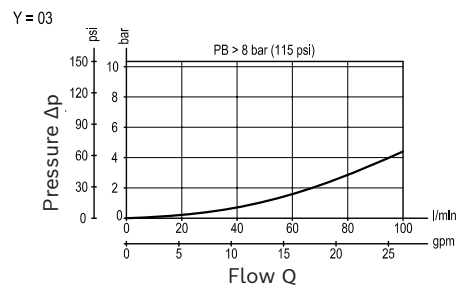
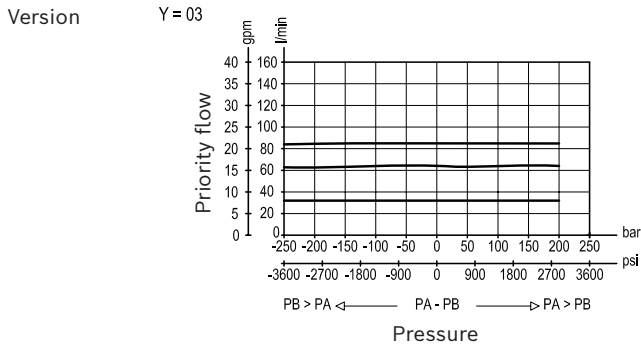

Dimensions

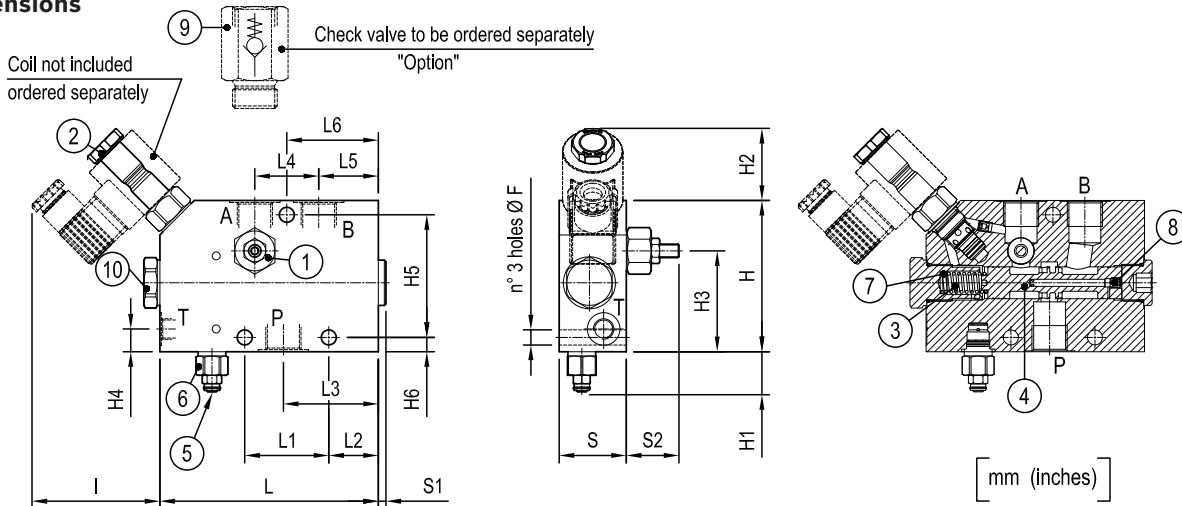

32 (1.26)	5 (0.2)	70 (2.76)	86 (3.39)	54.5 (2.15)	62.5 (2.46)	88.5 (3.48)	48 (1.89)	76 (2.99)	190 (7.48)		18 (0.71)	90 (3.54)	14 (0.55)	92 (3.62)		25.5 (1)	130 (5.12)	9 (0.35)	G 1-1/4	12.5 (27.5)
32 (1.26)	5 (0.2)	60 (2.36)	74.5 (2.93)	46.5 (1.83)	56.5 (2.22)	78 (3.07)	36.5 (1.44)	76 (2.99)	173 (6.81)		15 (0.59)	90 (3.54)	13.5 (0.53)	80.5 (3.17)		24 (0.94)	120 (4.72)	9 (0.35)	G 1	9 (19.8)
32 (1.26)	5 (0.2)	50 (1.97)	59 (2.32)	37 (1.46)	44 (1.73)	61 (2.4)	34 (1.34)	50 (1.97)	140 (5.51)	78 (3.07)	13.5 (0.53)	73 (2.87)	13 (0.51)	69.5 (2.74)	42 (1.65)	25.5 (1)	100 (3.94)	9 (0.35)	G 3/4	4.8 (10.6)
32 (1.26)	5 (0.2)	40 (1.58)	54.5 (2.15)	35.5 (1.4)	38 (1.5)	56.5 (2.22)	29.5 (1.16)	50 (1.97)	130 (5.12)	76 (2.99)	8.5 (0.34)	73 (2.87)	12.5 (0.49)	60 (2.36)	43 (1.69)	24 (0.94)	90 (3.54)	8.5 (0.34)	G 1/2	3.4 (7.5)
S2	S1	S	L6	L5	L4	L3	L2	L1	L	I	H6	H5	H4	H3	H2	H1	H	F	Port sizes	Weight kg (lbs)

Fitting and connections

When positioning and tightening the valve, avoid any deflection of the body which could prevent the internal spool from sliding freely and impair the metering performance; it is recommended to use the 3 available fixation holes as locating points and to fit 3 equal spacers (metal washers), one on each point, between the valve body and the supporting structure.

Connections to the hydraulic system:

- Port “P” (inlet) to the main line from the pump.
- Port “A” (priority outlet) to the line feeding the hydraulic hammer, or the attachment. Important: for the correct metering of the compensating spool the priority outlet shall be always pressurized, with a back-pressure of at least 8-9 bar (115-130 psi); if necessary, fit a check valve with the needed cracking pressure.
- Port “B” (by-pass, or excess flow outlet) to the line delivering the oil to the main directional valve.
- Port “T” to a tank line. It is absolutely necessary that port “T” is connected to a low pressure tank line, 1-1.5 bar max (15-22 psi max).

Sleeve type check valves

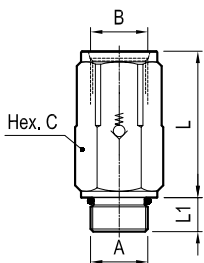

Port sizes A - B	Cracking pressure bar (psi)	Dimensions mm (inches)			Ordering code
		C	L	L1	
G 1/2	8 (115)	30 (1.18)	57 (2.24)	14 (0.55)	043117000301000 R930000444
G 3/4	8 (115)	36 (1.42)	69 (2.72)	16 (0.63)	043117000401000 R930000445
G 1	8 (115)	46 (1.81)	82 (3.23)	18 (0.71)	043117000501000 R930000446
G 1 1/4	8 (115)	55 (2.17)	102 (4.02)	20 (0.79)	043117000601000 R930000447

Adjustment of priority flow

The volume of priority flow from port “A” can be easily modified by turning the screw (1): the flow increases by turning the screw clockwise and, once adjusted to the desired level, it remains constant independently from the working pressure.

Adjustment of maximum priority pressure

The maximum pressure in the priority line “A” can be adjusted by turning the screw (5) of the small relief cartridge (6) which controls the maximum pressure in the chamber (3): when this “pilot” cartridge opens, the pressure in chamber (3) drops and the priority flow is stopped. Note: the relief cartridge (6) controls only the maximum pressure in the priority outlet “A”, and does not control the pressure in the by-pass and main line: the main line must be protected by another relief valve, capable to discharge the full oil flow.

COILS

Ordering code: **OD.02.36 - X - Y - Z**

Attention: indicated coils fit every hammer valve versions

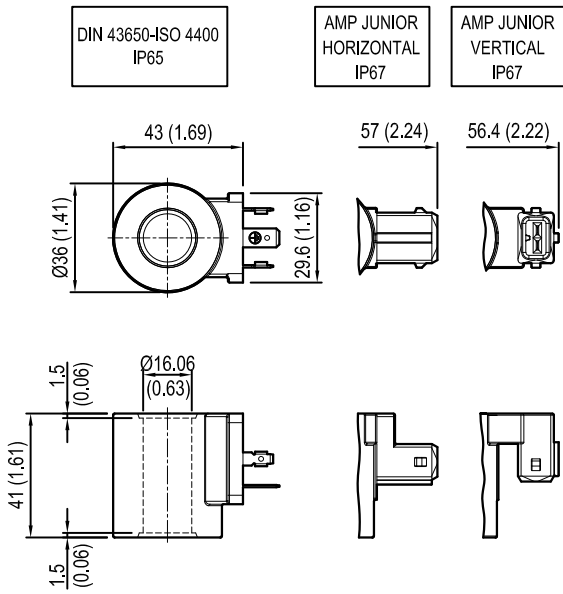

TECHNICAL DATA
 Weight: 0.18 kg (0.40 lbs)
 Power: 20 W
 Heat insulation Class H: 180°C (356°F)
 Ambient temperature range: -30/+90°C (-22/+194°F)
 Further performance limits in terms of temperature and voltage fluctuations: please refer to data sheet of the solenoid valve where D36 coil is mounted.

X	Y	Connections	Circuit	Voltage
01	30	DIN 43650 - ISO 4400	Standard	DC
07	30	AMP JUNIOR H	Standard	DC
07	3P	AMP JUNIOR V	Standard	DC
14	30	DIN 43650 - ISO 4400	Bidirectional Diode	DC
15	30	AMP JUNIOR H	Bidirectional Diode	DC
15	3P	AMP JUNIOR V	Bidirectional Diode	DC

[mm / Inches]

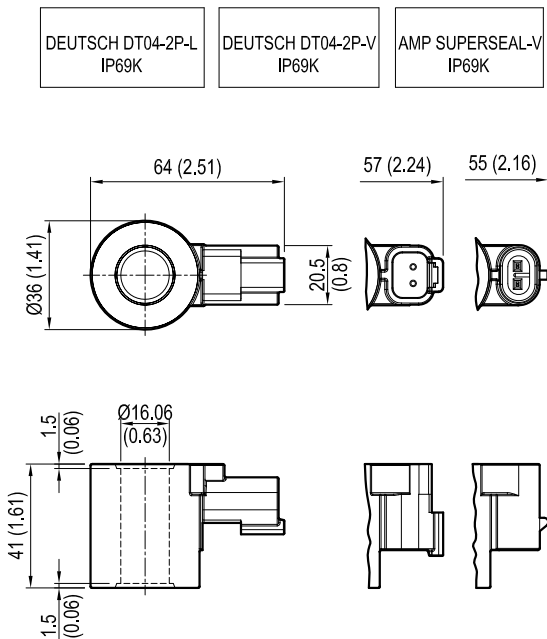

X	Y	Connections	Circuit	Voltage
20	30	DEUTSCH DT04-2P-L	Standard	DC
20	3P	DEUTSCH DT04-2P-V	Standard	DC
30	3P	AMP SUPERSEAL-V	Standard	DC
22	30	DEUTSCH DT04-2P-L	Bidirectional Diode	DC
22	3P	DEUTSCH DT04-2P-V	Bidirectional Diode	DC
32	3P	AMP SUPERSEAL-V	Bidirectional Diode	DC

[mm / Inches]

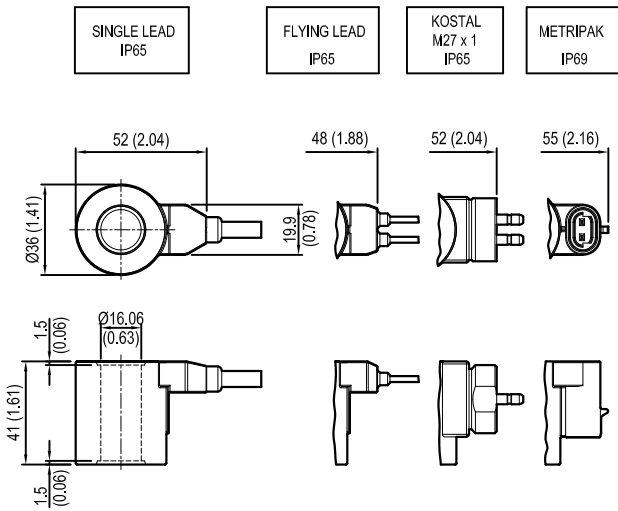

[mm / Inches]

X	Y	Connections	Circuit	Voltage
0G	03	SINGLE LEAD *	Standard	DC
02	03	FLYING LEAD **	Standard	DC
03	30	KOSTAL M27x01	Standard	DC
40	3P	METRIPAK	Standard	DC
0H	03	SINGLE LEAD *	Bidirectional Diode	DC
23	03	FLYING LEAD **	Bidirectional Diode	DC
12	30	KOSTAL M27x01	Bidirectional Diode	DC
41	3P	METRIPAK	Bidirectional Diode	DC

* Length 300mm (11.8 inches). Ext. diameter 6.3mm (0.25 inches). External and internal Sheath Silicone rubber.
 ** Length 300mm

Note: Single lead and Flying lead coil also available with 1000 mm length; ordering code with Y=10 in place of Y=03

Z	Voltage V	Resistance Ohm (±7%)	Power W	Current A	
	Nominal	aT = 20 °C (68 °F)		I Max.	I Nom.
OB	12 DC	7.4	20	1.67	1.04
OC	24 DC	28.4	20	0.83	0.54
OD	48 DC	106.5	20	0.42	0.29
OU*	96 DC	451	20	0.21	0.14
AH*	205 DC	2062	20	0.10	0.06

* OU and AH versions especially designed in cases of AC supply voltage (respectively for 110AC and 220 AC) to be used in conjunction with connector with circuit including wave rectifier. Ambient temperature range for OU and AH versions: -30°C / + 75°C

Note: diode available only for 12 V DC and 24 V DC coils. Diode set at 27 V DC for 12 V DC coil and at 39 V DC for 24 V DC coil.

Note: please refer to data sheet RE 18325-90 for coils and connectors readily available and for further details.

SPARE PARTS

SOLENOID CARTRIDGE	
Port size	Ordering code
0M.43.20.80.03.20	OD150218A000000 R930059442
0M.43.20.80.03.35	
0M.43.20.80.04.20	
0M.43.20.80.04.35	
0M.43.20.80.05.20	
0M.43.20.80.05.35	
0M.43.20.80.06.20	
0M.43.20.80.06.35	

RELIEF CARTRIDGE	
Port size	Ordering code
0M.43.20.80.03.20	041158039946000 R901098895
0M.43.20.80.04.20	
0M.43.20.80.05.20	
0M.43.20.80.06.20	041158039935000 R901113597
0M.43.20.80.03.35	
0M.43.20.80.04.35	
0M.43.20.80.05.35	
0M.43.20.80.06.35	