

Standard Features:

- Dual Isolated Outputs (Can be Different Types)
- High Input-Output-Power Isolation (2000 VAC Test for 1 second)
- Low Input Impedance on 4-20mA Inputs
- Small Size - Fits on Terminal Block Rail
- Industry Standard Inputs and Outputs (see back)
- High Output Drive (1000 Ohms for 4-20 mA)
- Two Wire Supply Option for Two Wire Transmitters
- Power: 24 VDC, 120-190 mA
- High Noise Rejection
- CSA Certification 2054910



Pollution Degree 2

Installation Category II

Do Not Expose To Direct Sunlight

The ITC-XXX is a dual signal isolator that provides high isolation from Input to Output1 to Output2 to Power in a small, easy to install package. The universal DIN rail mount often makes it possible to install the ITC-XXX right next to the instrument that is to be isolated. The many different input and output configurations allow it to be used in a great variety of applications ranging from PLC front end conditioning to adding an extra loop with lots of drive to an existing, almost fully loaded, loop.

The high output drive (1000 Ohms @ 4-20 mA for each output) allows the ITC-XXX to drive several other instruments directly from either of its outputs. The standard two wire supply allows the ITC-XXX to be used with two wire field transmitters such as differential pressure transducers, temperature sensors, etc. Both outputs can be of a different type to provide maximum flexibility in system designs.

If the equipment is used in a manner not specified by the manufacturer, the protection provided by the equipment may be impaired

Specifications:

	ITC-XXX	ITC-SLXXX	ITC-MVXXX	ITC-TXXXX
Power ¹⁾	12VDC 24VDC 40VDC	250mA, 390mA max. 120mA, 190mA max. 75mA, 120mA max.	255mA max. 122mA max. 76mA max.	250mA max. 120mA max. 75mA max.
Isolation	High Input to Output1 to Output2 to Power (2000 VAC Test for 1 second)			
Input Impedance	see Input table	10 Meg Ohm	10 Meg Ohm	10 Meg Ohm
Accuracy / Linearity	± 0.2% max., ± 0.1% typ.	± 0.2% max., ± 0.1% typ.	± 0.3% max., Drift 1µV/°C	Linear with Material ± 2°C
Loop Res. D Effect	-0.1% per 100 Ohms change			
Common Mode Rej.	at 60 Hz = 120 dB			
Response Time	50 msec to 63%	75 msec to 63%	100 msec to 63%	100 msec to 63%
Drift at 25 Deg.C	24 Hours: ± 0.03%, 30 Days: ± 0.1%		24 Hours: ± 0.3%, 30 Days: ± 0.8%	
Operating Temp.	-40 °C. to + 50 °C.			
Environment	Altitude: 0-6562 ft (0-2000 m) Humidity: 0-95% RH non-condensing			

¹⁾ CAUTION To be powered by a class 2 source.

(Maximum Signal Input 30VAC or 60VDC or 5Amps) (Maximum Signal Output 30VDC or 50mA)

ITC-XXX-XX-DC

Connection:

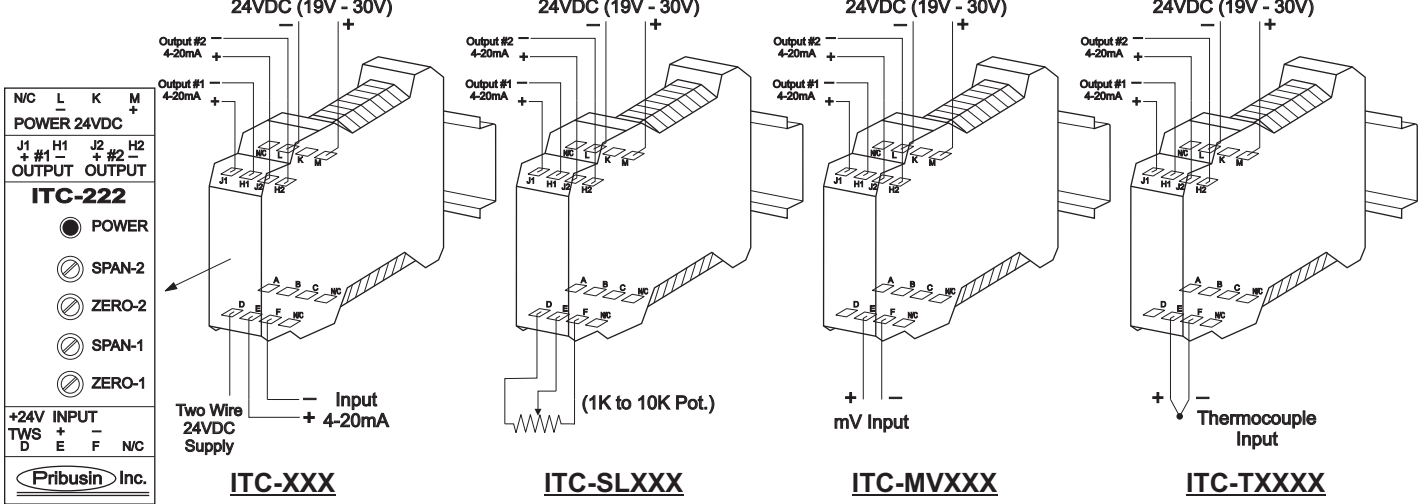

Model Designation:

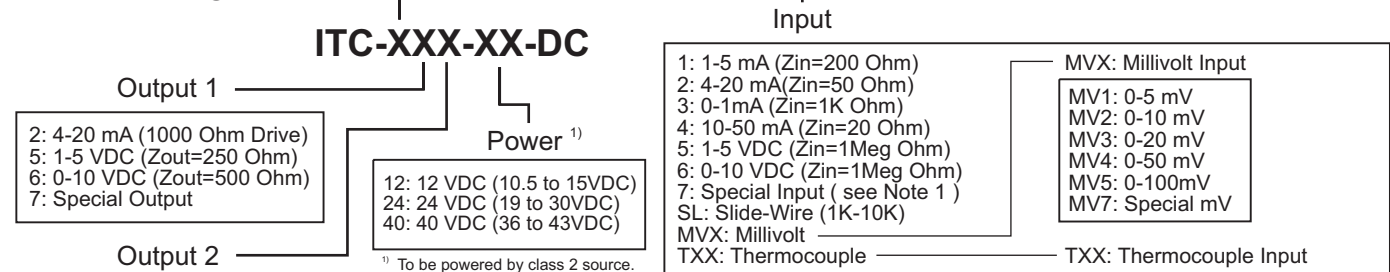

Model Designation Examples:

1. Isolator with 4-20mA input, 4-20mA output and 0-10VDC output, powered by 24VDC is: **ITC-226-24-DC**
2. Isolator with 0-50mV input and two 0-10VDC outputs, powered by 12VDC is: **ITC-MV466-12-DC**
3. Isolator with type 'K' thermocouple input for 0-750°F and two 4-20mA outputs, powered by 24VDC is: **ITC-TK322-24-DC**

Range	Type	J	K	E	T	R	S
0 to 300F -18 to 150C	TJ1			TE1	TT1		
0 to 400F -18 to 204C	TJ2	TK1		TE2	TT2		
0 to 500F -18 to 260C	TJ3	TK2		TE3	TT3		
0 to 750F -18 to 400C	TJ4	TK3		TE4		TR1	TS1
0 to 1000F -18 to 538C	TJ5	TK4				TR2	TS2
0 to 1500F -18 to 816C		TK5				TR3	TS3
0 to 2000F -18 to 1093C		TK6				TR4	TS4
0 to 3200F -18 to 1760C						TR5	TS5
-350 to 1100F -200 to 600C	TJ6			TE5			

Dimensions:

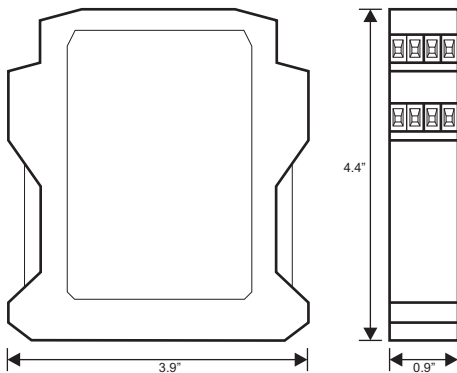

(Note 1. Maximum Signal Input 30VAC or 60VDC or 5Amps)