



ROTARY PISTON PUMPS

THE FEED PUMP TYPE SKK

The variants of the feed pump SKK

Type SKK

- rotation-independent
- safe to run dry (no metal contact)
- sturdy construction with one-sided bearing
- power transmission gears in the oil bath
- additional bearing in the cover for higher pressures
- several sealing types
- easy assembly
- several types of pipe connections

Type SKKM

- casing with cover heating
- entirely closed heater jacket
- any heating with water, steam or oil is possible
- heating circuit-pressure max. 6 - 8 bar
- heating temperature up to 200 °C (standard), higher temperatures on request

Type SKKE

- electrical cover heating
- heatable by 2 heating cartridges
- temperature controlled
- adjustable up to 200 °C (standard), higher temperatures on request

Feed pump SKK

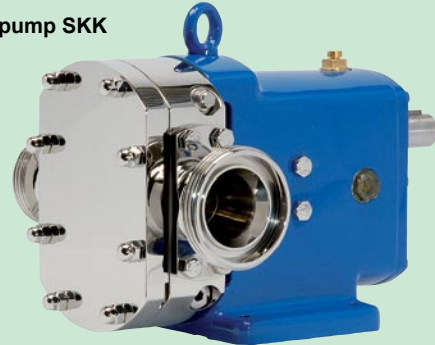

Feed pump SKKM

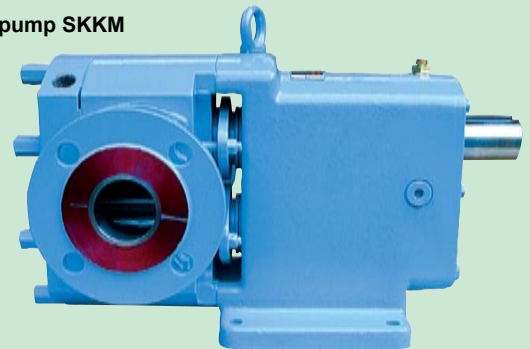

Feed pump SKKE

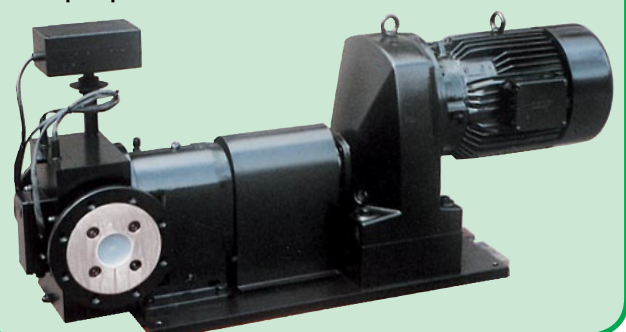

Range of pumping liquids (extr.)

Biotechnology

Cell suspensions, enzymes, nutrient solutions

Chemistry

Adhesives, artificial resin solutions, colours, dispersed synthetic resin, gelatine, lacquers, underseal, washing powder slurries

Beverage industry

Advocaat, beer mash, fruit concentrates, malt extract, syrup, yeast

Milk products

Butter, cheese curd, cream, margarine, mayonnaise, concentrates of milk, skimmed milk and whey, pudding, processed cheese, yoghurt

Food

Apple purée, aspic, baby food, blood, cake mixtures, egg products, animal and vegetable fat, honey, jam, mustard, salads, sauces, sausage meat, soups, tomato ketchup

Petrochemistry

Additives, bio diesel, bitumen with fillers, diesel oil, glyzerine, lubricants, mineral and synthetic oils, pitch, pure bitumen

Pharmaceuticals / cosmetics

Cremes, foam bath, make-up, lotions, plant extracts, ointments, shampoo, toothpaste

Sugar / Sweets

Chocolate, chocolate fillings, cocoa butter, cocoa mass, fondant, jam, liquid sugar, liquorize, mass for sweets, molasses, starch solution, toffee

Reference technical data

Feeding capacity 60 - 1.700 cm³ / turn

Tolerated overpressure depending on the application up to max. 20 bar

Viscosity range depending on the application up to 100.000 mm²/s

Main characteristics

The series of the types SKK offers a wide range of different variations and constructions for the **transport of nearly all pumpable media**.

The pump consists of the gear component with synchronous drive of the two rotary pistons and the part of the pump containing the casing with suction and pressure joint and the two rotary pistons.

The sturdy bearing is located in the gear component, protected against the pumping liquid by different seals. On the other hand, special seals prevent any leaking of the transmission lubricant out of the gear component.

Since the pistons and the walls in the pump rooms must not touch each other in a rotary piston pump, a slight slipping cannot be avoided. However, it only shows when products of low viscosity (e.g. water) are pumped against pressure. In this case the lower speed range cannot be used.

Products having a viscosity of more than approx. 300 mm²/s (cSt) hardly show any slipping. The volumetric efficiency for these products is nearly 100%.

The suction capacity of the SKK pump very much depends on the viscosity and the speed. The suction capacity of the filled pump works against a water column of at least 8 m, a vacuum of approx. 100 mbar respectively.

It is easy to clean and to maintain. All parts of the pump have easy access for inspection and cleaning once the nuts have been unscrewed and the cover has been taken off. The pipe connections do not have to be removed.

If products are pumped that do not stick or become hardened, it is sufficient to rinse the rotary piston pump well with water or any suitable solvent. Thus the pumps clean itself.

If the pump is used in the food industry, in the pharmaceutical and the cosmetics' industries, the rotary piston pump SKK has a special construction so that it can be dismantled quickly. Thus all parts coming into contact with the product (casing, pump, etc.), as well as the sealing parts can be easily reached for cleaning. There are no dead corners, uncontrollable pits etc. The pump can also be sterilized by blowing steam through it.

SKK illustrations

Explosion type of a SKK3 with different flanged ports

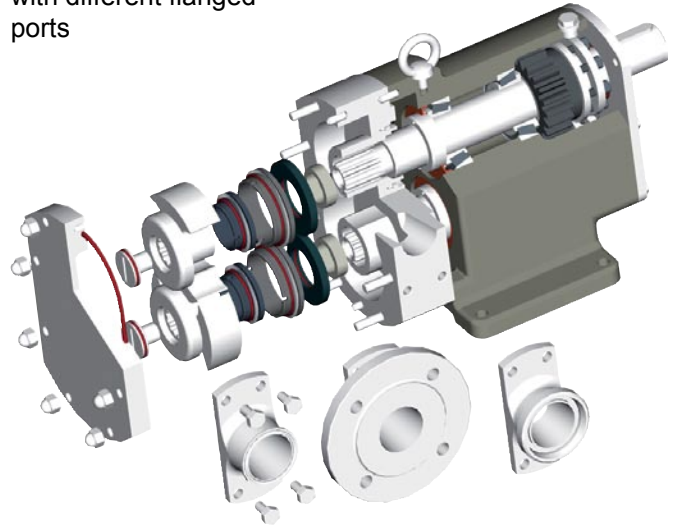

SKK3 in stainless steel with recipient of natural glass, open cover and detached pistons made of bronze



Use in the ATEX range



We deliver rotary piston pumps according to **EC Guideline 94/9/EC**.

Zone 1 + 21 (II 2 G / D T3 and T4) units, which assure a high level of security. Designed for the use in an atmosphere that is potentially explosive. **Shaft seal (G + GG) without temperature control**.

Zone 2 + 22 (II 3 G / D T3) units, which assure a normal level of security. Designed for use in atmospheres that rather seldom and if so, only shortly might be potentially explosive. **Shaft seal (P, G + SS) without temperature control**.

Variants of pistons and covers

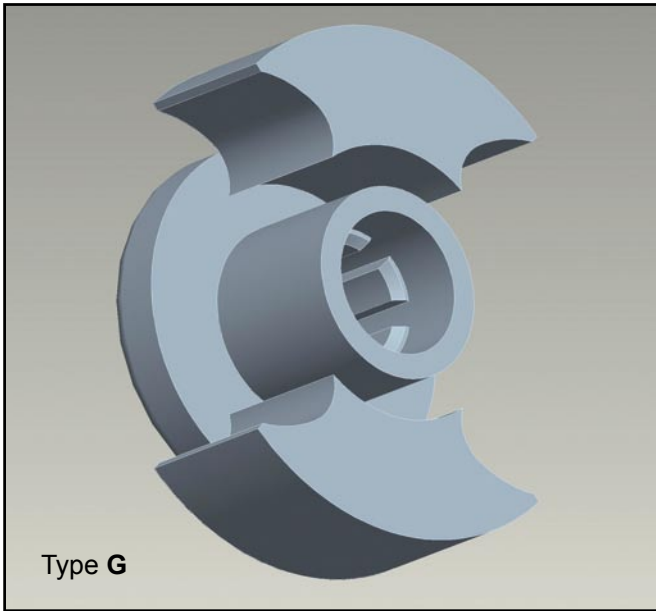

The **open piston type G** is used for media of low viscosity in combination with the shaft seals G and GG.

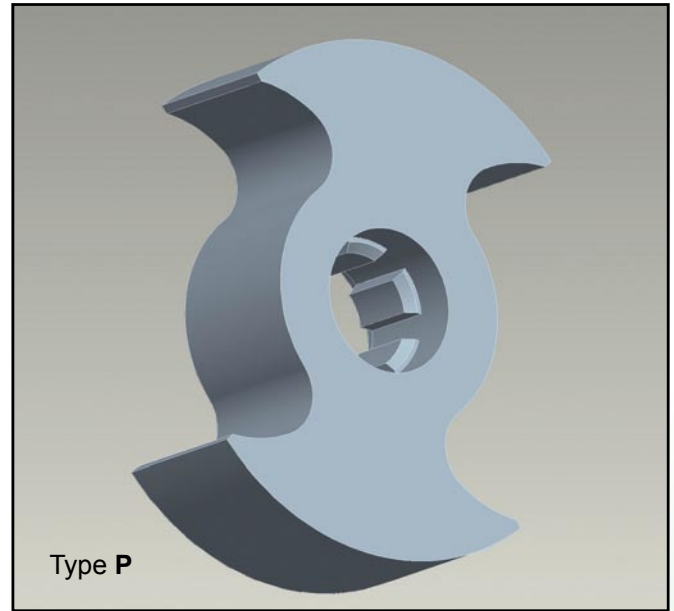

The **closed piston type P** is used for media of higher viscosity in combination with the shaft seals P and SS.



Recipients



Recipient (unpressurized) made of natural glass



Stainless steel-recipient to be pressurized, conform to ATEX



Stainless steel-recipient to be pressurized with float switch, conform to ATEX



Thermosiphon system to be pressurized with cooling spiral and back-feed pump, conform to ATEX

Survey of structural components

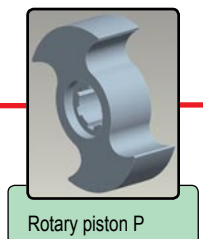
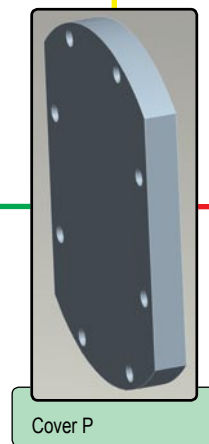
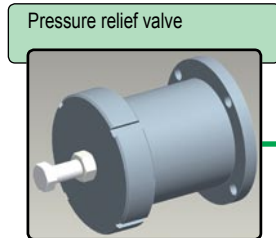
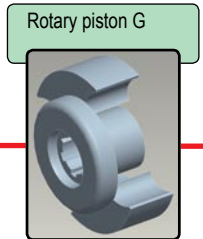
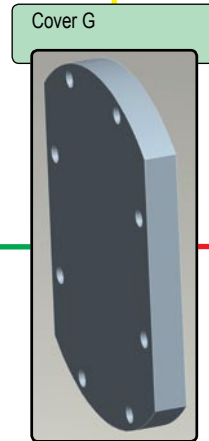
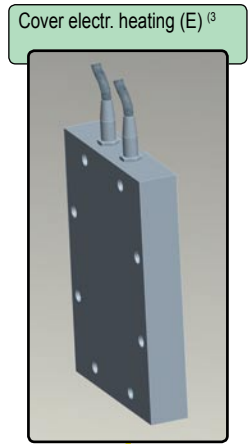
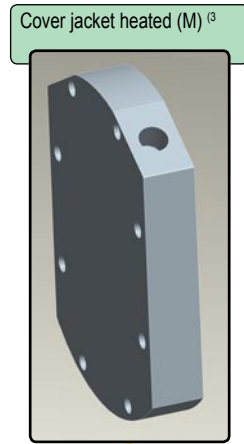
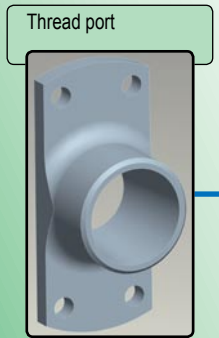
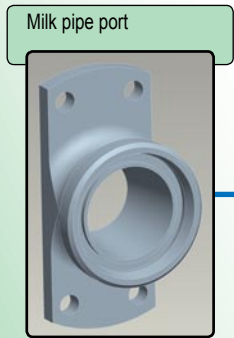
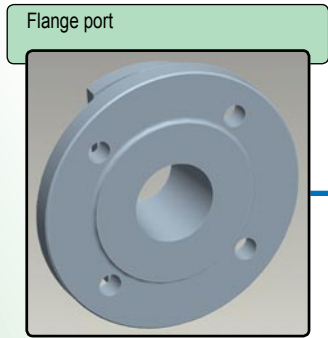
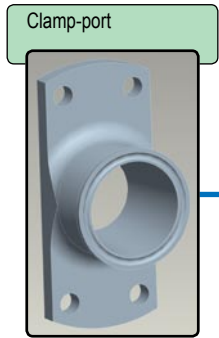

- Main structural components of the pump
- Connection variants at the pressure and suction port
- Optional structural components
- Optional, heatable covers

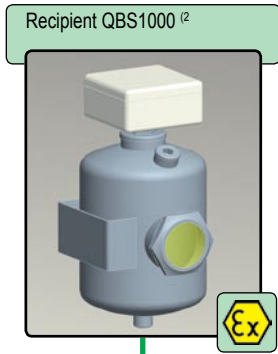
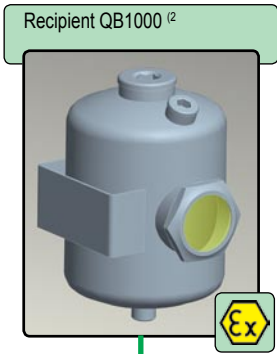

The parts of the SKK pump shown in the survey of structural components shall illustrate the great amount of variants available for this pump type.

For reasons of clarity we cannot show all optional structural components. We only show the main parts here. Besides these variants, we offer casings, pistons and covers in different materials, offering further possibilities of combination.

Gebr. Steimel is your partner for individual solutions. Please contact us without any obligation, if you need further information concerning the standard components or are interested in a special variant that is not shown here and that is adapted to your needs.

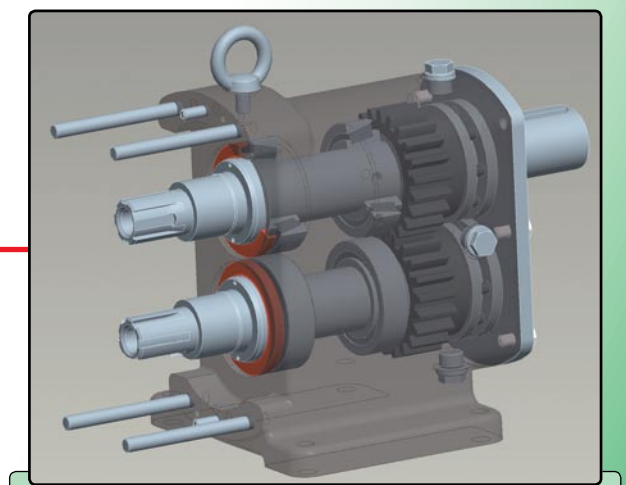
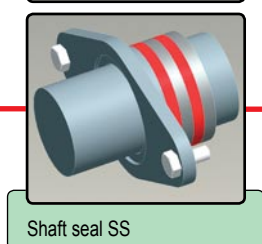
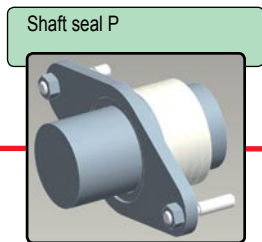
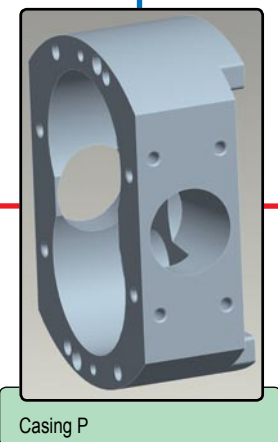
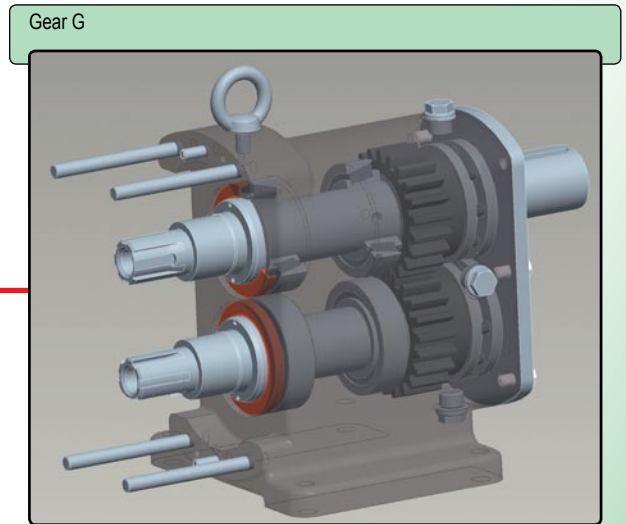
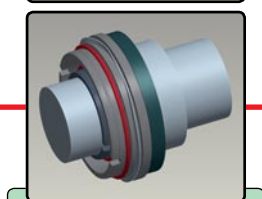
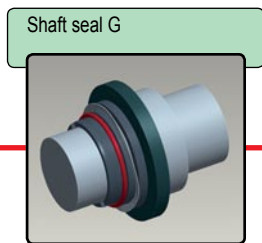
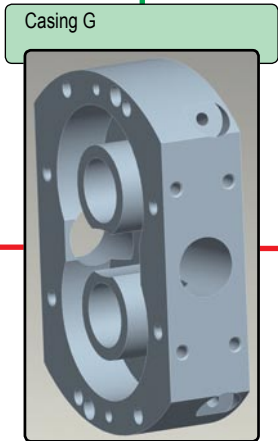

⁽¹⁾ If you do not find your connection here, please contact us!
⁽²⁾ Recipient for quench liquid acc. to ATEX. The thermosiphon system that is also available is not shown here.
⁽³⁾ The heatable covers that are available as an alternative to the standard covers are available as G and P variants.

Throughputs

Size	Pump rate	Pressure p (bar) at speed n = 200 1/min				Pressure p (bar) at speed n = 400 1/min				Throughputs cm ³ /turn
	Power rating	2	4	6	8	2	4	6	8	
SKK 3/0060	l/min	11	10	9	8	24	23	22	21	60
	NkW	0,2	0,24	0,3	0,36	0,26	0,36	0,44	0,53	
	kW	0,25	0,37	0,37	0,55	0,37	0,55	0,55	0,75	
SKK 3/0105	l/min	20	18	17	16	41	39	37	36	105
	NkW	0,25	0,34	0,42	0,5	0,5	0,64	0,77	1,1	
	kW	0,37	0,55	0,55	0,75	0,75	0,75	1,1	1,5	
SKK 3/0210	l/min	38	34	29	24	82	77	73	67	210
	NkW	0,48	0,62	0,75	0,9	1,0	1,2	1,5	1,8	
	kW	0,75	0,75	1,1	1,1	1,5	1,5	2,2	2,2	
SKK 4/0250	l/min	49	48	47	45	101	100	98	96	250
	NkW	0,7	0,8	1,1	1,3	1,4	1,7	2,0	2,4	
	kW	1,1	1,1	1,5	2,2	2,2	2,2	2,2	3,0	
SKK 4/0350	l/min	72	70	68	66	143	141	139	137	350
	NkW	0,9	1,1	1,3	1,6	1,4	2,1	2,8	3,4	
	kW	1,1	1,5	2,2	2,2	2,2	3,0	4,0	5,5	
SKK 4/0500	l/min	102	100	98	96	204	202	200	198	500
	NkW	1,4	1,7	2,0	2,4	2,0	2,9	3,7	4,5	
	kW	2,2	2,2	3,0	3,0	3,0	4,0	5,5	5,5	
SKK 5/0850	l/min	178	170	165	158	355	345	340	330	850
	NkW	1,8	2,5	3,2	4,0	3,7	5,0	6,3	7,6	
	kW	2,2	3,0	4,0	5,5	5,5	7,5	7,5	11,0	
SKK 5/1700	l/min	360	355	350	330	726	720	710	695	1700
	NkW	3,8	5,2	6,5	7,8	7,5	9,7	12,0	14,2	
	kW	5,5	7,5	7,5	11,0	11,0	11,0	15,0	18,5	

Size	Pump rate	Pressure p (bar) at speed n = 600 1/min				Pressure p (bar) at speed n = 800 1/min				Throughputs cm ³ /turn
	Power rating	2	4	6	8	2	4	6	8	
SKK 3/0060	l/min	36	35	34	33	50	48	47	46	60
	NkW	0,48	0,63	0,8	1,1	0,7	0,8	1,1	1,3	
	kW	0,75	0,75	1,1	1,5	1,1	1,1	1,5	2,2	
SKK 3/0105	l/min	60	58	57	54	83	81	79	77	105
	NkW	0,62	0,8	1,0	1,2	1,1	1,3	1,4	1,8	
	kW	0,75	1,1	1,5	1,5	1,5	1,5	1,5	2,2	
SKK 3/0210	l/min	121	115	110	103	162	155	148	139	210
	NkW	1,2	1,6	2,1	2,5	1,6	2,3	3,0	3,6	
	kW	1,5	2,2	3,0	4,0	2,2	3,0	4,0	5,5	
SKK 4/0250	l/min	151	149	147	145	201	199	197	195	250
	NkW	1,6	2,2	2,8	3,5	2,0	2,9	3,7	4,5	
	kW	2,2	3,0	4,0	5,5	3,0	4,0	5,5	5,5	
SKK 4/0350	l/min	212	210	208	206	287	285	283	281	350
	NkW	1,9	2,8	3,7	4,5	2,4	3,4	4,4	5,4	
	kW	3,0	4,0	5,5	5,5	3,0	4,0	5,5	7,5	
SKK 4/0500	l/min	305	303	301	299	409	407	405	403	500
	NkW	2,6	3,7	4,8	5,9	3,5	5,1	6,7	8,4	
	kW	4,0	5,5	7,5	7,5	4,0	5,5	7,5	11,0	
SKK 5/0850	l/min	520	505	490	485					850
	NkW	4,7	6,6	8,5	10,6					
	kW	7,5	11,0	11,0	15,0					
SKK 5/1700	l/min	1060	1050	1040	1025					1700
	NkW	9,9	14,0	18,2	22,3					
	kW	15,0	18,5	22,0	30,0					

NkW = nominal power requirement at the pump shaft for a viscosity of 150 mm²/s.

The pump rate (l/min) applies to 200, 400, 600 and 800 1/min. The throughput for other speeds can be calculated accordingly.

Variation of the delivery flow ±5%.

The pump rate is reduced at a viscosity under 150 mm²/s.

Higher pressures are possible on request.

¹ Necessary driving power (20% additional extra has been observed).

Modifications reserved.

Connections

Standard connection widths for suction and pressure connections	SKK 3/0060	SKK 3/0105	SKK 3/0210	SKK 4/0250	SKK 4/0350	SKK 4/0500	SKK 5/0850	SKK 5/1700
Whitworth-external thread DIN ISO 228-1	G1	G1½	G2	G2	G2½	G2½	G4	G5
Whitworth-inside thread DIN ISO 228-1 (for heater jacket)	G¾	G¾	G¾	G½	G½	G½	G¾	G¾
Milk pipe connection DIN 11 851	DN 25	DN 32	DN 50	DN 50	DN 65	DN 80	DN 100	DN 125
Tri-Clamp-connection ISO 2852 / DIN 32 676	DN 25	DN 32	DN 50	DN 50	DN 65	DN 80	DN 100	DN 125
Flanged port DIN 2633 PN 16	DN 25	DN 32	DN 50	DN 50	DN 65	DN 80	DN 100	DN 125

Versions

Cast	casing parts: shafts: pistons: shaft seal:	grey cast iron or nodular iron case hardening steel tempering steel or zinc-free bronze see shaft seals
Zinc-free bronze	casing parts: shafts: pistons: shaft seal:	zinc-free bronze stainless steel stainless steel or zinc-free bronze see shaft seals
Stainless steel	casing parts: shafts: pistons: shaft seal:	stainless steel stainless steel stainless steel or titanium see shaft seals

Other materials, seals and special designs on request.

Key for variants

Construction types

SKK	standard design
E	elektrical cover heating
M	heater jacket
D	pressure relief valve in the cover
GKM	base plate, coupling, motor
GKGM	base plate, coupling, gear motor

Shaft seals

P	packing
G	mechanical seal (GLRD) with simple effect
GG	mechanical seal with double effect and with recipient for quench liquid or thermosiphon system
SS	special seal

Examples for orders

SKK 5/1700 GGD-GKGM

SKK	pump type
5	size
1700	volume cm ³ /turn
GG	with mechanical seal with double effect
D	with pressure relief valve in the cover
GKGM	base plate, coupling, gear motor

Details in section

Abbreviations see page 7, key for variants.

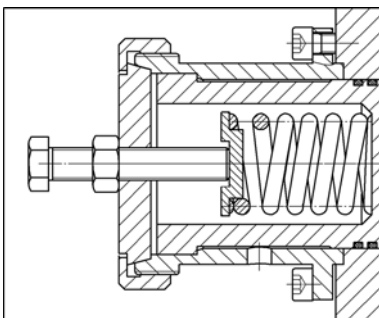

construction **D**
(pressure relief valve)

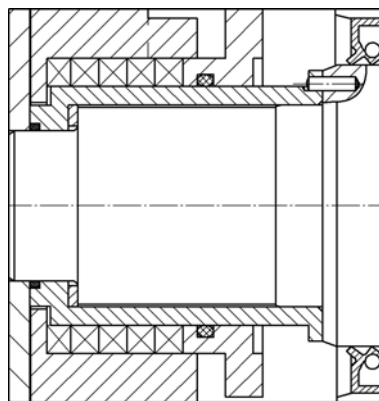

construction **P**

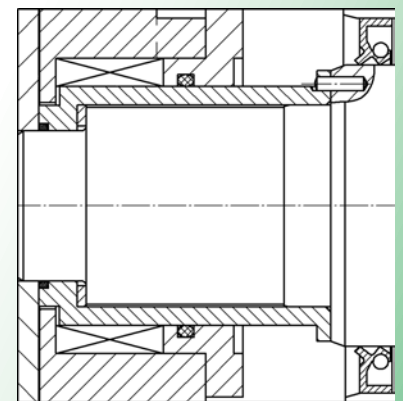

construction **SS**

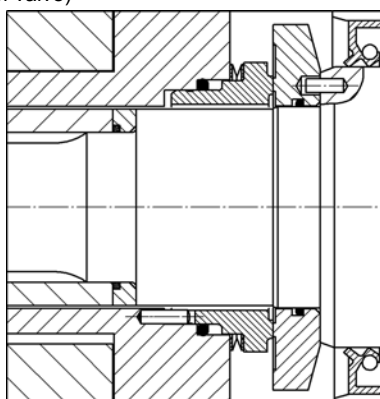

construction **G**

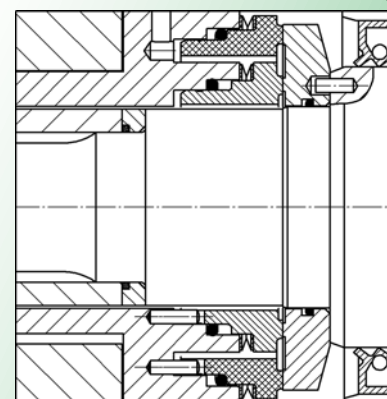

construction **GG**

Examples for types

For the food and chocolate industry

SKK with recipient for quench liquid



chocolate industry



SKK unit for the chocolate industry

e.g. chocolate container with SKK rotary piston pumps



For the colours and lacquers' industry



Compact pump unit SKK with recipient for quench liquid acc. to ATEX

e.g. rotary piston pumps in printing colour plant



For bitumen treatment

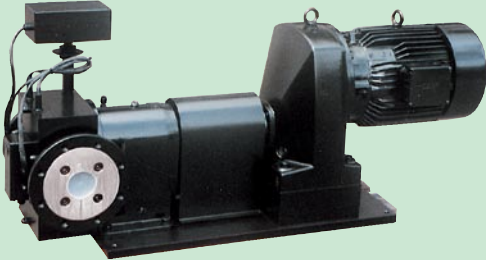

Compact pump unit SKKE with electrical cover heating

e.g. rotary piston pumps for bitumen conveyor and mixing plants



For the chemical, pharmaceutical industry and petrochemistry



e.g. SKK with thermosiphon system acc. to ATEX in a bio diesel plant

Compact pump unit SKK with pressure relief valve and recipient for quench liquid

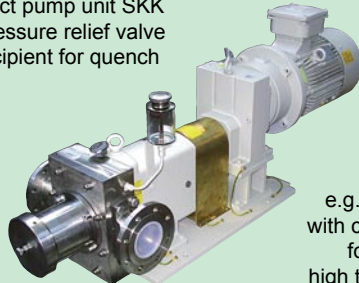

e.g. in acid plant with cooling jacket for media with high temperatures

