



200 SERIES

THREADED VALVES

MECAIR - 200 SERIES

THREADED VALVES

PRODUCT LEAFLET

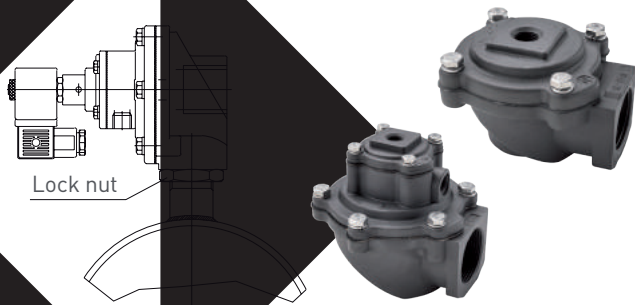

DESCRIPTION

The 200 SERIES is a range of diaphragm valves suitable for dust collector applications, in particular for reverse pulse-jet filter cleaning of filter bags, cartridges, envelope filters, ceramic filters and sintered metal fibre filters. The 200 Series valve has the inlet port at 90° to the outlet port. The 200 Series range comprises 6 models, from 3/4" to 2 1/2", all with threaded female Gas connections. The 1 1/2" model is available in single and double diaphragm versions, while the 2" and 2 1/2" are all double diaphragm valves. The special design assures an extremely fast opening time, high flow rates and easy installation. The valves are constructed in diecast aluminium and have an anodised protection treatment which protect them from corrosive and environmental agents. Bolts and screws are in stainless steel. The 200 Series is available in the following versions:

- **VNP**, with integrated solenoid pilot
- **VEM**, with remote pneumatic connection.

Upon request: Integral pilot valves with ATEX Certification: • ATEX II 3 D (94/9/CE); for the above approved model the correct code to use is VEM+PV 24V/DCX (solenoid coil is 24 V-DC/18 W and DIN connector in conformity with the ATEX Directive 94/9/CE) (PLG11-ATEX). Remote pilot valves meet the requirements of: • ATEX II 2 GD when mounted with PXA Pilot or CXD Enclosure (94/9/CE).

GENERAL CHARACTERISTICS

FLUIDS	Filtered air and oil free
DIAPHRAGM	Standard Nitrile: -20°C/+80°C Optional Viton: -30°C/+200°C
PRESSURE RANGE	From 0.5 to 7.5 bar

CONSTRUCTION FEATURES - VALVE

COVER	Diecast aluminium (anodised)
BODY	Diecast aluminium (anodised)
PILOT BASE	Aluminium (anodised)
PILOT	Stainless steel
DIAPHRAGM	NBR
BOLTS AND SCREWS	Stainless steel
DIAPHRAGM BACKING DISK	Stainless steel
DIAPHRAGM SPRING	Stainless steel

ELECTRICAL CHARACTERISTICS - SOLENOID

COIL INSULATION	Class H
DIN SOCKET CONNECTOR	Pg9 connection (cable entry)
DIN SOCKET STANDARD	EN175301 - 803 (previously DIN 43650A) / A/ISO 4400
DIN SOCKET OPTIONAL	94/9/CE ATEX II 3GD T6
ISOLATION CLASS DIN SOCKET	VDE 0110 - 1/89
ELECTRICAL PROTECTION	IP65 EN60529
VOLTAGE RANGE	12 V DC (supply +10% max.) 18 W 24 V DC (supply +10% max.) 18 W 48 V DC (supply +10% max.) 18 W 110 V DC (supply +10% max.) 18 W 24 V 50/60 Hz (supply +10% max.) 38/31 VA 48 V 50/60 Hz (supply +10% max.) 41/32 VA 115 V 50/60 Hz (supply +10% max.) 63/53 VA 220/240 V 50/60 Hz (supply +10% max.) 46/37 VA
AMBIENT TEMPERATURE	-20°C/+60°C

MODEL	PORT SIZE Ø	NO. DIAPH.	PRESSURE RANGE (BAR)		WEIGHT KG	COIL	KV	CV
			MIN.	MAX.				
VNP206	3/4"	1	0.5	7.5	0.55	Yes	10	11.6
VNP208	1"	1	0.5	7.5	0.65	Yes	21	24.4
VNP212	1 1/2"	1	0.5	7.5	1.4	Yes	37	43.0
VNP214	1 1/2"	2	0.5	7.5	1.5	Yes	44	51.2
VNP216	2"	2	0.5	7.5	2.5	Yes	78	90.7
VNP220	2 1/2"	2	0.6	7.5	3.3	Yes	96	112
VEM206	3/4"	1	0.5	7.5	0.25	No	10	11.6
VEM208	1"	1	0.5	7.5	0.35	No	21	24.4
VEM212	1 1/2"	1	0.5	7.5	1.1	No	37	43.0
VEM214	1 1/2"	2	0.5	7.5	1.2	No	44	51.2
VEM216	2"	2	0.5	7.5	2.2	No	78	90.7
VEM220	2 1/2"	2	0.6	7.5	3	No	96	112

HOW TO ORDER

Part Number Code: **VEM/VNP 2 08 110/50**

Valve

N VNP - with integral pilot
E VEM - without pilot

2

"200 Series"

Voltage and frequency required

Valve connection diameter

- 06 = 3/4"
- 12 = 1 1/2" (single diaphragm)
- 14 = 1 1/2" (double diaphragm)
- 16 = 2"
- 08 = 1"
- 20 = 2 1/2"

MECAIR - 200 SERIES

THREADED VALVES

PRODUCT LEAFLET

DIMENSIONS (MM)

VNP 206 - 208 - 212

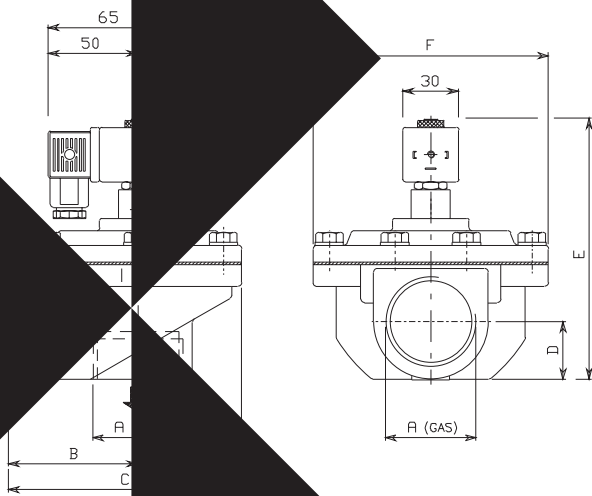

VEM 206 - 208 - 212

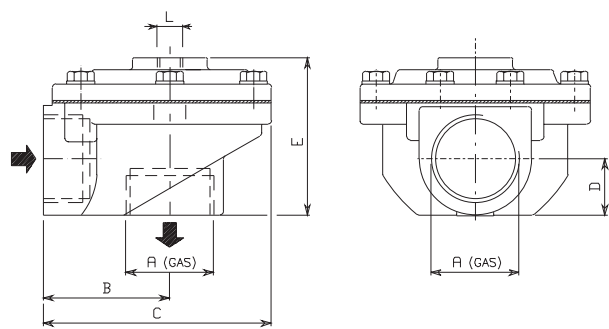

VNP 214 - 216 - 220

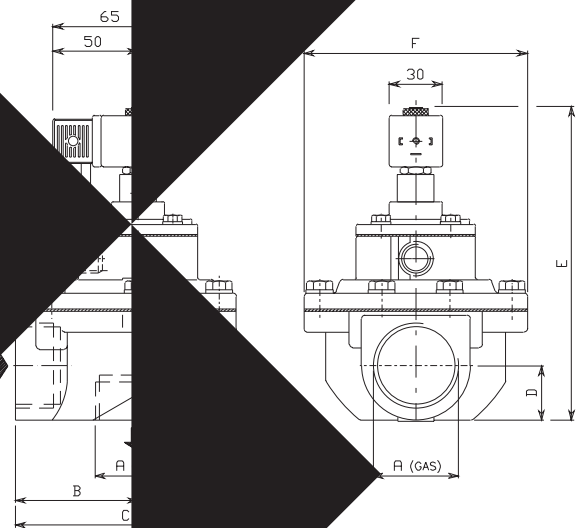

VEM 214 - 216 - 220

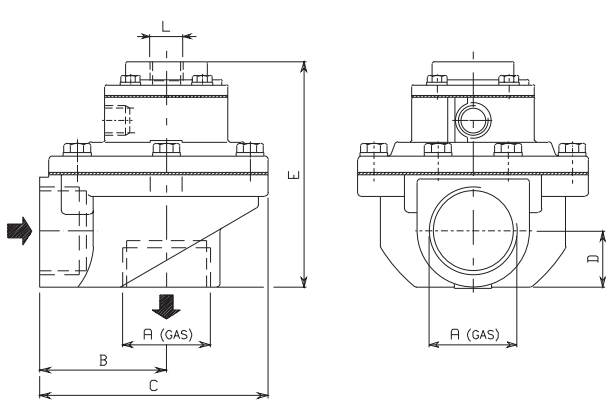

MODEL	Ø A	B	C	D	E	F	WEIGHT KG	MODEL	E	Ø L	WEIGHT KG	PRESSURE RANGE (BAR)		NO. DIAPH.
												MIN.	MAX.	
VNP206	3/4"	41	75	18	119	60	0.55	VEM206	59	1/4"	0.25	0.5	7.5	1
VNP208	1"	52	90	23	123	74	0.65	VEM208	63	1/4"	0.35	0.5	7.5	1
VNP212	1 1/2"	72	130	31	153	135	1.40	VEM212	93	1/4"	1.10	0.5	7.5	1
VNP214	1 1/2"	72	130	31	186	135	1.50	VEM214	126	1/4"	1.20	0.5	7.5	2
VNP216	2"	90	165	35	206	160	2.50	VEM216	146	1/4"	2.20	0.5	7.5	2
VNP220	2 1/2"	116	199	47	226	190	3.30	VEM220	166	1/4"	3.00	0.6	7.5	2

MECAIR - 200 SERIES

THREADED VALVES

PRODUCT LEAFLET

SPARE PARTS

VEM/VNP 206 - 208 - 212

VEM/VNP 214 - 216 - 220

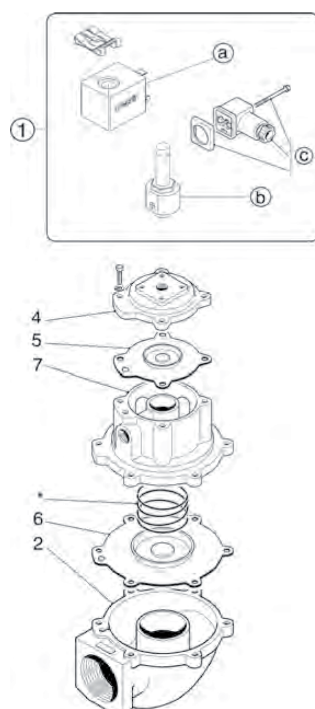
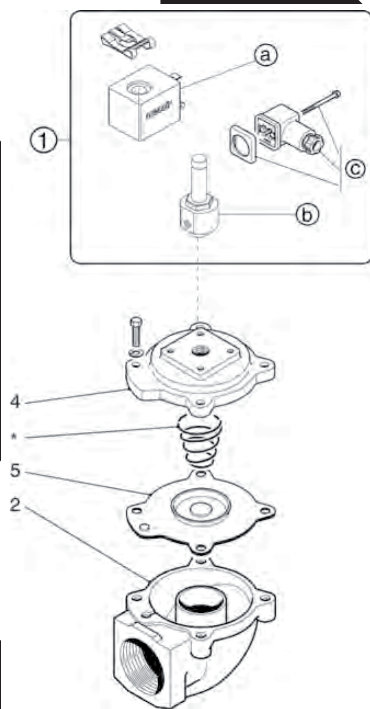

STANDARD VERSION

OPTIONAL VERSION

POS.	DESCRIPTION	CODE
1	a) Solenoid*	a) KIT SB4 - ../..* -18 W
	b) Pilot group complete with base and ferrule	b) KIT CP1/4
	c) DIN connector PG9EN175301-803 IP65	c) KIT PLG9

POS.	DESCRIPTION	CODE
1	a) Solenoid	a) KIT SB4 -24/ DCX -18 W
	b) Pilot group complete with base and ferrule	b) KIT CP1/4
	c) DIN connector (3GD IP65 T6)	c) KIT PLG11 - ATEX

Version in conformity with European Directive 94/9/CE ATEX (cod. KIT PV-24/DCX)

POS	DESCRIPTION	CODE					
		VEM/VNP206	VEM/VNP208	VEM/VNP212	VEM/VNP214	VEM/VNP216	VEM/VNP220
1	Pilot group complete with solenoid* and DIN connector	KIT PV - ../..*	KIT PV - ../..*	KIT PV - ../..*	KIT PV - ../..*	KIT PV - ../..*	KIT PV - ../..*
a+b+4	Pilot group complete with solenoid*, top cover and screws	KIT PVM06 - ../..*	KIT PVM08 - ../..*	KIT PVM12 - ../..*	KIT PVM06 - ../..*	KIT PVM06 - ../..*	KIT PVM06 - ../..*
2	Valve body	KIT M100201	KIT M100204	KIT M100211	KIT M100211	KIT M100218	KIT M300222
7	Intermediate cover (double diaphragm)	-	-	-	KIT M110098	KIT M110100	KIT M110101
4	Top cover	KIT M110082	KIT M110086	KIT M110092	KIT M110082	KIT M110082	KIT M110082
5	Diaphragm	KIT DB 16/G	KIT DB 18/G	KIT DB 112/G	-	-	-
5	Viton Diaphragm	KIT DB 16V/S	KIT DB 18V/S	KIT DB 112V/S	-	-	-
5+6+Spring	Diaphragm (main and secondary)	-	-	-	KIT DB 114/C	KIT DB 116/C	KIT DB 120/C
5+6+Spring	Viton Diaphragm (main and secondary)	-	-	-	KIT DB 114V	KIT DB 116V	KIT DB 120V

* Specify voltage and frequency.