

ABB MEASUREMENT & ANALYTICS | DATA SHEET

7650 / 7660 series

pH / Redox (ORP) electrode systems



Measurement made easy

Accurate and stable measurement
in critical conditions

Designed specifically for power and potable water industry applications

- where pH and REDOX (ORP) measurements are critical

Optical stainless steel flowcell

- essential for high purity water applications

Economical option for applications where the conductivity is above 20 $\mu\text{S}/\text{cm}$

- utilizing a polypropylene flowcell

Flowing reference junction option

- provides a very stable junction potential in high purity water or high suspended solids applications

Replaceable reference junction

- simple to replace for reliable, low-cost maintenance

Separate detachable-lead electrodes

- provides versatility and low-cost electrode replacement

Low resistance electrode option

- for fast response in low temperature applications

Target applications

pH and Redox (ORP) measurement for the power industry

The measurement of pH and Redox (ORP) in high purity water applications specifically in power plants requires a number of essential elements to achieve accurate and stable readings. These include: a stainless steel flowcell to minimize static effects, reservoir-fed reference junction that overcomes KCl depletion and blockage ensuring a stable junction potential and simple reference junction replacement for low-cost maintenance.

The 7660 system meets all these requirements in samples below 20 $\mu\text{S}/\text{cm}$ providing accurate measurement, vital for boiler chemistry control. For applications up to 100 $\mu\text{S}/\text{cm}$ the 7651 with polypropylene flowcell and the 7653 with a reservoir-fed reference electrode option are an ideal economical option.

pH measurement in potable water treatment

Accurate and stable pH measurement is required for optimum control at the coagulation stage of the process to minimize coagulation costs and treated water quality. Coagulation is a particularly difficult application due the high level of suspended solids and significant precipitation that frequently blocks the reference junction. The essential elements for such pH systems include: optional flowing reference junction that overcomes KCl depletion and blockage, simple reference junction replacement to provide a low-cost maintenance in samples that contain high levels of particulates and low resistance glass electrode option provides fast response in low temperature applications.

The 7600 Series meets all these requirements with the 7651 with polypropylene flowcell and the 7653 with a reservoir-fed reference electrode are an ideal low-cost option. Both systems are highly-suited throughout the potable water treatment process.

Sensors

A pH system is only as good as the sensors used to make the primary measurement. To satisfy the target applications, and to meet the demands of these critical processes, ABB have produced a range of electrodes to satisfy most requirements.

pH electrodes

There are two pH electrodes, for both polypropylene and stainless steel systems.

General purpose electrode

The general purpose electrode operates over 0 to 14 pH, 0 to 100 °C (32 to 212 °F) suitable for both boiler cycle and potable water applications.

Low resistance electrode

This unique low resistance glass membrane electrode is recommended for low-temperature applications. It is used extensively throughout the water industry, where its speed of response is important as the temperature drops below 10 °C (50 °F).

It can also be beneficial on low-conductivity potable water or (thin) waters less than 100 $\mu\text{S}/\text{cm}$.

Its operating range is 0 to 10 pH, 0 to 70 °C (32 to 158 °F).

Reference electrodes

The key to success in many applications is the reference electrode. ABB have devised a unique approach to providing a choice of sealed or reservoir-fed reference electrodes using the same reference element. This is achieved by making the outer junction part of the electrode system, enabling the replaceable reference electrode to be reduced significantly in price and minimizing stock holding, as the same electrode is used for all three versions.

Temperature compensation

A three-wire PT100 temperature compensator is required to ensure high accuracy, especially where the sample temperature fluctuates widely.

Platinum electrode for Redox (ORP)

The platinum electrode enables Redox (ORP) measurements to be made using all these electrode systems.

...Sensors

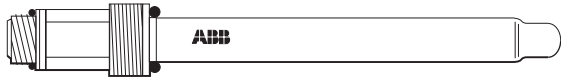

Model 1720-000 general purpose electrode

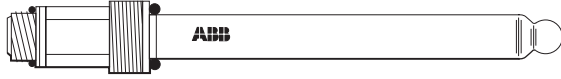

Model 1722-000 low resistance electrode



Model 1730-000 reference electrode

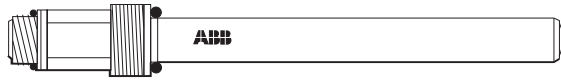

Model 1740-000 platinum metal electrode



Model 1750-000 temperature compensation

* Fitted to all systems

** Fitted to all systems except when model 1740 (Redox – ORP) is used or if manual temperature compensation is used

Range of electrodes

Connection cable

The connection cable used with this system comprises a multi-core cable with three IP67 plug connectors at one end and tag connectors at the other end. There are standard cables of 3, 5, 10 and 20 m (10, 16, 32 and 65 ft.) lengths. Non-standard length cables can be made up to a maximum of 100 m (325 ft.).

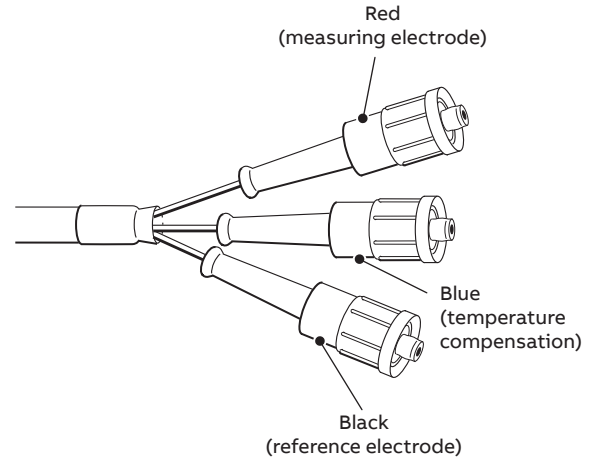

Quick-disconnect cable

7651 and 7653 polypropylene system

The 7651 features a specially-designed flowcell that permits operation in a wide variety of process installations. Its small cell volume ensures that representative readings are obtained at low flow rates, while the straight-through design minimizes silting or blocking from sample deposition. Process connections are 1 in. BSPT and ½ in. BSPT.

The 7653 includes a reservoir-fed reference electrode. The reference chamber needs topping-up only once every 2 months.



7651 polypropylene system

Specification

Body material

Coupled glass-reinforced polypropylene

pH range

0 to 14

Operating temperature range

-5 to 100 °C (23 to 212 °F)

Maximum operating temperature

- 7651 – 100 °C at 2.1 bar (212 °F at 30 lbf/in²)
see graph for details
- 7653 – 100 °C at atmospheric pressure

Maximum operating pressure

- 7651 – 10.6 bar (150 lbf/in²) at 25 °C (77 °F)
see graph for details
- 7653 – atmospheric

Process connections standard

1 in. BSPP female with ½ in. BSPT female adaptors (provided)

Mounting arrangements

Panel- or wall-mounting, bracket supplied

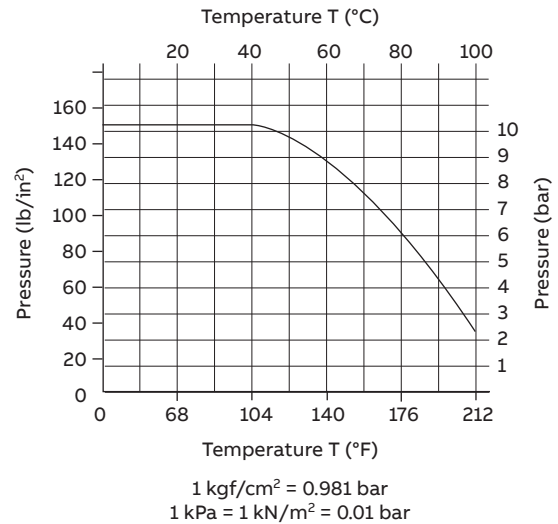

7651 flow system operating pressure v temperature

7660 stainless steel flow system

The 7660 stainless steel flow system, with reservoir-fed reference electrode, has been designed to achieve reliable and accurate results in low-conductivity waters (less than 20 $\mu\text{S}/\text{cm}$) at atmospheric pressure. The reservoir provides a simple approach to refilling the reference chamber by topping-up every 2 months

Ease of maintenance is a major feature. The system is available with $\frac{3}{8}$ in. NPT process connections.

The system has been evaluated extensively on low-conductivity waters and ammonia-dosed boiled feed water. When used with ABB transmitters it provides accurate results, referenced to 25 °C (77 °C).

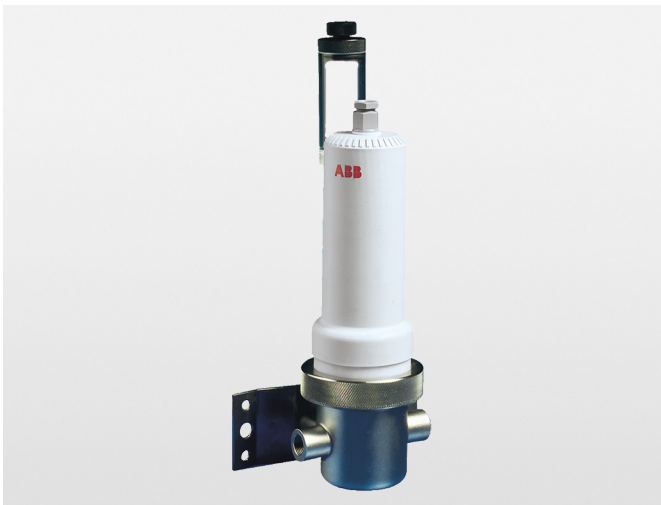

7660 stainless steel system

Specification

Body material

- Coupled glass-reinforced polypropylene
- Stainless steel flow cell

Operating temperature range

0 to 100 °C (32 to 212 °F) – with appropriate electrodes

Maximum operating temperature

Reservoir-fed reference electrode – atmospheric

Process connections

$\frac{3}{8}$ in. NPT female

Mounting arrangements

Panel- or wall-mounting, brackets supplied

Overall dimensions

Dimensions in mm (in.)

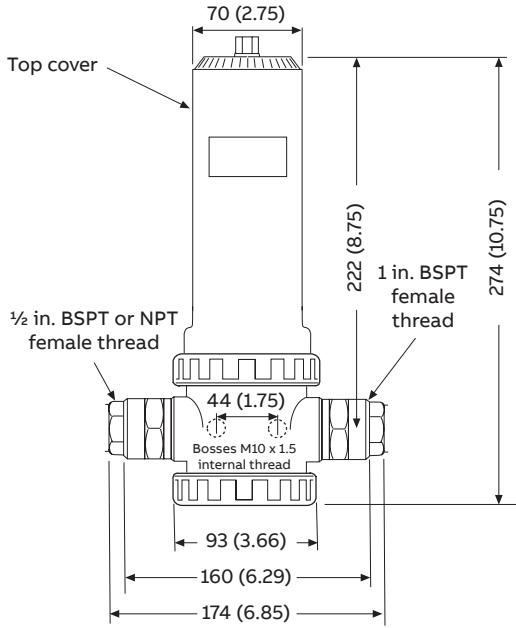

7651 polypropylene system

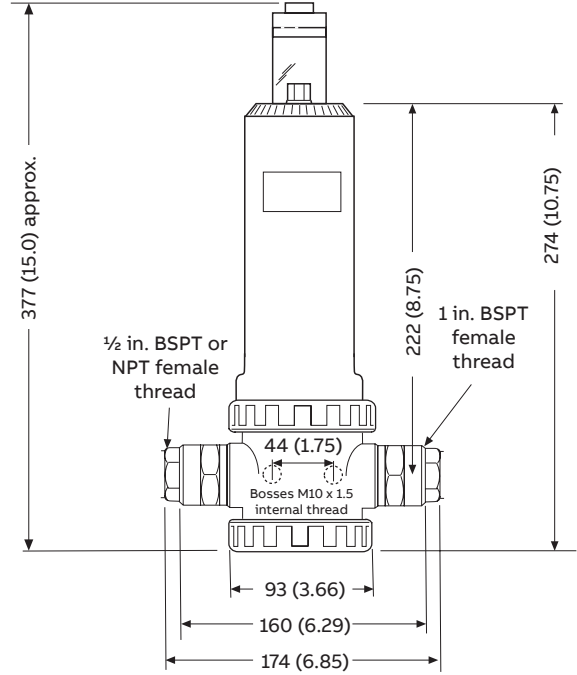

7653 polypropylene system

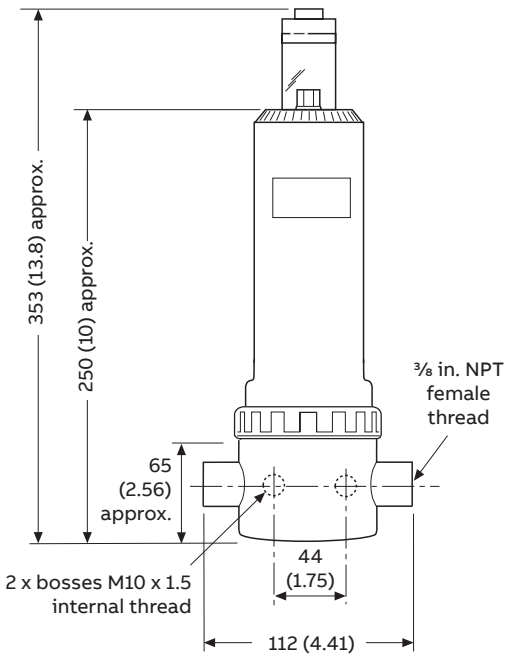

7660 stainless steel system

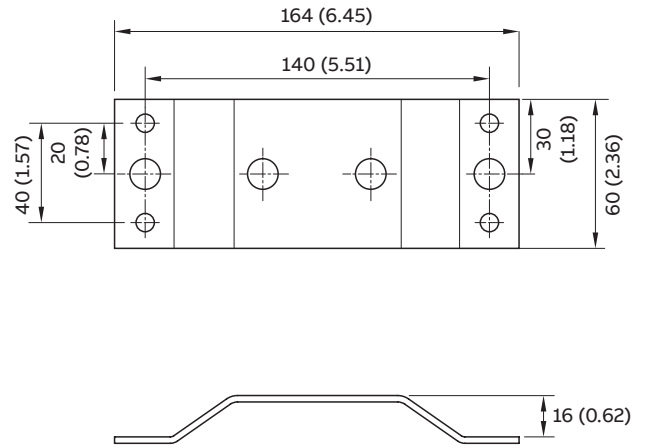

Note. Mounting bracket supplied as standard, complete with 2 x M10 bolts.

Mounting bracket (part number 7600-960)

Ordering information

7600 Series pH/Redox electrode system	76	XX /	0	X	X
System type and material					
Polypropylene systems					
Flow system with ½ in. and 1 in. process connections			51		
Flow system with ½ in. and 1 in. process connections (reservoir-fed reference version)			53		
Stainless steel system					
Flow system with ¾ in. process connections (reservoir-fed reference version)			60		
Connection cable length and type					
With automatic temperature compensation for pH					
No cable				0	
3 m (10 ft.) length				1	
5 m (16 ft.) length				2	
10 m (32 ft.) length				3	
20 m (65 ft.) length				4	
Short cable length, 1.25 m (4.1 ft.)				5	
For Redox / ORP					
No cable				0	
3 m (10 ft.) length				5	
5 m (16 ft.) length				6	
10 m (32 ft.) length				7	
20 m (65 ft.) length				8	
Special length				M	
Sensor types					
No sensor					0
1720-000 all purpose glass electrode					1
1730-000 standard reference electrode					
1750-000 PT100 temperature compensator					
Recommended for general purpose applications					
1722-000 low resistance glass electrode					2
1730-000 standard reference electrode					
1750-000 PT100 temperature compensator					
Recommended for low temperature applications <10 °C (50 °F)					
1740-017 platinum electrode (Redox/ORP)					5
1730-000 standard reference electrode					
For Redox/ORP applications					