

UNIMAR

***THE UNIVERSAL GAUGE
FOR MACHINE TOOLS***



MARPOSS

Description of the system

UNIMAR measuring heads are the ideal solution for all process control applications on machine tools. They are the basic element for creating gauging systems integrated in the process.

Universal application. The UNIMAR measuring head is the basic element for any type of process control gauging. UNIMAR can be used for all applications on machine tools, partly thanks to its miniaturization, making it easy to fit.

High level measuring performance combined with user-friendliness. The UNIMAR head features a high level of precision, long-term thermal stability and a large measurement range.

Total flexibility. The range of Unimar models not only eliminates operator intervention, but also allows maximum machine tool operating flexibility, with a resulting increase in productivity.

Maximum sturdiness. The design and materials used for the UNIMAR head give it an extremely high level of chemical and mechanical resistance.

Simple maintenance. The main components can be replaced from the outside, reducing the cost of maintenance and spare parts. Its make-up guarantees absolute reliability.

The UNIMAR head is the only one equipped with DATA (Digital Acquisition Tracking of Application) for saving application technical data and maintenance work records.

The heads can be connected to all Marposs electronic gauging amplifiers either directly, or via junction box, or using quick-release connectors.

Types of application

- Grinding for continuous/interrupted exteriors
- Grinding for continuous/interrupted interiors
- Grinding without centres
- Surface grinding
- Machining centres
- High precision lathes
- Lapping machines
- Superfinishing machines
- Post Process measuring stations

Advantages

- Versatility
- Compactness
- Precision
- Reliability
- Repeatability
- Sturdiness
- Easy installation
- Easy maintenance
- High thermal stability



The Unimar measuring heads are divided into several families, each suitable for different fields of application:

- Unimar S – small measurement range
- Unimar R – large retraction
- Unimar W – large measurement range
- Unimar P – positioner (small range) – retraction adjustable from outside
- Unimar L – positioner (large range) – retraction adjustable from outside
- Unimar A – absolute heads

Each family is made up of different models, having different technical specifications and operation: some “common” features are available for all heads (e.g.: pneumatic retraction, damping), others are special and are only available for particular models.

General characteristics:

- Stainless Steel Body
- IP66 - IP67
- Pre-stroke (externally adjustable)
- Overstroke (externally adjustable)
- Damping device for checking interrupted surfaces
- Measurement force (externally adjustable)

Code plan

BASIC CODE 3427848 X Y Z

Head Model [X]	Options [Y]								
	1	2	3	4	5	6	7	8	9
S - Short Range	1	S10							
			S26	S36					
				S38					
L - Locator	2				L46	L56			
R - Large Retraction	3	R10							
			R26	R36					
W - Wide Range	4	W10							
			W26	W36					
A - Absolute	5		A26	A36					
			A27	A37					
P - Positionar	6				P46	P56			

Model	Special Option [Z]
0	Standard
6	Standard
8	Special damping
6	Standard
0	Standard
6	Standard
0	Standard
6	Standard
7	Diameter mapping
6	Standard

NOTE: the term “pneumatic retraction” for a measuring head means management of the mechanical movement of the finger+contact assembly essential for avoiding their impact with workpiece/part surfaces during head insertion in/removal from the home position to the measuring position and vice versa. The retraction function is normally used when the aim is to measure: internal diameters of interrupted surfaces, groove diameters or for axial positioning on shoulders.

Unimar S - Short Range

Innovative precision

Unimar S is the measuring head designed by Marposs to guarantee the high precision performance and repeatability of the in process gauge family. It allows plenty of operating flexibility thanks to easy external adjustment of the mechanical calibration parameters.

Why choose it? Applications

Unimar S is the ideal solution for those who need a compact gauge, suitable both for continuous and interrupted surfaces. It is sturdy, flexible, quickly repaired and has measuring performance down to hundredths of a μm .

Technological advantages

The ideal partner in grinding systems, Unimar S boasts precision that allows it to be used in fields of application typical of the injector industry, where the tolerances needed are measured in microns. Unimar S achieves high standards of precision thanks to extremely low linearity, repeatability and thermal stability errors. Guarantees maximum reliability.

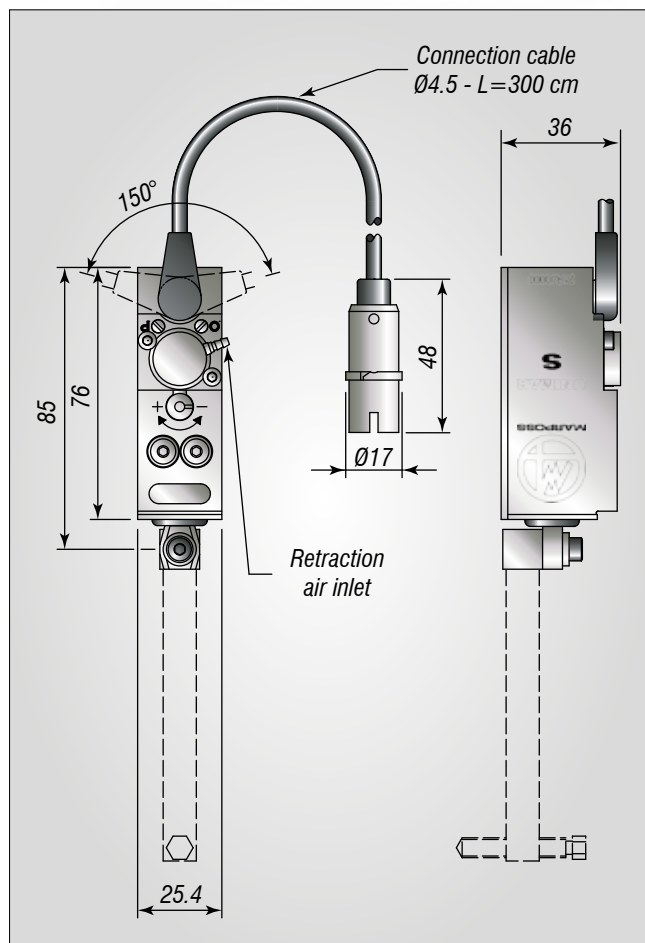

MEASUREMENT RANGE	$\pm 500 \mu\text{m}$
REPEATABILITY <i>range on 25 samples</i>	$< 0.1 \mu\text{m}$
THERMAL DRIFT	$< 0.08 \mu\text{m}/^\circ\text{C}$

Advantages

- Excellent repeatability
- Excellent linearity
- Adjustable retraction
- Adjustable measurement force
- Multiple damping possibilities

Types of application

- External diameters with continuous/interrupted surfaces
- Internal diameters with continuous/interrupted surfaces
- Active positioning

Unimar P

Precise positioning

This is the Unimar gauge version that, together with mechanical and measuring features characteristic of this family, has an external adjusting system to make precision adjustment of the mechanical overstroke easy in part positioning applications.

Why choose it? Applications

Unimar P is the ideal solution for all applications requiring very narrow positioning tolerances, both for continuous and for interrupted surfaces.

Technological advantages

They can be used both for active positioning (part brought into a predetermined position in the machine, by moving the part itself or the gauge), and for passive positioning (measurement of the generic position of a part in the machine).

All Unimar P heads have a rear shank for rapid retraction adjustment, as well as the usual pre-stroke and measurement force adjustments.

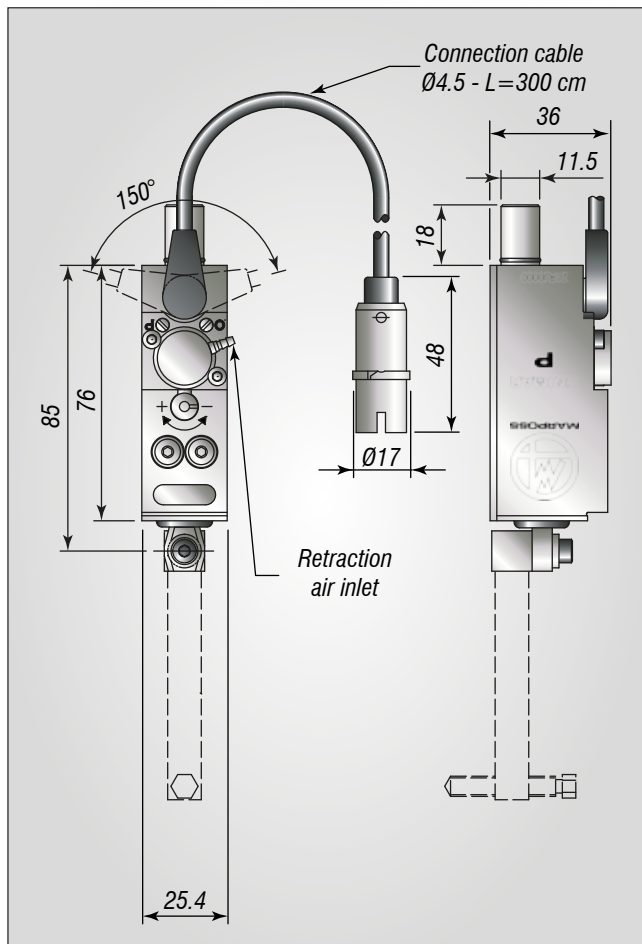

MEASUREMENT RANGE	$\pm 1000 \mu\text{m}$
REPEATABILITY <i>range on 25 samples</i>	$< 0.1 \mu\text{m}$
THERMAL DRIFT	$< 0.08 \mu\text{m}/^\circ\text{C}$
MAXIMUM RETRACTION VALUE	$1200 \mu\text{m}$

Advantages

- Excellent repeatability
- Excellent linearity
- Retraction rapidly adjustable from the back of the gauge
- Adjustable measurement force

Types of application

- Active positioning on continuous or interrupted surfaces
- Passive positioning on continuous or interrupted surfaces
- Distance between two shoulders
- Active centring
- Passive centring

Unimar L

Flexible positioning

This is the Unimar gauge version that, as well as having the external adjusting system to make precision adjustment of the mechanical overstroke easy in part positioning applications, guarantees a large measurement range to allow flexible part positioning.

Why choose it? Applications

Unimar L is the ideal solution for all flexible applications requiring positioning cycles on various types of parts without the need for mechanical retooling.

Technological advantages

They can be used both for active positioning (part brought into a predetermined position in the machine, by moving the part itself or the gauge), and for passive positioning (measurement of the generic position of a part in the machine).

All Unimar L heads have a rear shank for rapid retraction adjustment, as well as the usual pre-stroke and measurement force adjustments.

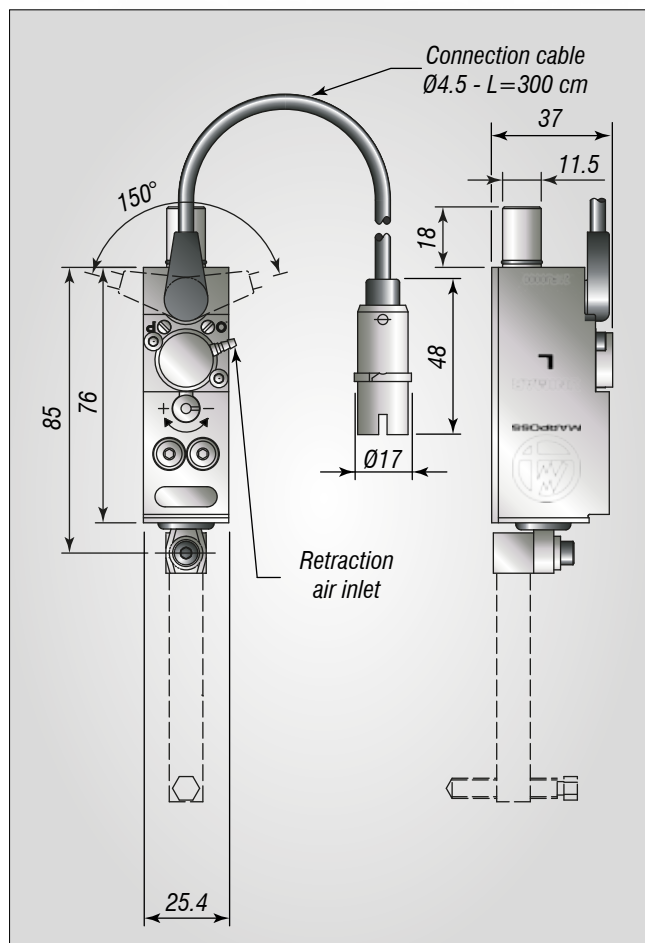

MEASUREMENT RANGE	$\pm 2000 \mu\text{m}$
REPEATABILITY <i>range on 25 samples</i>	$< 0.2 \mu\text{m}$
THERMAL DRIFT	$< 0.11 \mu\text{m}/^\circ\text{C}$
MAXIMUM RETRACTION VALUE	0-3000 μm

Advantages

- High level of repeatability
- High level of linearity
- Retraction rapidly adjustable from the back of the gauge
- Adjustable measurement force

Types of application

- Active positioning on continuous or interrupted surfaces
- Passive positioning on continuous or interrupted surfaces
- Distance between two shoulders
- Active centring
- Passive centring

Unimar W

Flexible measurement

This is the Unimar gauge version equipped with a special transducer able to control the movement of its measurement range in a maximum range of 12.5mm
 If two Unimar W cells are used as a pair, they can measure internal diameters within a 1" (25.4 mm) range without needing any mechanical adjustment.

Why choose it? Applications

Unimar W is the ideal solution for all applications requiring maximum flexibility to be able to measure various types of parts without mechanical retooling.

Technological advantages

Ideal partner for flexible production processes in which the part types being processed change constantly.
 Available in versions with or without retraction and also suitable for multicomparator checks on continuous and interrupted surfaces.

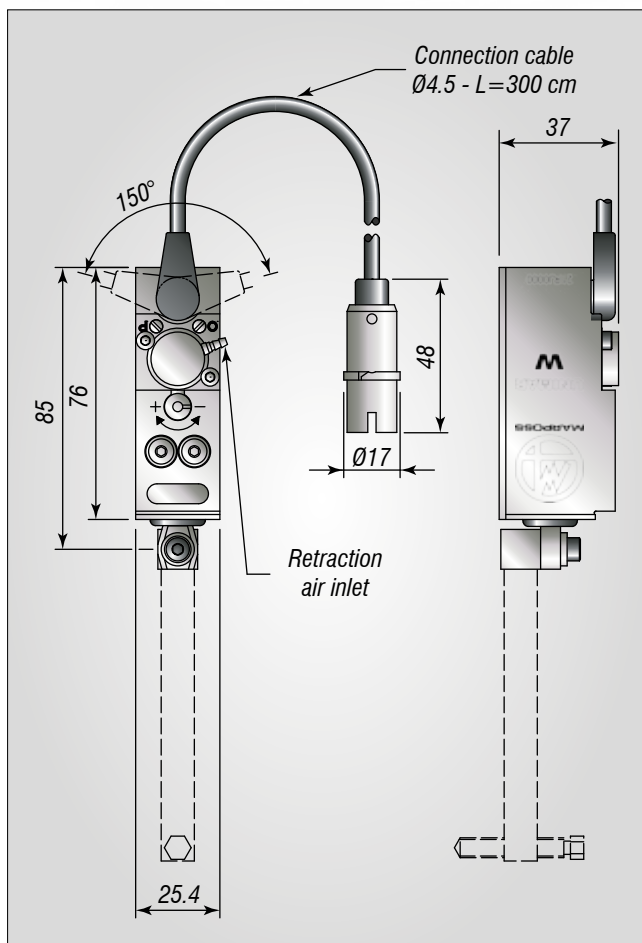

TYPICAL MEASUREMENT RANGE	±5700 µm
REPEATABILITY <i>range on 25 samples</i>	<0.2 µm
THERMAL DRIFT	<0.11 µm/°C
MAXIMUM RETRACTION VALUE	6100 µm

Advantages

- High level of repeatability
- High level of linearity
- Adjustable measurement force
- Adjustable pre-stroke (from the rear for several models)
- Adjustable overstroke
- Possibility of measuring sections having different diameter without retooling
- Rapid part type changeover (if within the same range)

Types of application

- External diameters with continuous/interrupted surfaces
- Internal diameters with continuous/interrupted surfaces
- Flat continuous/interrupted surfaces

Unimar R

Large retraction

This is the Unimar gauge version with a special mechanical solution able to guarantee contact retraction of up to 14 mm.

Why choose it? Applications

Unimar R measuring heads are the perfect solution for applications involving types of parts with particular geometries, requiring considerable retraction to allow measurement at the desired point.

Technological advantages

Ideal for applications such as measuring cams, and for bearing grooves.

As well as the standard models (with retraction, with damping) there are many special models developed for particular applications.

Those special solutions include the possibility of having heads made of completely non-magnetic material.

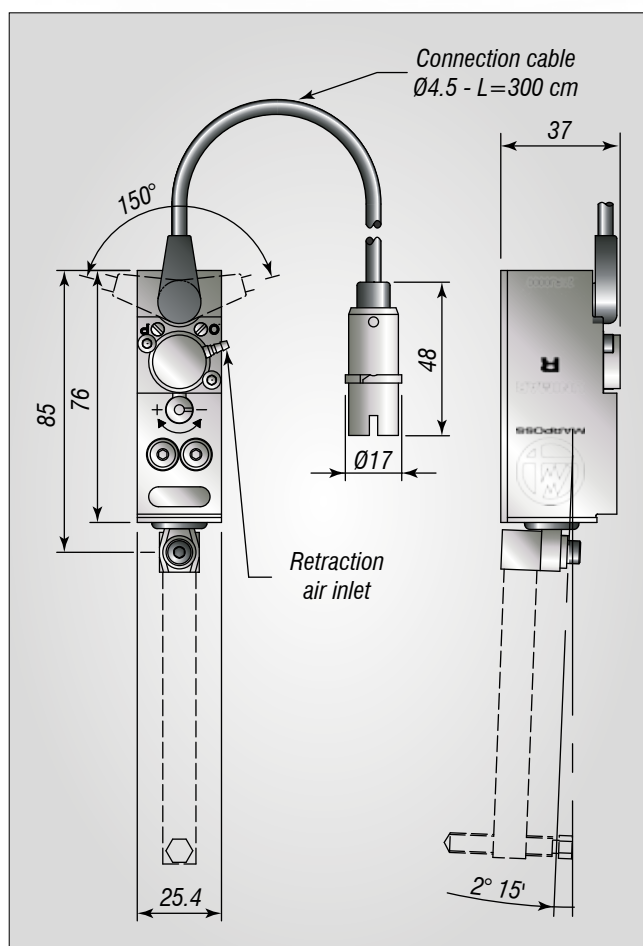

TYPICAL MEASUREMENT RANGE	$\pm 1000 \mu\text{m}$
REPEATABILITY <i>range on 25 samples</i>	$< 0.2 \mu\text{m}$
THERMAL DRIFT	$< 0.11 \mu\text{m}/^\circ\text{C}$

Advantages

- High level of repeatability
- High level of linearity
- High retraction value
- Adjustable measurement force
- Adjustable pre-stroke
- Adjustable overstroke
- Possibility of non-magnetic material

Types of application

- External diameters with continuous/interrupted surfaces
- Internal diameters with continuous/interrupted surfaces
- Active positioning
- Applications for semiconductors
- Applications for bearings
- Applications for cam measurement

Unimar A

Absolute Measurement

This is the Unimar gauge version developed to meet application requirements that call for absolute measurement rather than multi-comparison.

Why choose it? Applications

Unimar A is the ideal solution for all applications that need a 12.5 mm measurement range for the contact (25 mm diameter) without mechanical retooling and multiple masters for multi-comparison measurement.

Technological advantages

Ideal partner for flexible production processes in which the part types being processed change constantly. By taking an absolute measurement, it does not need a reference master for each diameter measured.

Available in versions with or without retraction and also suitable for checks on continuous and interrupted surfaces. Supplied exclusively for use with the BLÚ system.

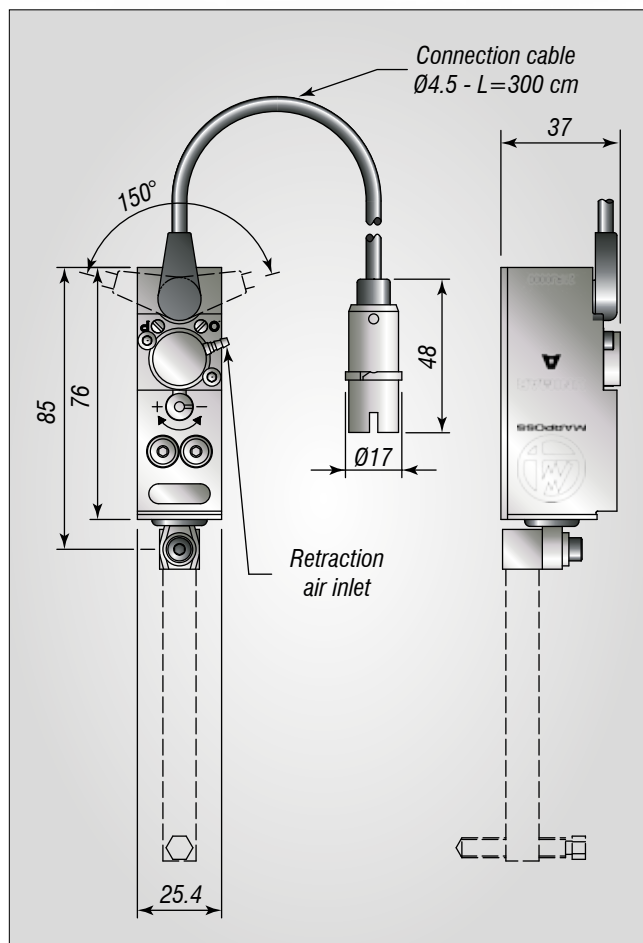

REPEATABILITY <i>range on 25 samples</i>	<0.2 μm
THERMAL DRIFT	<0.11 $\mu\text{m}/^\circ\text{C}$

Advantages

- Excellent repeatability
- Excellent linearity
- Adjustable measurement force
- Adjustable pre-stroke
- Adjustable overstroke

Types of application

- Length measurement
- Centring
- External diameters with continuous/interrupted surfaces
- Internal diameters with continuous/interrupted surfaces
- Active/passive positioning

Accessories

The extreme application flexibility of gauging solutions with Unimar heads is also made possible thanks to the related accessories, allowing each application to be correctly configured according to the type of machine, type of part and the performance required.

Fingers

As for contacts, there are also many solutions for fingers: the choice is based on the type of contact to be accommodated, length and offset.

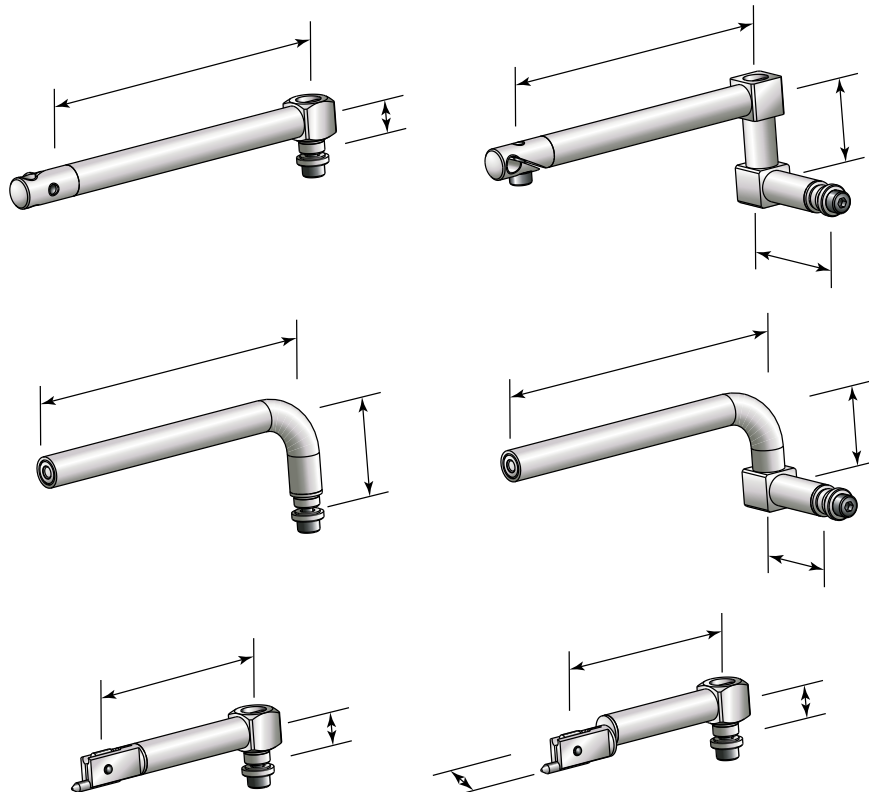

Zeroing guides

There are various types of rapid zeroing guides that can be used to set-up the measuring heads simply, accurately and rapidly. Customers can choose the solution that best suits their requirements, depending on the type of application.

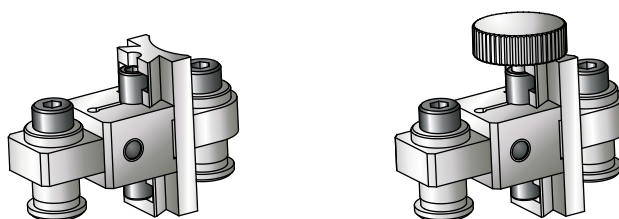

Contacts

There are many types of contacts, standard or special, which differ from one another according to shape and material.

Length, diameter and rounding are parameters which can be decided according to the type of part to be measured. Contact shapes: punctiform (1), bar-shaped (2) or with shoe (3), having a tip made of tungsten carbide or diamond, are selected depending on the type of application.

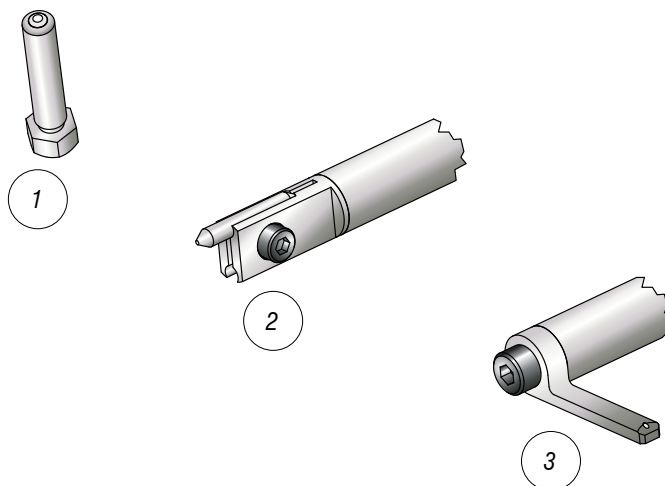

Supports

There are many support options depending on the type of application (parameters to be considered: measurement range and tip height) and the level of retoolability required. The supports may be integrated with a slot, quick-retooling equipment and a shower. Supports and measuring heads may also be mounted on linear slides (with hydraulic, pneumatic or electro-mechanical operation).

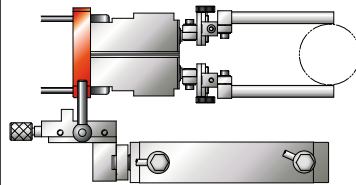

Application with fixed support

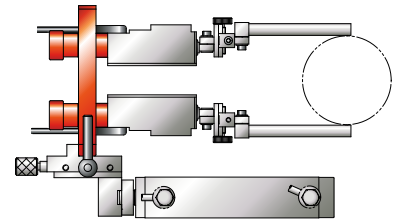

Application with fast retooling support

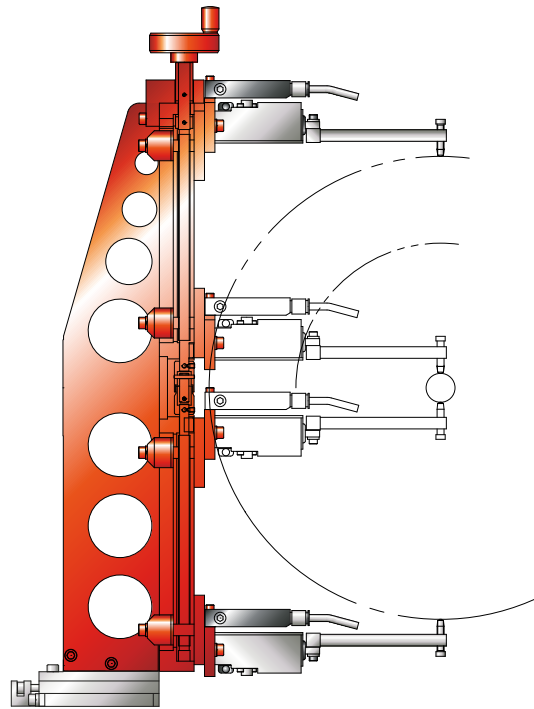

Application with quick set-up support

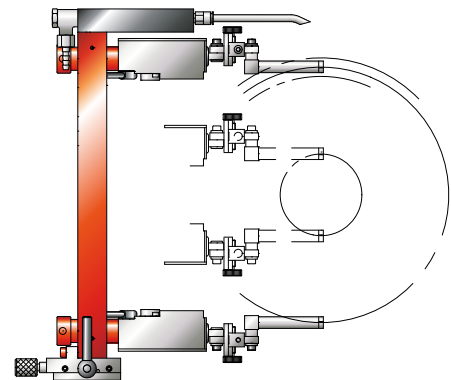

Application with support for internal diameters