

# Motion control, dual setting with brake release port

VAA-B-SICN-PDRM-VF-150

05.71.47 - X - 04 - Z

**RE 18308-82**

Edition: 03.2016

Replaces: 07.2012

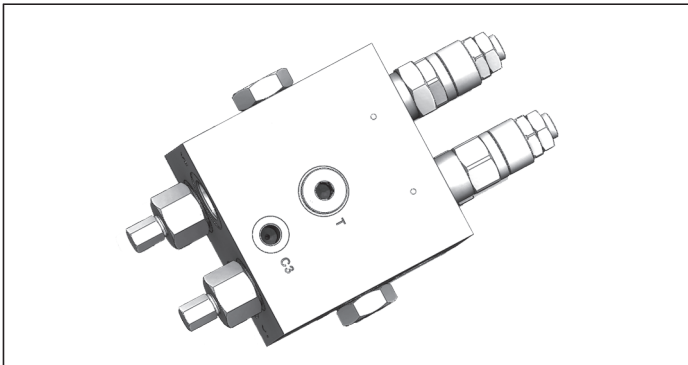

## Description

It provides static and dynamic motion control by regulating flow and pressure IN and OUT of the hydraulic motor at ports C1 and C2. When installed close to the motor, it can stop runaway in case of hose failure. The check sections allow free flow into the motor and prevent reverse movement; the pilot assisted relief valves control the movement when pilot pressure is applied. The relief valves operate with 2-levels pressure setting, both adjustable: higher setting when flow is delivered to the motor, and lower setting when flow is discharged by the motor during stopping. A system of check valves allows cross line relief and an optional make-up port (T) allows to compensate for any volume change. Through port C3, a shuttle valve directs either V1 or V2 pressure to the spring actuated brake for brake releasing.

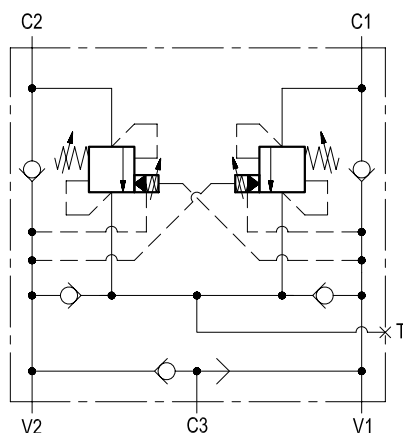

## Technical data

Operating pressure	up to 210 bar (3000 psi)
Max. flow	120 l/min. (32 gpm)
Weight	5.7 kg (12.6 psi)
Manifold material	Aluminium
Note: aluminium bodies are often strong enough for operating pressures exceeding 210 bar (3000 psi), depending from the fatigue life expected in the specific application. If in doubt, consult our Service Network.	
Fluid	Mineral oil (HL, HLP) according DIN 51524
Fluid temperature range	-30 °C to 100 (-22 to 212 °F)
Viscosity range	10 to 500 mm <sup>2</sup> /s (cSt)
Recommended degree of fluid contamination	Class 19/17/14 according to ISO 4406
Other technical data	see data sheet 18350-50

Relief setting: at least 1.3 times the highest expected load.

The lower pressure setting (see table "SPRINGS") refers to flow "C1" to "C2" (or "C2" to "C1"), and is adjustable through register "A" (see the drawing).

Note: for applications outside these parameters, please consult us.

## Characteristic curve

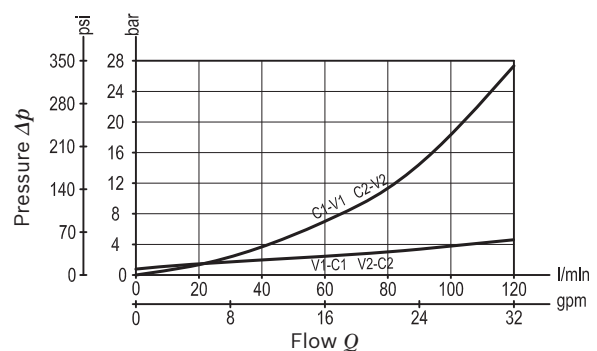

**Ordering code**

<b>05.71.47</b>	<b>X</b>	<b>04</b>	<b>Z</b>
-----------------	----------	-----------	----------

Motion control, dual setting

Pilot ratio

**03** 7.6:1

Port sizes	V1 - V2	C1 - C2	C3	T
	G 3/4	G 3/4	G 1/4	G 1/2

SPRINGS		
Adj. pressure range bar (psi)	Pres. increase bar/turn (psi/turn)	Std. setting Q=5 (l/min) bar (psi)
<b>35</b> 100-350 (1450-5000)	105 (1523)	300 (4350) 120* (1740)

\* Lower pressure setting.

Tamper resistant cap code  
ordering code 03.05.01.001  
Mat. no. R930000470

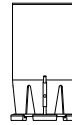

**Preferred types**

Type	Material number
05714703043500B	R930006860

Type	Material number

**Dimensions**

