



EDC-1

DIGITAL AMPLIFIER FOR SINGLE SOLENOID PROPORTIONAL VALVES IN OPEN-LOOP SERIES 10

PLUG-IN VERSION

OPERATING PRINCIPLE

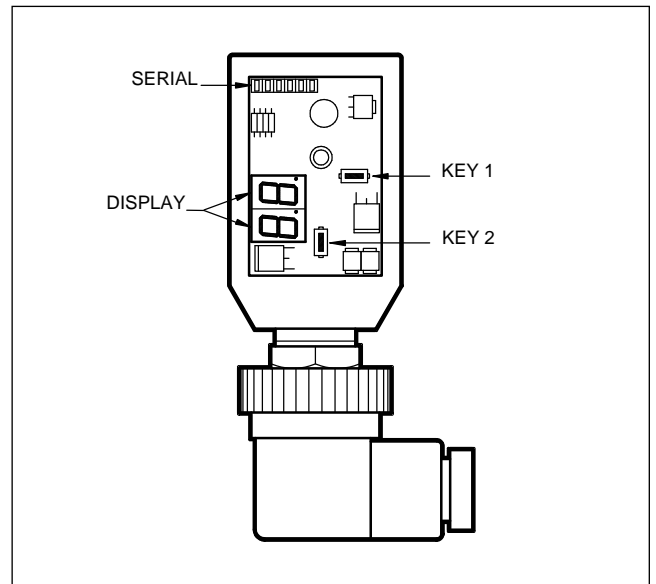
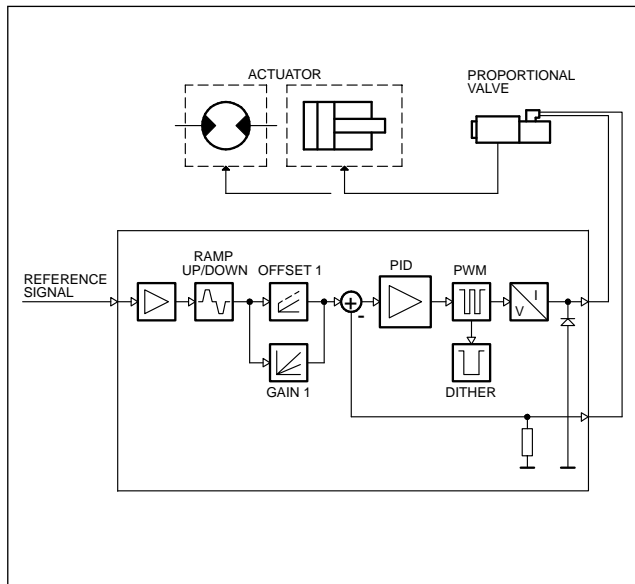

TECHNICAL CHARACTERISTICS

Power supply	V DC	10 ÷ 30 - ripple included
Required power	W	min 20 - max 40 (see point 2.1)
Output current	mA	min 800 - max 2600 (see point 1)
Power supply electrical protections		overload over 33 V polarity inversion
Output electrical protections		short-circuit
Analogue electrical protections		up to 30 V DC
Available reference signals	V V mA	0 ÷ 10 (input impedance 100 kΩ) 0 ÷ 5 (input impedance 100 kΩ) 4 ÷ 20 (input impedance max 500 Ω)
Connector type on PLC side		EN 175301-803 (ex DIN 43650) or M12 4 pin
Electromagnetic compatibility (EMC): - EMISSIONS IEC EN 61000-6-4 - IMMUNITY IEC EN 61000-6-2		according to 2014/30/EU standards (see point 5 - NOTE 1)
Protection to atmospheric agents (IEC EN 60529)		IP65/IP67
Operating temperature range	°C	-20 / +70
Mass	kg	0,10

1 - IDENTIFICATION CODE

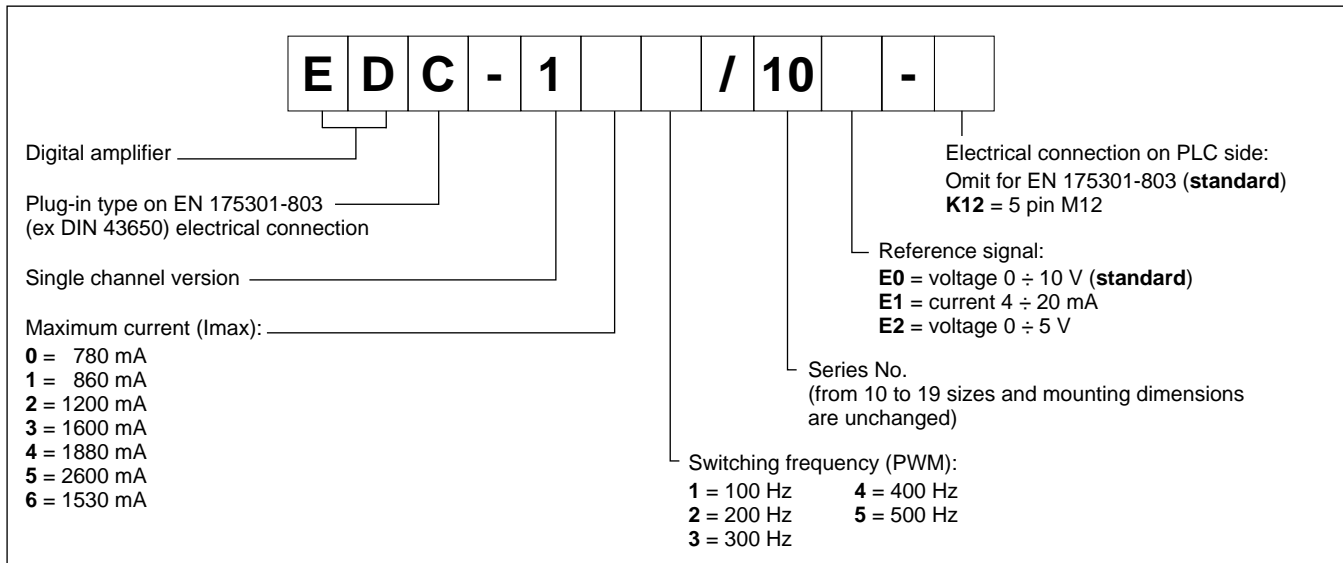

The EDC-1 is a digital amplifier for open-loop control of proportional valves with DIN-type coils, to be plugged directly onto the valve's electrical connection.

It delivers a current proportional to the reference signal, independent of changes in temperature and load impedance, with a resolution of 1% with full-scale 2600 mA.

The PWM stage on the solenoid power supply makes possible to reduce the valve hysteresis, optimizing control precision.

Setting is by keys and display inside the device case, or by the EDCPC software installed on a notebook via RS232 (see point 6.2).

2 - FUNCTIONAL SPECIFICATIONS

2.1 - Electric power supply

The device requires a power supply of 10 ÷ 30 V DC (terminals 1 and 2).

NOTE: The value of the power supply voltage on the device must be higher than the rated working voltage of the solenoid to be controlled.

The power supply voltage must be rectified and filtered, with maximum admissible ripple within the above voltage range.

The power required by the amplifier depends on the power supply voltage and on the maximum value of the supplied current (it is determined by the chosen version). A conservative value of the required power can be considered as the product of $V \times I$.

Example: EDC with maximum current = 2600 mA, with power supply voltage 12 V DC, requires a power of about 32 W.

When maximum current = 1600 mA and power supply voltage is 24 V DC, the required power is around to 38.5 W.

2.2 - Electrical protection

The device is protected on the power supply against overvoltage and reverse polarity. Short-circuit protection is provided on the output.

2.3 - Reference signal

The device accepts voltage reference signals with 0 ÷ 10 V and 0 ÷ 5 V, in 4 ÷ 20 mA current, from an external generator (PLC, CNC) or external potentiometer.

See point 7 for electrical connections referring to the different versions.

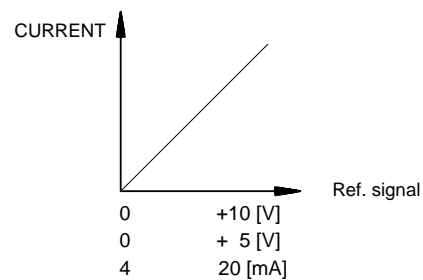

3 - POWER ON (POWER SUPPLY)

The lit display indicate that the connector is ON and with +24V DC.

4 - ADJUSTMENTS

There are two display modes:

- 1) Variable overview: real-time monitoring of the control values, for both expected and actual current.
- 2) read and edit operating parameters.

4.1 - Variables overview

The card switches-on in the variables view mode, and shows the actual reference signal (U1 parameter) .

Pushing key (1) the current to solenoid (C1 parameter) is displayed. By means of (1) key, different variables can be selected.

Each time a variable is displayed, its short name is shown for about a second.

Variables that can be selected are:

- U1:** Reference signal:
0 + 10 V
0 + 5 V
4 ÷ 20 mA (displayed as 2 ÷ 10)
- C1:** Required current, according to the applied reference signal, expressed in ampere, ranging between 0 A and 2.6 A

All the mentioned variable can be viewed on the display.

The selected value has to be read as follows (example for EDC-15*/10E* card):

REFERENCE		DISPLAY U1		DISPLAY C1
(V)	(mA)	(V)		(Ampere)
0	4	0.0	2.0	40 (mA)
5	12	5.0	6.0	13 (A)
10	20	10.	10.	26 (A)

4.2 - Parameters editing

To access the parameter editing, press the key (2) for at least 3 seconds.

The first parameter displayed is G1.

To modify it, press the key (1) for two seconds, until the display starts flashing. Use the key (2) to increase the value and the key (1) to decrease it. To save a new value, press both the keys.

The display stops flashing.

By pressing the key (2) again it is possible to scroll through all the parameters. To modify another parameter, repeat the steps described above.

Parameters that can be edited are:

G1: "I Max" current, expressed in milliamperes.

It sets the maximum current to the solenoid, when the reference signal is at the maximum value of +10 V (or 20 mA). It limits the maximum value of the hydraulic size controlled by the valve.

Default value = I max
Range = 50 ÷ 100% of I max

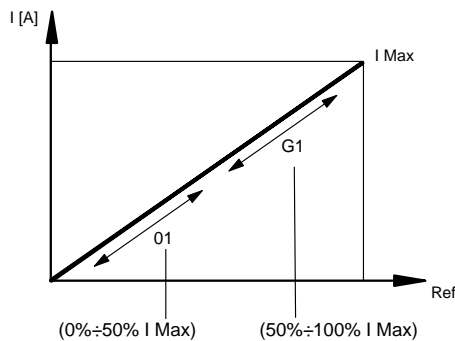

o1: "OFFSET1" current, expressed in milliamperes.

It sets the offset current to the solenoid, when the reference signal exceeds the limit of 0,1 V (or 0,1 mA).

It wipes out the insensitiveness area of the valve (dead band).

Default value = 0%
Range = 0 ÷ 50% of I max

Fr: PWM frequency, in Hertz.

It sets the PWM frequency, which is the pulsating frequency of the control current.

Decreasing the PWM improves the valve accuracy, decreasing the stability of the regulation. Increasing the PWM improves the control steadiness, but causes more hysteresis.

Default value = PWM (according to card version)
Range = 50 ÷ 500 Hz

u1: "Ramp Up" increasing ramp time, expressed in seconds.

It sets the current increasing time, for a variation from 0 to 100% of the input reference.

It slows down the valve response time in case of a sudden variation of the reference signal.

Default value = 00 sec.

Range = 00 ÷ 50 sec.

d1: "Ramp Dn" decreasing ramp time, expressed in seconds.

It sets the current decreasing time, for a variation from 100% to 0 of the input reference.

It slows down the valve response time in case of a sudden variation of the reference signal.

Default value = 00 sec.

Range = 00 ÷ 50 sec.

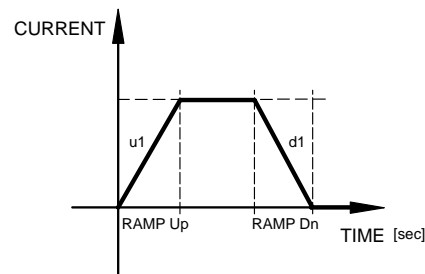

4.3 - Error signals

EE: Breakdown cable error on 4 ÷ 20 mA signal (threshold 3 mA).
Reset the alarm turning off the +24 V DC.

5 - INSTALLATION

This plug-in amplifier is designed to be mounted directly onto the DIN-type coil of the proportional valve to be controlled, to which it carries both the power supply and the reference signal.

NOTE 1: the electrical connection of the amplifier must strictly comply with the connection diagram shown in point 7 of this catalog in order to comply with the EMC requirements.

As a general rule, the valve and the connecting cables of the amplifier must be kept as far away as possible from sources of interference (e.g. power wires, electrical motors, inverters and electrical switches).

In environments particularly abounding in electromagnetic interferences, a complete shielding of the connection cables may be required.

6 - SET UP AND SETTINGS

6.1 - Set up

Change the configuration of the device using buttons (1) and (2) on the device itself or via the EDCPC/10 software kit, to be ordered separately.

6.2 - EDCPC/10 Software kit (code 3898301001)

This software kit allows easy parameter reading and amplifier setting from a PC. The EDC-1 device must be connected to the PC via an RS232 - USB 3.0 adapter cable, included in the kit.

The RS232 port is located under the protective cover of the amplifier, which can be removed by unscrewing the screw.

The EDCPC/10 software is supplied on a USB stick and is compatible with Microsoft Windows 2000, XP, Vista and Windows 7 operating systems.

7 - ELECTRIC CONNECTIONS ON PLC SIDE

standard connection

EN 175301-803 (ex DIN 43650)
3 pin + GND

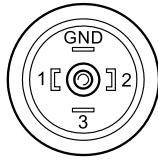

pin	E0	E1	E2	NOTE
1	24 V			supply voltage
2	0 V			
3	0 ÷ 10 V	4 ÷ 20 mA	0 ÷ 5 V	reference signal
GND	0 V			

K12 connection

Connection M12x1
5 pin

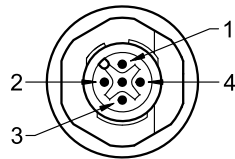

pin	E0	E1	E2	NOTE
1	24 V			supply voltage
2	0 ÷ 10 V	4 ÷ 20 mA	0 ÷ 5 V	reference signal
3	0 V			0V reference for pin 1
4	0 V			0V reference for pin 2
5	-			not connected

8 - WIRING DIAGRAMS

EDC-1**/10E*

EN 175301-803 (ex DIN 43650)

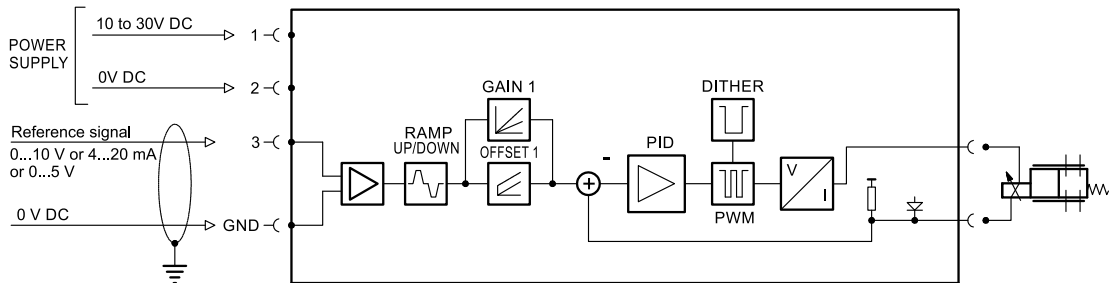

EDC-1**/10E*-K12

Connection M12x1

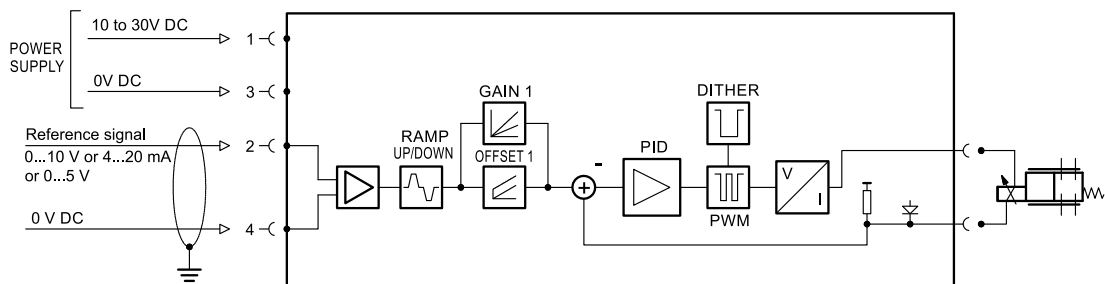



9 - OVERALL AND MOUNTING DIMENSIONS

9.1 - EDC-1**/10E*

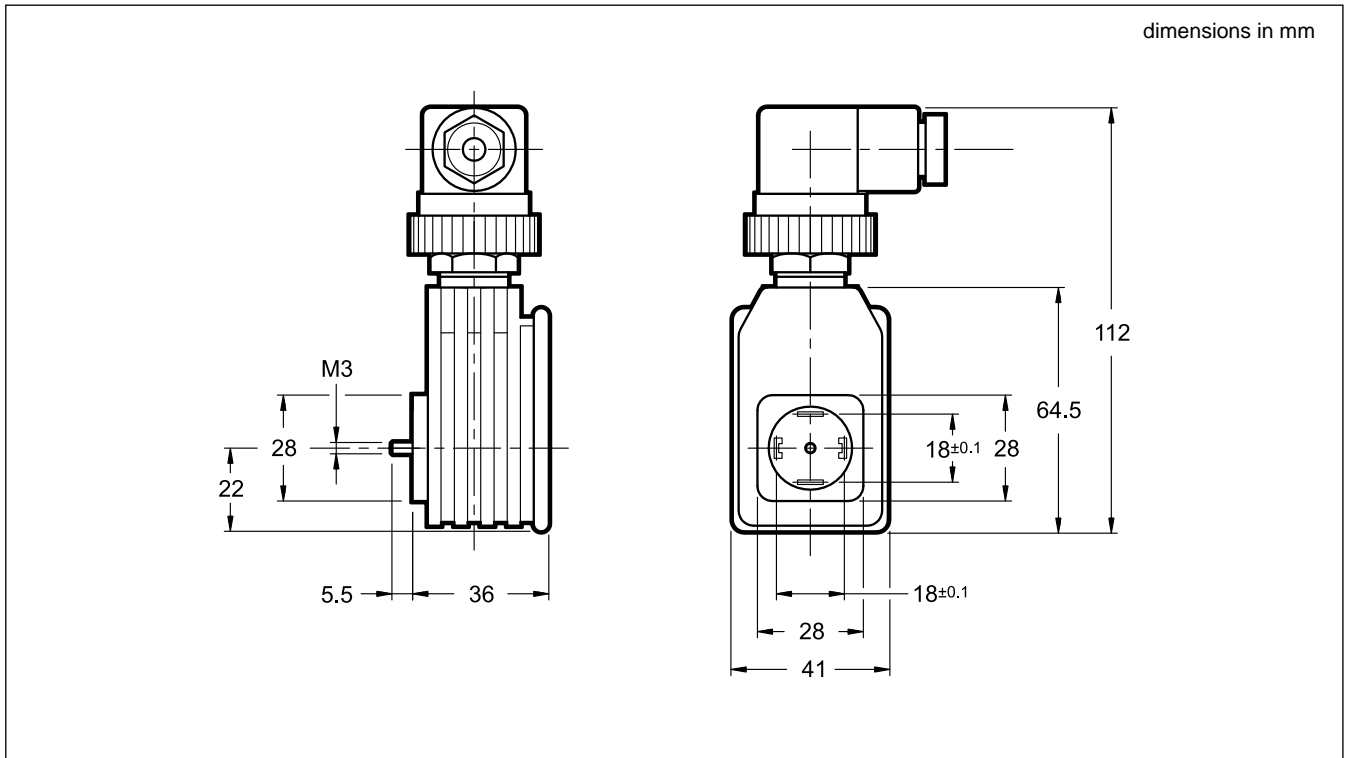

9.2 - EDC-1**/10E*-K12

