



FINISH THOMPSON INC.

S Series Motors

Model S6

Operation & Parts Manual

P/N 108004 Rev 5



Introduction

This manual pertains to the S6 rechargeable drum pump motor. Finish Thompson, Inc. thanks you for choosing our products. We believe that the use of our products will be fully satisfactory. When properly installed and operated, your Finish Thompson motor and pump will provide long, trouble-free service; therefore please read this manual carefully before carrying out any operations on the pump-motor unit. Any use other than that described herein is considered incorrect and consequently Finish Thompson, Inc. shall not be held responsible for any damages to people or things.

Index

Introduction	6
General Terms & Conditions, Warranty	7
Safety	8-9
Important Safety Information for Pumping Flammable or Hazardous Substances	10
Installation	11
Motor Operation.....	12
Charger Operation.....	12
Battery Pack Removal.....	13
Troubleshooting.....	13
Wall Hanger Instructions.....	14
Specifications & Identification	15
Spare Parts	16

Warranty, General Terms & Conditions

1. The following terms and condition apply to the sale of machinery, components and related services and products, of Finish Thompson, Inc. (hereinafter “the products”)
2. Finish Thompson, Inc. (the manufacturer) warrants only that:
 - a.) its products are free of defects in material, design and workmanship at the time of original purchase;
 - b.) its products will function in accordance with Finish Thompson, Inc. operation manuals; Finish Thompson, Inc. does not guarantee that the product will meet the precise needs of the Customer, except for those purposes set out in any invitation to render documents or other documents specifically made available to Finish Thompson, Inc. before entering into this agreement;
 - c.) high quality materials are used in the construction of the pumps and that machining and assembly are carried out to the highest standards. Except as expressly stated above, Finish Thompson, Inc. makes no warranties, express or implied, concerning the products, including all warranties of fitness for a particular purpose.

This warranty shall not be applicable in circumstances other than defects in material, design, and workmanship. In particular warranty shall not cover the following:

- d.) Periodic checks, maintenance, repair and replacement of parts due to normal wear and tear;
- e.) Damage to the product resulting from:
 - i. Tampering with, abuse or misuse, including but not limited to failure to use the product for its normal purposes as stated at the time of purchase or in accordance with Finish Thompson, Inc. instructions for use and maintenance of the product, or the installation or improper ventilation or use of the product in a manner inconsistent with the technical or safety standard in force;
 - ii. Repairs performed by non-authorized service workshop, or opening of the unit by non-authorized personnel, or use of non genuine Finish Thompson, Inc. parts;
 - iii. Accidents, force majeure or any cause beyond the control of Finish Thompson, Inc., including but not limited to lightning, water, fire, earthquake, and public disturbances, etc.;
3. The warranty shall cover the replacement or repair of any part, which is documented to be faulty due to construction or assembling, with new or repaired parts free of charge delivered by Finish Thompson, Inc. Parts subjected to normal wear and tear shall not be covered by the warranty. Finish Thompson, Inc. shall decide as to whether the defective or faulty part shall be replaced or repaired. Transportation charges are prepaid to Finish Thompson.
4. The warranty of the products shall be valid for a period of 12 months from the date of delivery, under the condition that notice of the alleged defect to the products or parts thereof be given to Finish Thompson, Inc. within the term of 8 days from the discovery.
5. Repair or replacement under the terms of this warranty shall not give a right to an extension to, or a new commencement of, the period of warranty. Repair or replacement under the terms of this warranty may be fulfilled with functionally equivalent reconditioned units. Finish Thompson, Inc. qualified personnel shall be solely entitled to carry out repair or replacement of faulty parts after careful examination of the motor. Faulty parts or components when replaced by Finish Thompson, Inc. will become the property of Finish Thompson, Inc. If this warranty does not apply, the purchaser shall bear all cost for labor, material and transportation.
6. Finish Thompson, Inc. will not be liable on any claim, whether in contract, tort, or otherwise, for any indirect, special, incidental, or consequential damages, caused to the customer or to third parties, including loss of profits, process down time, transportation costs, costs associated with replacement or substitution products, labor costs, installation or removal costs. In any and all events, manufacturer’s liability shall not exceed the purchase price of the product and/or accessories.
7. Return Policy. Should you have any problems with this product, please contact the distributor in your area. The distributor will determine if a return to the factory is necessary and will contact the factory for a Return Authorization Number.

Safety

Lithium Ion Battery Advantages

The advanced lithium ion batteries contained in the S6 drum pump motor have several major advantages compared to older technologies like nickel cadmium (NiCd) or nickel metal hydride (NiMH).

- They have much higher energy density compared to NiCd or NiMH. This results in a significantly lighter battery. The battery used in the S6 is extremely powerful for its compact size and weight.
- Lithium ion batteries have no “memory” effect. This allows the battery to be recharged at any state of discharge (it does not need to be fully discharged before recharging like other battery technologies).
- Lithium ion batteries are environmentally friendly.

Important Safety Information Battery Chargers

- Before using the charger, read and understand all instructions and product caution labels on the charger and the motor.
- There are two charger options. One version operates on 115/230 volts, 50/60 Hz. There are two versions of the power cord to accommodate plug styles on 115-volt or 230-volt AC outlets. The other version is for use with 12-volt DC charger ports (“cigarette lighter port”) found in automobiles and trucks. Do not attempt to operate the charger on any other than the rated voltage.
- Use the charger **ONLY** with the Finish Thompson S6 drum pump motor. Do not use the charger with any other lithium ion batteries or any other type battery – fire or explosion may occur.
- Never use any other type of charger to recharge the Finish Thompson S6 drum pump motor, as damage to the battery protection circuit may occur.
- Do not allow any liquid to enter the charger.
- The charger must be installed in a dry location.
- The charger may become warm to the touch when charging.
- The required charging time varies with the remaining charge level in the battery pack but a completely discharged battery is fully charged in approximately three hours.
- The longest life and best performance is obtained if the motor is charged when the air temperature is between 65° F (18° C) and 75° F (24° C). **DO NOT** charge the battery pack if the air temperature is below 40° F (5° C) or above 104° F (40° C). This will prevent serious damage to the battery pack.

Battery Safety Information

- Do not incinerate the motor or battery pack contained inside the motor even if it is completely worn out. The battery pack can explode in a fire. Toxic fumes are created when lithium ion batteries are burned.
- Do not use or charge this motor in hazardous locations where flammable vapors or ignitable dust occur.
- Do not immerse in fluid.
- If the battery contents contact the skin, immediately wash the area with mild soap and water. If battery liquid gets into the eye, rinse water over the open eye for 15 minutes or until irritation ceases. If medical attention is required, the battery electrolyte is a mixture of liquid organic carbonates and lithium salts.
- Do not place the motor or the battery pack contained in the motor in areas of high heat (>140° F/60° C) near a heater or fire for example.
- Do not pierce the battery contained inside the motor with any sharp objects.
- Do not subject the battery pack to strong impacts or shocks.
- Never store or charge the motor inside a car or truck in extremely hot weather.
- Do not disassemble or modify the battery pack. The battery contains safety and protection devices which if damaged or disabled may cause the battery to generate excess heat, explode or ignite.

Operation Information

-  **Warning-** Do not use or charge this motor in hazardous locations where flammable vapors or ignitable dust occur.
- The battery pack is not fully charged in a brand new motor. Fully charge the battery before the first use.
- The recommended ambient temperature range for operating the motor is 40° F (4.5° C) to 105° F (40.5° C). Operating the motor below 40° F (4.5° C) will result in reduced battery capacity.

- Never place metal objects in the motor's charging port. A short circuit could occur allowing the motor's battery pack to generate excess heat, explode or ignite.
- The battery can be recharged at any state of battery discharge. It does not have to be completely discharged before charging and does not suffer the "memory effect" found in other battery technologies.
- Long-term storage will not harm the battery pack provided it contains a partial charge. Under proper storage conditions (approximately 68° F/20° C at approximately 30-50% of full charge), the motor can be stored for at least a year without adverse effect.
- For best results, it is recommended that the motor be charged and used at least every twelve months.
- Clean only with a damp cloth.

Battery Disposal

- When the battery in the motor has reached the end of its life and no longer is capable of providing satisfactory results it should be recycled where possible.
- Follow local regulations and ordinances for the disposal of batteries.
- The RBRC (Rechargeable Battery Recycling Corporation) Seal indicates that the costs to recycle the battery pack at the end of its useful life have already been paid for by Finish Thompson. RBRC in cooperation with Finish Thompson and other battery users has established programs in the United States and Canada to facilitate the collection of spent lithium ion batteries. The battery pack will have to be removed from the motor before it can be recycled. See battery pack removal instructions for detailed instructions.



Operator Qualification and Training

The personnel in charge of the installation, the operation and maintenance of the pump unit we produce must be qualified and able to perform the operations described in this manual. Finish Thompson, Inc. shall not be held responsible for the training level of personnel nor for the fact that they are not fully aware of the contents of this manual.

Pumping Safety Instructions

⚠ FOR YOUR OWN SAFETY

BEFORE using or servicing your pump, please make sure to wear the proper clothing, eye protection and follow standard safety procedures when handling corrosive or personally harmful materials.

⚠ GENERAL DANGER

NEVER use a plastic pump or an open, splash-proof (such as the S6 motor), TEFC or non-ATEX motor when pumping or mixing flammable or combustible material. Contact Finish Thompson for suitable models.

ALWAYS use and store the pump and motor in an upright position.

Noise Level

S6 Rechargeable Motor in normal operating conditions produces a sound level equal to or less than 64 dBA at a distance of three feet (~ one meter).

Modifications and Spare Parts

Any changes concerning the service of the motor as originally purchased can be executed only after written approval from Finish Thompson, Inc. It is recommended to use only genuine Finish Thompson, Inc. spare parts and approved accessories. The use of non-original spare parts or non-approved accessories will void warranty and removes any responsibility on our behalf for any damage caused to people or things.

IMPORTANT SAFETY INFORMATION FOR PUMPING FLAMMABLE OR HAZARDOUS SUBSTANCES

Read these instructions before operating the pump and motor equipment. The manufacturer will not be responsible for any damage to property or to persons caused by improper use of the equipment.

- ⚠ WARNING:** It is the responsibility of the user to operate the pump in conformance with OSHA rules for dispensing liquids. Pump containers should be grounded when using with flammable or combustible liquids to avoid static electricity.
1. Use only an explosion-proof rated electric or non-electric (air) motors on stainless steel pump tubes with a Static Protection Kit when transferring flammable or combustible liquids.
- ⚠ WARNING:** Never use an open, splash-proof, TEFC, battery-operated or non-explosion-proof rated motor or a plastic pump tube when transferring flammable or combustible liquids.
2. When operating a drum pump (especially when pumping flammable, combustible or hazardous liquids) follow all electrical and safety codes.
 - a) In the United States: the United States Occupational Safety and Health Act (OSHA), most recent National Electrical Code (NEC), National Fire Protection, Inc. (NFPA) Code 30 (Flammable and Combustible Code), NFPA 77 (Static Electricity), NFPA 251 (Standard Method of fire Test of Building Construction), NFPA 704 (Identification of the Fire Hazards of Materials), and other NFPA codes, local codes and ordinances.
 - b) Outside the United States: the ATEX equipment directive 2014/34/EU where applicable, the ATEX workplace 99/92/EC directive where applicable, in addition the precautions of the U.S. codes listed herein and all other local codes and ordinances.
 3. Pumping hazardous, flammable, or combustible liquids should only be done in buildings, rooms, or areas suited for this purpose. (See NFPA 30, NFPA 78, NFPA 80, NFPA 251, NFPA 704, other suitable NFPA codes, OSHA, ATEX workplace 99/92/EC directive insurance companies, and other local codes and ordinances.)
 4. When filling cans, drums, etc. with combustible or flammable liquids, both container pumping from and container pumping to, should be bonded and grounded to dissipate possible accumulations of static electricity, and minimize sparks caused by static electricity (refer to NFPA 77 and CLC/TR 60079-32-1 for specific details).
- ⚠ WARNING:** Avoid splashing. Splash filling can create static electricity and is extremely hazardous. Reduce motor speed to prevent splashing.
- ⚠ WARNING:** Fluid velocity must be 3 feet/.9 meter/second maximum (7 gpm/26.5 lpm in 1" hose and 4 gpm/15 lpm in ¾" hose) to reduce risk of static electricity. Reduce motor speed to reduce the fluid velocity.
5. Before using, confirm that the pump and any accessories (hose, nozzle, flow meter, etc.) materials of construction are suitable for the material to be pumped and that the maximum temperature is not exceeded.

INFORMATIONS IMPORTANTES SUR LA SÉCURITÉ DURANT LE POMPAGE DE SUBSTANCES INFLAMMABLES OU DANGEREUSES

Veillez lire attentivement ces instructions avant d'utiliser la pompe et l'équipement du moteur. Le fabricant ne sera pas tenu responsable des dommages matériels ou corporels causés par une utilisation inappropriée de l'équipement.

- ⚠ AVERTISSEMENT:** Il est de la responsabilité de l'utilisateur de faire fonctionner la pompe conformément aux règles OSHA (Santé et Sécurité au Travail) relatives à la distribution de liquides. Les conteneurs de pompes doivent être électriquement mis à la terre lors de l'utilisation de liquides inflammables ou combustibles afin d'éviter toute électricité statique.
1. Lors du transfert de liquides inflammables ou combustibles, utilisez uniquement des moteurs électriques ou non électriques (pneumatiques) antidéflagrants sur des tubes de pompe en acier inoxydable dotés d'un dispositif de protection antistatique.
- ⚠ AVERTISSEMENT:** N'utilisez jamais de moteur ouvert, à l'épreuve des éclaboussures, TEFC, alimenté par piles ou non antidéflagrant, ni un tube de pompe en plastique lors du transfert de liquides inflammables ou combustibles.
2. Lors de l'utilisation d'une pompe à tambour (en particulier lors du pompage de liquides inflammables, combustibles ou dangereux), respectez tous les codes électriques et les codes de sécurité.
 - a) Aux États-Unis : Loi américaine sur la sécurité et la santé au travail (OSHA); le code national de l'électricité (NEC) le plus récent; le code 30 de la NFPA (code d'inflammabilité et de produits combustibles); le code NFPA 77 (électricité statique); le code NFPA 251 (Méthode standard de test d'incendie de la construction de bâtiments); le code NFPA 704 (Identification des risques d'incendie des matériaux) et autres codes et règlements de la NFPA.
 - b) En dehors des États-Unis : La directive sur les équipements ATEX 2014/34 / EU, le cas échéant, la directive ATEX sur le lieu de travail 99/92 /EC, le cas échéant, ainsi que les précautions des codes des États-Unis énumérés dans la présente et de tous les autres codes, lois et règlements locaux.
 3. Le pompage de liquides dangereux, inflammables ou combustibles ne doit être effectué que dans des bâtiments, des pièces ou des zones adaptées à cet usage. (Voir NFPA 30, NFPA 78, NFPA 80, NFPA 251, NFPA 704, autres codes NFPA appropriés, OSHA, les directives des compagnies d'assurance ATEX 99/92 /CE, et autres codes, lois et règlements locaux.)
 4. Lors du remplissage de bidons, fûts, etc. avec des liquides combustibles ou inflammables, les conteneurs d'où le liquide est pompé et le conteneur recevant le liquide doivent être reliés et mis à la terre pour éviter toute accumulation éventuelle d'électricité statique et minimiser ainsi les étincelles causées par l'électricité statique (voir NFPA 77). et CLC / TR 60079-32-1 pour des détails spécifiques).
- ⚠ AVERTISSEMENT:** Évitez les éclaboussures. Les éclaboussures peuvent créer de l'électricité statique et sont extrêmement dangereuses. Réduisez la vitesse du moteur pour éviter les éclaboussures.
- ⚠ AVERTISSEMENT:** La vitesse du fluide doit être au maximum de 3 pieds / 0,9 mètre / seconde (7 gpm / 26,5 lpm dans un tuyau de 1"; et 4 gpm / 15 lpm dans un tuyau de ¾") afin de réduire le risque d'électricité statique. Réduisez la vitesse du moteur afin de réduire ainsi la vitesse du fluide.
5. Avant utilisation, assurez-vous que les matériaux de la pompe et des accessoires (tuyau, ajustage, débitmètre, etc.) sont compatibles avec le fluide et que la température maximale n'est pas dépassée.

Installation

1. Unpack motor and pump tube from carton. Check for shipping damage. If damage is detected, save the packaging and notify the carrier immediately.
2. If motor and pump tube are boxed separately, the motor will need to be fastened to the pump tube. **See figure 1.**
3. Place the motor upside down on a tabletop surface with the coupling facing upwards and place the yellow coupling insert (item 1) from the pump manual onto the motor's coupling. **See figure 2.**
4. Position the pump tube upside down onto the motor. Align the discharge spout of the pump facing away from the handle of the motor. **See figure 3.**



Figure 1



Figure 2

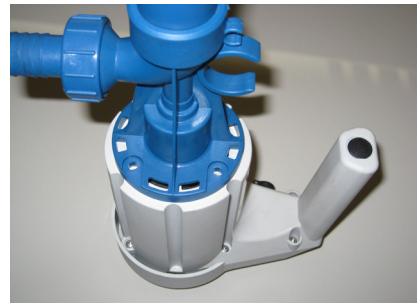

Figure 3

5. Firmly press the pump tube onto the motor until it lays flat. A slight twist may be necessary for the coupling splines to line up properly. **See figure 4.**
6. Align the 4 bolt holes in the pump to the 4 holes in the motor, and fasten with 4 pieces (item 7) flat washer and 4 pieces # 8 Screw (item 8) from the pump manual using a # 2 Philips head screwdriver. Note: The EFS (316SS) model does not use the 4 pieces of (item 7) flat washers. Hand-tighten, being careful not to over-torque and strip the plastic. **See figure 5.**



Figure 4



Figure 5

7. Using a SS hose clamp, secure a $\frac{3}{4}$ " ID chemically compatible reinforced hose to the discharge spout of the pump.

Motor Operation

Note: The motor has been partially charged and should be fully charged prior to use.

Warning: The motor is NOT suitable for hazardous locations or pumping flammable or combustible materials.

1. Verify that the motor switch is in the center “O” OFF position. **See Figure 6.**



Figure 6

2. Insert the pump tube into the fluid to be dispensed and the hose in the container to be filled.
3. While holding the motor handle and hose, switch the motor to the “I” low speed. The fluid will begin to pump.
4. If more flow is desired, switch the motor to the “II” high speed setting.

Note: Performance will diminish a small amount as the battery loses its charge. When the battery reaches a low charge level it will simply stop. This is normal. Battery will need to be charged at this point.

Charger Operation

The lithium ion battery contained in the motor is extremely powerful for its compact size and weight. It does not suffer “memory” issues like other types of batteries. It can be placed on the charger in any state of discharge (it does not need to be fully discharged like other battery types).

Note: Do not charge or operate the motor if the ambient temperature is below 41° F (5° C) or above 104° F (40° C). The charger is designed for dry locations.

1. Plug the supplied charger into a suitable outlet (115 volt, 1phase, 50/60 Hz), (230 volt, 1phase, 50/60 Hz) or (12 volt, car or truck).

2. Charger Indicator Lights:

115/230V charger

- Green: Power supplied to charger, or fully charged when motor is connected.
- Red: Charging.
- No Light: No power, faulty charger or faulty motor.

12V car charger

- Green: Power supplied to charger or fully charged when motor is connected.
- Red: Charging.
- No light: No power, faulty charger, or faulty motor.

3. Gently open the jack cover. Note cover only opens 90°. Opening it more will damage the cover & it will need to be replaced in order to properly protect the jack. Jack is located on side of motor near ON/OFF switch. **See figure 7.**



Figure 7

4. With the motor in the “O” off position, insert the charging cord plug into the jack (The jack is coated with anti-corrosion grease from the factory.) The motor is fully charged when the small indicator light on the charger turns from red to green. The charge cycle time varies depending upon the level of battery discharge. If the battery is completely discharged it will take approximately 3 hours to reach full charge.

Note: Motor will not operate while connected to the charger.

Battery Pack Removal for Recycling

If your battery pack will no longer hold a charge, you can either purchase a replacement battery pack or a new S6 motor assembly. To recycle your old battery pack, please follow these instructions:



1. Make sure the motor switch is in the OFF position before beginning.
2. Remove the 6-high-low screws (item 5) from the motor cover (item 1) & lift off. **See Figure 8.**
3. Remove red & black motor lead wires from the motor terminals one at a time. **See Figure 9. Warning:** Do Not allow wires to touch. To prevent a short circuit & battery overheating, tape over the terminals with electrical tape immediately upon removal.



Figure 8

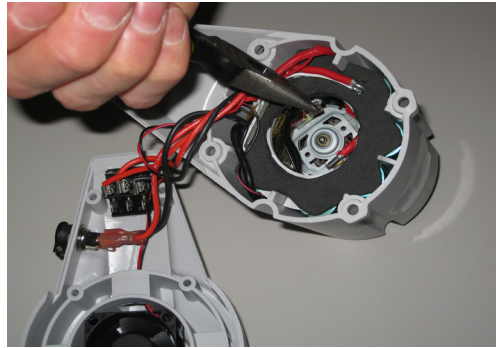

Figure 9

4. Pull the battery pack (item 2) from the motor canister (item 4) using 2 fingers inserted into the middle of the battery pack. **See Figure 10.**
5. Cut all wires attached to the battery pack one at a time. **See Figure 11.** Battery pack is now ready to be taken to a recycling center.

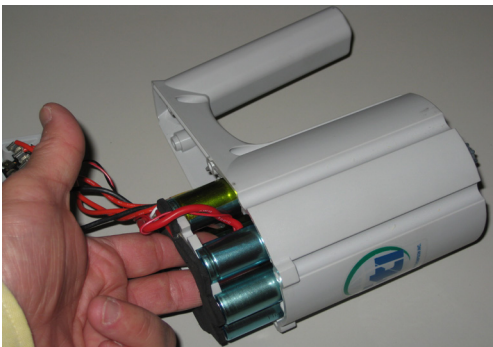

Figure 10



Figure 11

Troubleshooting

- If the motor trips off while pumping, it is being overloaded or battery is dead. To reset the motor, press the switch to the "O" off position and then back to ON position. If the motor does not restart after being reset the battery requires recharging.
- Increasing the flow rate may be a solution for persistent motor tripping. Persistent motor tripping can also be reduced by running at a reduced voltage (partially discharged battery).
- Lithium Ion battery packs do not slow down as the pack becomes depleted they will simply stop pumping suddenly. This is normal. Battery will need to be recharged.
- Using a discharge hose greater than 5 ft (1.5M) long or a discharge nozzle can reduce the maximum volume of liquid pumped per charge.
- If the charger indicator light fails to illuminate, make sure the charger is plugged into a working outlet or vehicle power port.
- If the charger indicator light fails to turn green after more than 4 hours check the motor charging jack for corrosion. If corroded replace the charging jack.

Wall Hanger Instructions



Figure A



Figure B

If you ordered the optional Wall Hanger p/n 108287 or received it in one of our kits please follow these instructions for installation & use:

1. If using the 115v or 230v Quick Charger you may store it inside the Wall Hanger. Simply align the charger cables with the slots on the wall hanger making sure the indicator light lines up with the hole on the front of the wall hanger. Slide the charger into place. Charger cord plug may be stored in the slot on the right side of the Wall Hanger. **See Figure A.** Note: Wall Hanger may also be used with other EF electric & air operated motors.

2. The Wall Hanger comes with 4-#10 x 2-1/2" Phillip head screws for attaching to a wall. If longer screws are needed make sure to use the same diameter so as not to damage the wall hanger. Suggest using a piece of 1/2" or 5/8" plywood to install the Wall Hanger to a wall. If not available you may attach it to a wooden stud. Care should be taken to align the center of the Wall Hanger with the center of the stud so all 4 screws can be used. If mounting to Drywall use proper drywall fastening hardware. If mounting to a brick or cement wall you may use 3/16" x 2-1/4" Tapcon screws. Pre-drill with a 5/32" masonry drill bit using the Wall Hanger as a guide for screw holes.

⚠ Caution: Wall Hanger must be level to properly hold the motor & pump and prevent damage. Care should also be taken to **not over-tighten** screws or damage could be done to the Wall Hanger.

3. Pump & motor can now be installed on the Wall Hanger. See above figure B.

Technical Data

Motor Specifications	
Rechargeable Motor (2 speed)	
Specifications	Model S6
Battery Voltage	12 volts* (10.8 volts)
Battery Capacity/Type	5,000 mAh/Lithium Ion
Input/Output Power	150/100 Watts
Duty Cycle	Continuous
RPM (low/high speed)	8,000/12,000
Maximum Flow	14 gpm(53 lpm) @ high speed
	8 gpm (30 lpm) @ low speed
Maximum Head	13 ft (4 m) @ high speed
	7 ft (2 m) @ low speed
Maximum Viscosity	100 cP @ high speed
	25 cP @ low speed
Maximum Specific Gravity	1.2 @ high speed
	1.6 @ low speed
Approximate Run Time Between Charges	30 minutes @ high speed
	75 minutes @ low speed
Maximum Fluid Pumped on Full Charge	750 gal (2,800 l) @ high speed
	400 gal (1,500 l) @ low speed
Enclosure	Splashproof, IP24
Certifications/Approvals	CE

*Maximum initial voltage is 12 volts. Under workload, nominal voltage is 10.8.

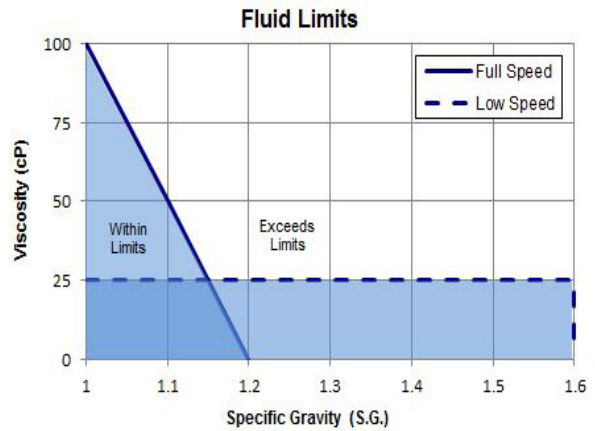
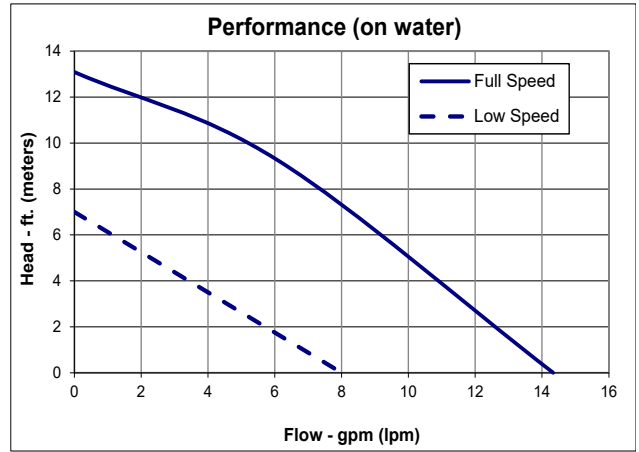

Maximum Performance Limits				
High Speed Motor Setting	If specific gravity is:	viscosity can not exceed:	Max. Flow gpm (lpm)	Max. Head ft (m)
	1.0	100 cP	3 (11.4)	14 (4.3)
	1.1	50 cP	7 (26.5)	11(3.4)
	1.2	1 cP	12 (45.4)	9 (2.7)
Low Speed Motor Setting	If specific gravity is:	viscosity can not exceed:	Max. Flow gpm (lpm)	Max. Head ft (m)
	up to 1.6	25 cP	6 (22.7)	3 (0.9)



MODEL: S6
PART NO: 107951
SERIAL NO: 123456 G22
 U.S. Patent No. 9,273,697
10.8V ===
54 Wh
5000 mAh
IP24
DATE OF MFG: 01/31/23



WARNING: THIS EQUIPMENT IS NOT EXPLOSION PROOF
DO NOT use this equipment in or near flammable or combustible liquids!
DO NOT submerge this motor in fluid!
DO wear eye and skin protection.
DO read proper operation and safety precautions in instruction manual.
ONLY charge w/ F.T.I. Li-Ion Charger.

CAUTION: Do not expose to temperatures above 104°F (40°C).



DO NOT STORE UPSIDE DOWN.

S6 Sample Label

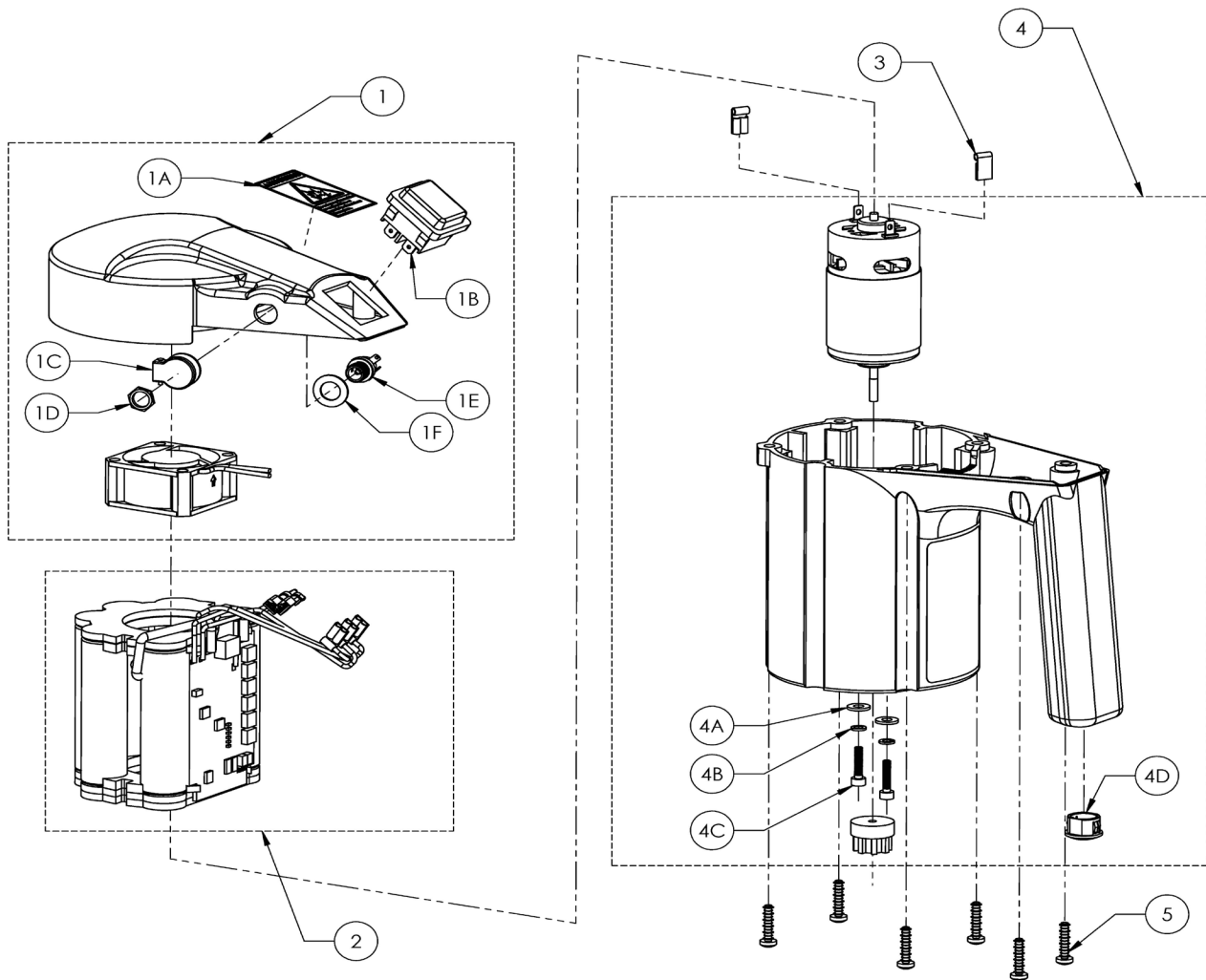

Item	Quantity	Description	Part Number
1	1	Motor cover & fan assembly	108301
1A	1	Flammables warning label	108148
1B	1	Switch	107304
1C	1	Jack cover	108219
1D	1	Jack nut	108220
1E	1	DC power jack	107958
1F	1	Stainless steel flat washer	107974
2	1	Battery pack assembly	108302
3	2	Flag terminal	107972
4	1	Motor & canister assembly	108300
4A	2	Stainless steel flat washer	107125
4B	2	Stainless steel lock washer	107141
4C	2	Stainless steel socket head cap screw	107973
4D	1	Hole plug	107956
5	6	Stainless steel hi-low screw	J101020



FINISH THOMPSON INC.

921 Greengarden Road • Erie, PA 16501-1591 U.S.A.