

ENGINEERING
TOMORROW

Danfoss

Product Catalog

Vickers® by Danfoss

Proportional two-stage directional valves
high performance with main stage spool feedback

KBFDG5V-5/7/8/10 Series
Pressures to 350 bar (5000 psi)

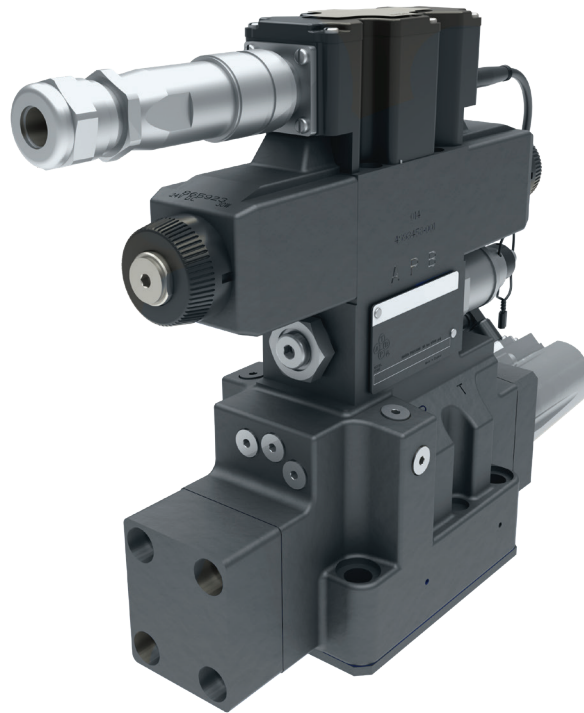

VICKERS
by Danfoss

Contents

General Description	Page 3
Typical Section	Page 3
Model Codes	Page 4
Spool Data	Page 6
Operating Data	Page 8
Performance Characteristics	Page 10
Installation Dimensions	Page 13
Mounting Surfaces	Page 15
Electrical Information	Page 18
Application Data	Page 21



This product has been designed and tested to meet specific standards outlined in the European Electromagnetic Compatibility Directive (EMC) 89/336/EEC, amended by 91/263/EEC, 92/31/EEC and 93/68/EEC, article 5. For instructions on installation requirements to achieve effective protection levels, see this leaflet and the Installation Wiring Practices for Vickers™ Electronic Products leaflet 2468. Wiring practices relevant to this Directive are indicated by  Electromagnetic Compatibility (EMC).

Introduction

General description

Vickers by Danfoss proportional valves shown in this catalog are suitable for working pressures up to 350 bar (5000 psi) and flow rates to 375 l/min (99 USgpm). They are designed to provide a controlled oil flow in proportion to a command signal, with spool position feedback to provide accurate control.

KBFDG5V-5/7/8/10

A range of proportional directional valves with control amplifiers built directly on, and prewired to the valves. Factory-set adjustments of gain, spool deadband compensation, and offset ensure high valve-to-valve reproducibility.

The only electrical inputs required are power supply (24V) and a command signal of $\pm 10V$ or 4-20 mA. The amplifier is housed in a robust metal enclosure, sealed against ingress of water and other fluids. Electrical connections are via a standard 7-pin plug.

A spool position monitor point is included which allows the function of the valve to be monitored, if required.

Features and Benefits

- Factory-sealed adjustments increase valve-to-valve reproducibility.
- Valve with integrated amplifier selected, ordered, delivered and installed as one performance-tested package.
- Electronic feedback LVDT ensures accurate spool position control.
- Vibration and shock tested.
- Standard 24V DC supply with wide tolerance band.
- Wide range of spool and flow rate options.
- Standard $\pm 10V$ DC or 4-20 mA command signals.
- Installation wiring reduced and simplified.
- Standard 7-pin connector.
- Simple valve removal and replacement for service.
- Supported by auxiliary function modules.
- Full CE/UKCA electromagnetic compatibility.
- IP65 and IP67 environmental protection rating.
- Optional valve enable function.
- Failsafe feature.

Typical section view

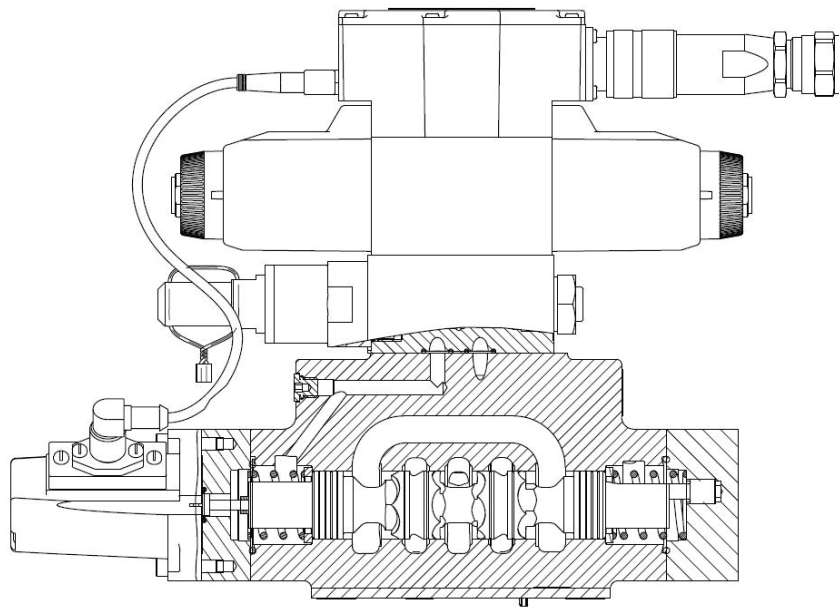

KBFDG5V-7, 20 DESIGN

Model Codes

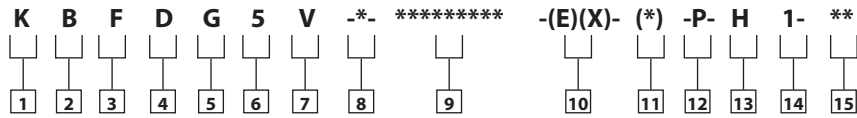

1	Valve Type	K Proportional valve
2	Integral amplifier	B Integral amplifier "B" Series
3	Feed back arrangement	F From main stage
4	Control Type	D Directional valve
5	Mounting	G Subplate mounted
6	Operation	5 Solenoid controlled, pilot operated
7	Pressure rating	V 315 bar (4500 psi) Size 05 350 bar (5000 psi) Size 07 350 bar (5000 psi) Size 08 350 bar (5000 psi) Size 10
8	Mounting Interface Size (ISO 4401)	5 Size 05 7 Size 07 8 Size 08 10 Size 10

9 **Spool Type, flow rating and metering**
See "Functional Symbol" on page 5. p = 5 bar (72psi) per metering flow path, e.g. B to T.

Symmetric Spools

For KBFDG5V-5 valves

2C95N	100 L/min (26 US gpm)
33C80N	80 L/min (21 US gpm)

For KBFDG5V-7 valves

2C230N	230 L/min (59.8 US gpm)
33C230N	230 L/min (59.8 US gpm)
35C200F	200 L/min (52.84 US gpm)
36C185N	185 L/min (48.1 US gpm)

For KBFDG5V-8 valves

2C375N	375 L/min (99 US gpm)
33C375N	375 L/min (99 US gpm)

For KBFDG5V-10 valves

2C700N	700 L/min (185 US gpm)
33C700N	700 L/min (185 US gpm)

Asymmetric Spools

First figure (**N) is flow rating P-A, or A-T ("A" port flow); last figure (N**) is flow rating P-B, or B-T ("B" port flow)

For KBFDG5V-5 valves

2C70N45	70 L/min (18.5 USgpm), "A" port flow 45 L/min (11.9 USgpm), "B" port flow
33C60N40	60 L/min (17.2 USgpm), "A" port flow 40 L/min (10.6 USgpm), "B" port flow
2C90N60	90 L/min (20.8 US gpm), "A" port flow 60 L/min (15.6 US gpm), "B" port flow

For KBFDG5V-7 valves

2C150N85	150 L/min (40 US gpm), "A" port flow; 85 L/min (22.4 US gpm), "B" port flow
2C230N140	230 L/min (59.8 US gpm), "A" port flow, 140 L/min (36.4 US gpm), "B" port flow
33C230N140	230 L/min (59.8 US gpm), "A" port flow, 140 L/min (36.4 US gpm), "B" port flow

For KBFDG5V-8 valves

2C375N250	375 L/min (99 US gpm), "A" port flow; 250 L/min (66 US gpm), "B" port flow
12C375N250	375 L/min (99 US gpm), "A" port flow; 250 L/min (66 US gpm), "B" port flow
33C375N250	375 L/min (99 US gpm), "A" port flow; 250 L/min (66 US gpm), "B" port flow
133C375N250	375 L/min (99 US gpm), "A" port flow; 250 L/min (66 US gpm), "B" port flow
733C375N250	375 L/min (99 US gpm), "A" port flow; 250 L/min (66 US gpm), "B" port flow
72C375N250	375 L/min (99 US gpm), "A" port flow; 250 L/min (66 US gpm), "B" port flow

For KBFDG5V-10 valves

2C700N420	700 L/min (185 US gpm), "A" port flow; 420 L/min (110 US gpm), "B" port flow
33C700N420	700 L/min (185 US gpm), "A" port flow; 420 L/min (110 US gpm), "B" port flow
12C700N420	700 L/min (185 US gpm), "A" port flow; 420 L/min (110 US gpm), "B" port flow
133C700N420	700 L/min (185 US gpm), "A" port flow; 420 L/min (110 US gpm), "B" port flow
72C700N420	700 L/min (185 US gpm), "A" port flow; 420 L/min (110 US gpm), "B" port flow
733C700N420	700 L/min (185 US gpm), "A" port flow; 420 L/min (110 US gpm), "B" port flow

Model Codes (cont.)

For actual maximum flows refer to power capacity envelopes, page 8.

10	Pilot Supply	
	X	Internal
	EX	External (Pilot Drain - External ONLY)
11	Control signal	
	M1	±10V
	M2	4-20mA
12	Electrical connection	
	PC7	7 pin connector without plug
	PE7	7 pin connector with plug
	PH7	As PE7 but with pin "C" used for enable signal
	PR7	As PC7 but with pin "C" used for enable signal
13	Coil rating	
	H	24VDC amplifier supply
14	Pilot drain port	
	1	4 bar (58 psi)
15	Design Number	
	11	Subject to change. Installation dimensions unaltered for design numbers 10 to 19 respectively. Design 2* only for KBFDG5V-7
	2*	



Warning

Valves with integral amplifiers are supplied with or without the metal 7-pin plug. The Vickers plug, part no. 934939, must be correctly fitted to ensure that the EMC rating and IP67 rating are achieved. The plug retaining nut must be tightened with a torque of 2-2,5 Nm (1.5-2.0 lbf ft) to effect a proper seal.

Spool Data

Spool symbols

Functional symbol

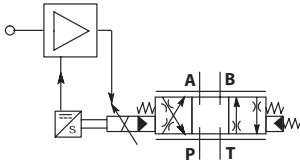

Simplified symbol

Application notes

A. Main-spool options

Spools shown are meter-in/ meter-out types. Center condition options are types 2, 33, 12, 133, 72, 733, 35, 36 and 535

B. Internally piloted models

Differ from detailed symbols above by omission of plug A and the locking of port X by the mating surface.

Spool type and flow ratings

Symmetric spools

Base line pressure drop $\Delta p = 5$ bar (72 psi) per metering flow path, e.g. B to T. For actual maximum flow refer to power capacity envelope curves.

Asymmetric spools

Figure preceding metering type designator, "N" e.g.

2C**N) is flow rating P-A, or A-T ("A" port flow):

Figure after "N" (N***) is flow rating P-B, or B-T

("B" port flow).

Available spools for KBFDG5V

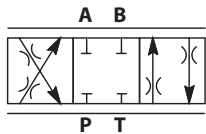

Spool type 2C

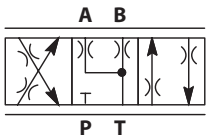

Spool type 33C

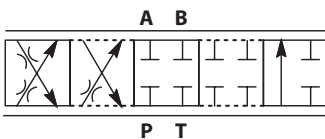

Spool type 12C

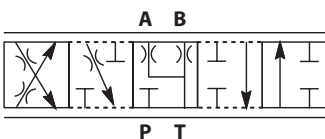

Spool type 133C

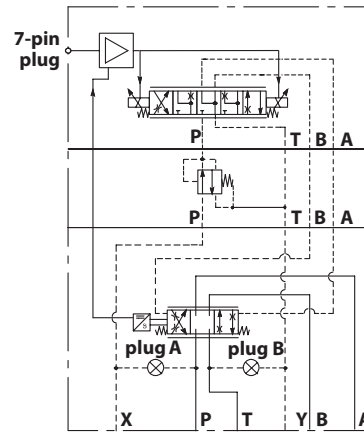

Detailed Symbol

Symmetric

SPOOL CODE	SPOOL SYMBOL	FLOW RATING
For KBFDG5V-5 valves:		
2C95N	2C	95 L/min (25 USgpm)
33C80N	33C	80 L/min (21 USgpm)
For KBFDG5V-7 valves:		
2C230N	2C	230 L/min (59.8 US gpm)
33C230N	33C	230 L/min (59.8 US gpm)
35C200F	35C & 36C	200 L/min (52.84 US gpm)
36C185N	35C & 36C	185 L/min (48.1 US gpm)
For KBFDG5V-8 valves:		
2C375N	2C	375 L/min (99 USgpm)
33C375N	33C	375 L/min (99 USgpm)
For KBFDG5V-10 valves:		
2C700N	2C	700 L/min (185 USgpm)
33C700N	33C	700 L/min (185 USgpm)

Asymmetric Spools

SPOOL CODE	SPOOL SYMBOL	FLOW RATING
For KBFDG5V-5 valves:		
2C70N45	2C	70 L/min (18.5 USgpm), "A" port flow 45 L/min (11.9 USgpm), "B" port flow
33C60N40	33C	60 L/min (17.2 USgpm), "A" port flow 40 L/min (10.6 USgpm), "B" port flow
2C90N60	2C	90 L/min (20.8 USgpm), "A" port flow 60 L/min (15.6 USgpm), "B" port flow
For KBFDG5V-7 valves:		
2C150N85	2C	150 L/min (40.0 USgpm) "A" port flow 85 L/min (22.4 USgpm), "B" port flow
2C230N140	2C	230 L/min (59.8 USgpm), "A" port flow 140 L/min (36.4 USgpm), "B" port flow
33C230N140	33C	230 L/min (59.8 USgpm), "A" port flow 140 L/min (36.4 USgpm), "B" port flow
For KBFDG5V-8 valves:		
2C375N250	2C	375 L/min (99 USgpm) "A" port flow 250 L/min (66 USgpm) "B" port flow
33C375N250	33C	375 L/min (99 USgpm) "A" port flow 250 L/min (66 USgpm) "B" port flow
12C375N250	12C	375 L/min (99 USgpm) "A" port flow 250 L/min (66 USgpm) "B" port flow
133C375N250	133C	375 L/min (99 USgpm) "A" port flow 250 L/min (66 USgpm) "B" port flow
72C375N250	72C	375 L/min (99 USgpm) "A" port flow 250 L/min (66 USgpm) "B" port flow
733C375N250	733C	375 L/min (99 USgpm) "A" port flow 250 L/min (66 USgpm) "B" port flow

Spool Data

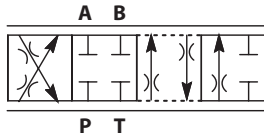

Spool type 72C

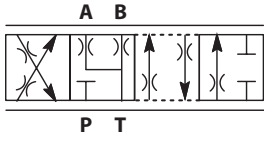

Spool type 733C

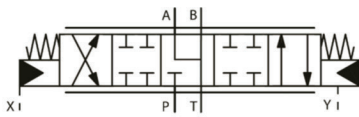

Spool type 35C and 36C

Asymmetric Spools (Cont.)

SPOOL CODE	SPOOL SYMBOL	FLOW RATING
For KBDG5V-10 valves:		
2C700N420	2C	700 L/min (185 USgpm) "A" port flow 420 L/min (110 USgpm) "B" port flow
33C700N420	33C	700 L/min (185 USgpm) "A" port flow 420 L/min (110 USgpm) "B" port flow
12C700N420	12C	700 L/min (185 USgpm) "A" port flow 420 L/min (110 USgpm) "B" port flow
133C700N420	133C	700 L/min (185 USgpm) "A" port flow 420 L/min (110 USgpm) "B" port flow
72C700N420	72C	700 L/min (185 USgpm) "A" port flow 420 L/min (110 USgpm) "B" port flow
733C700N420	733C	700 L/min (185 USgpm) "A" port flow 420 L/min (110 USgpm) "B" port flow

Operating Data

Data is typical with fluid at 36 cSt (168 SUS) and 50°C (122°F).

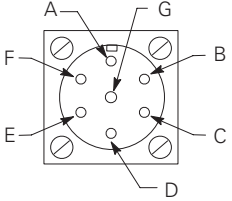
Power supply	24V DC (21V to 36V including 10% peak-to-peak ripple) maximum current - 3A			
Command signal				
Voltage mode (M1)	0 to +10V DC, or 0 to -10V DC, or -10V to +10V DC			
• Input impedance	47 kΩ			
• Maximum voltage Pin D or E to B	18V			
• Minimum voltage Pin D or E to B	-18V			
Current mode (M2)	4-20 mA			
• Input impedance	100Ω			
Valve enable signal for model codes PH7 & PR7:				
Enable	>8.5V (36V max)			
Disable	<6.5V			
Input impedance	10 kΩ			
7-pin plug connector	Pin	Description		
	A	Power supply positive (+)		
	B	Power supply 0V		
	C	Not Connected (PE & PC)		
	C	Valve enable (PH & PR)		
	D	Command signal (+)-non-inverting input, or current input		
	E	Command signal (-)-inverting input, or current output		
	F	Monitor output		
G	Protective ground			
View of pins of fixed half				
Electromagnetic compatibility (EMC):	IEC 61326-2-1 (Electrical equipment for measurement, control and laboratory use) Conducted Emissions CISPR11 -2015-06 Ed 6.0/EN55011 - Class A, 150KHz - 30KHz Radiated Emissions CISPR11 -2015-06 Ed 6.0/EN55011 - Class A, 30MHz - 1GHz RF Continuous Conducted disturbances IEC 61000-4-6, 3Vrms Class A 150 KHz to 80MHz RF Electromagnetic Field, 80MHz to 1GHz, 10V/m; 1.4GHz to 2.7GHz, 3V/m; Meets Criterion A Surge: IEC 61000-4-5 • DC Power Port: +/- 500V • Signal Control Port: +/-1kV Electrical Fast Transients IEC 61000-4-4, Class B • DC Power Port: +/- 1kV • Signal Control Port: +/- .5kV Electrostatic discharges (ESO) IEC 61000-4-2, Class B • Air +/-8kV • Contact +/- 4kV			
ROHS Compliance:	Complies with Restriction of Hazardous Substances (ROHS) Directive 2011/65/EU			
Threshold command voltage (minimum voltage for minimum flow)	0.25V- 2C & 33C Spools			
Monitor signal (pin F)	±4.8 - ±9.5VDC			
Output impedance	10 kΩ			
Power stage PWM frequency	1.2 kHz nominal			
Step input response, with flow through P-A-B-T, Δp=5 bar (72 psi) per metering path, e.g. P-A	Time to reach 90% of required step: KBF DG5V-5 KBF DG5V-7 KBF DG5V-8 KBF DG5V-10			
Required flow step (with reducing module):				
0 to 100%	47 ms	52 ms	84 ms	130 ms
100% to 0	30 ms	36 ms	58 ms	150 ms
+90 to -90%	46 ms	52 ms	88 ms	170 ms
Reproducibility, valve-to-valve (at factory settings):				
Flow at 100% command signal	≤5%			
Hysteresis with flow through P-A-B-T				
Δp=5 bar (72 psi) per metering path (P-A or B-T)	<1%			
Protection:				
Electrical	Reverse polarity protected			
Environmental	IEC 60529, Class IP67			
Ambient air temperature range for full performance	0°C to 70°C (32°F to 158°F)			
Oil temperature range for full performance	0°C to 70°C (32°F to 158°F)			
Minimum temperature at which valves will work at reduced performance	-20°C (-4°F)			
Storage temperature range	-25°C to +85°C (-13°F to +185°F)			

Operating Data (Cont.)

Relative duty factor	Continuous rating (ED = 100%)
Auxiliary electronic modules (DIN -rail mounting):	
EHD-DSG-201-A-1* command signal generator	See catalog GB 2470
EHA-PID-201-A-20 PID controller	See catalog GB 2427
Mass: Valves with pressure reducing	
KBFDG5V-5	9,9 kg (21.8 lb) approx.
KBFDG5V-7	11.6 kg (23.1 lb) approx.
KBFDG5V-8	17,1 kg (37.6 lb) approx.
KBFDG5V-10	43,9 kg (96.5 lb) approx.

Pressure and Minimum Flow Rates

Maximum Pressures, bar (psi) For models with pressure reducer

Model	Pilot pressure source †	Pilot drain connection	P Port	A&B Ports	T Port	X Port	Y Port
KBFDG5V-5	External	To Port Y	315 (4500)	315 (4500)	210 (3000)	315 (4500)	4 (58)
	Internal	To Port Y	315 (4500)	315 (4500)	210 (3000)	315 (4500)	4 (58)
KBFDG5V-7/8/10	External	To Port Y	350 (5000)	350 (5000)	350 (5000)	350 (5000)	4 (58)
	Internal	To Port Y	350 (5000)	350 (5000)	350 (5000)	350 (5000)	4 (58)

Minimum recommended flow rates

Valve size/spool code	Min. Flow rate L/min	In3/min	
KBFDG5V-5-2C100N	0,5	30	For spool types 2C and 33C $\Delta p = 10$ bar (142 psi) for looped flow P-A-B-T (or P-B-A-T)
KBFDG5V-5-33C80N	0,5	30	
KBFDG5V-7-2C200N	1,0	60	
KBFDG5V-7-33C160N	1,0	60	
KBFDG5V-8-2C375N	1,5	91	
KBFDG5V-8-33C375N	1,5	91	
KBFDG5V-10-2C700N	3,0	182	
KBFDG5V-10-33C700N	3,0	182	

Performance curves

KBFDG5V-5/7/8/10

Flow gain

At $\Delta p = 5$ bar (72 psi) per metering path (e.g. P-A), with flow through P-A-B-T or P-B-A-T. Percentage command signals applicable for positive and negative values of command signal.

At other Δp values, flow rates approximate to: $Q_x = Q_D \sqrt{\frac{\Delta p_x}{\Delta p_D}}$
 where Q_D = Datum flow rate
 Δp_D = Pressure drop at datum flow rate
 Δp_x = Required Δp

Limited by valve power capacity. Refer to performance curves.

Power capacity envelope

Flow through P-A-B-T or P-B-A-T

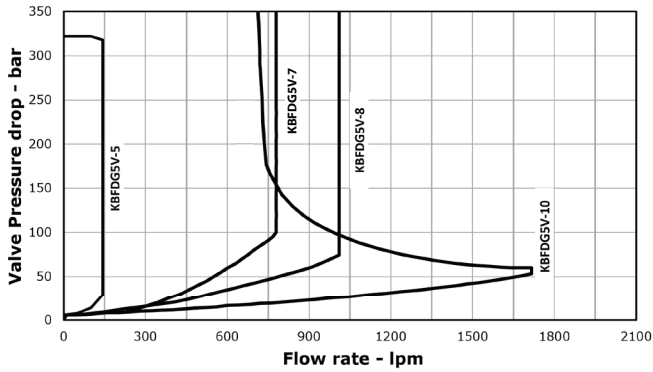

"2C" Spools

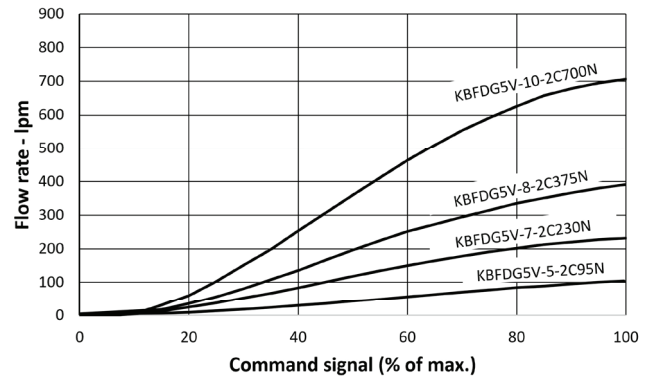

Frequency response, typical

For an amplitude of $50 \pm 25\%$ of rated flow (ISO-10770-1)
 2C spool measured at $v = 36$ cSt (168 SUS),
 $t = 50^\circ$ C (122° F) and pilot pressure = 40 bar.

"2C" Spools

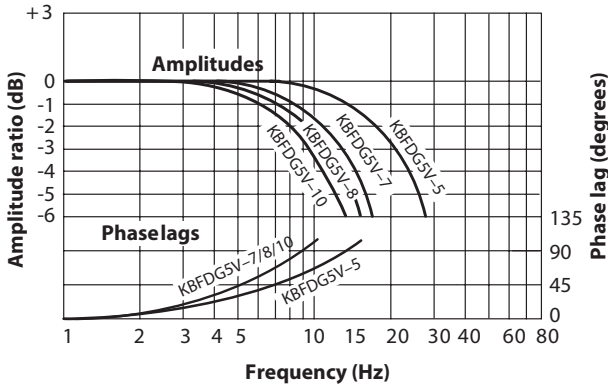

"33C" Spools

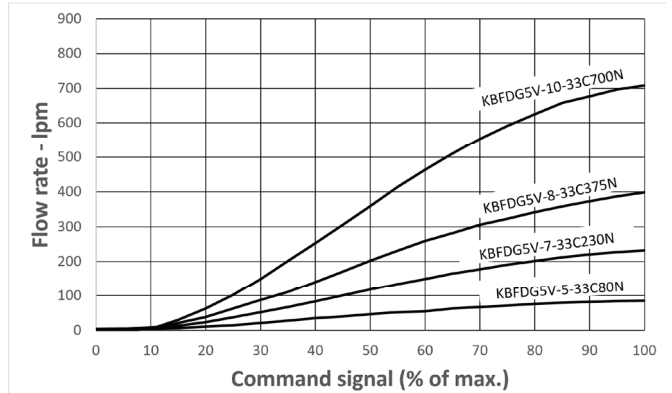

35C200F

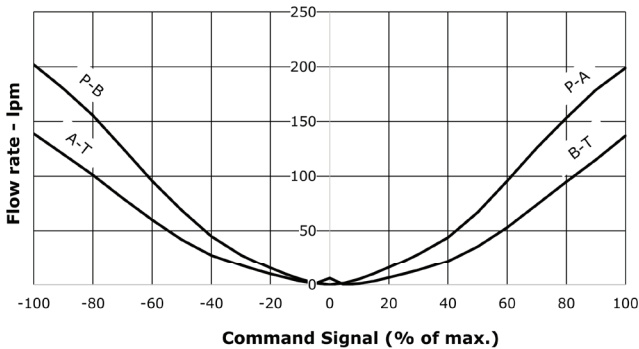

36C185N

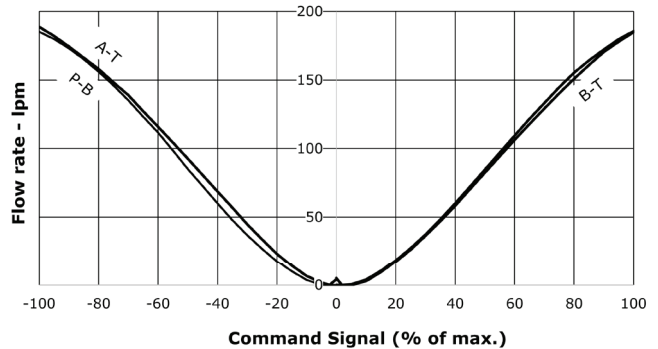

Performance Curves

Flow gain

Asymmetric Spools

KBFDG5V-5

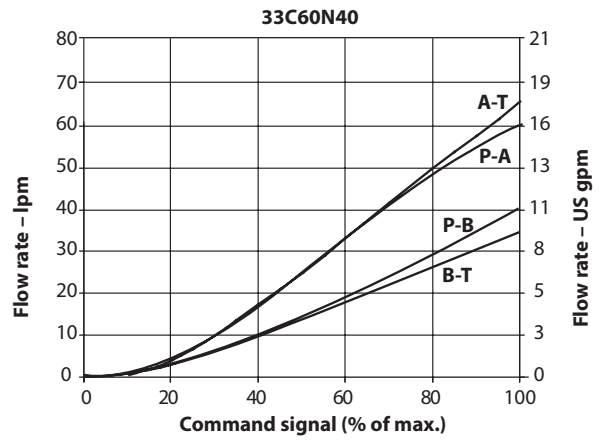
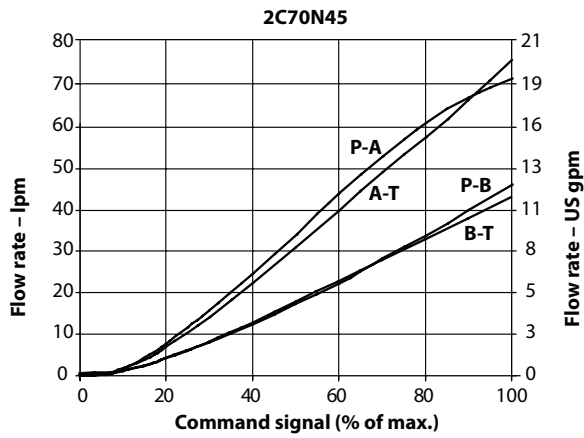

KBFDG5V-7

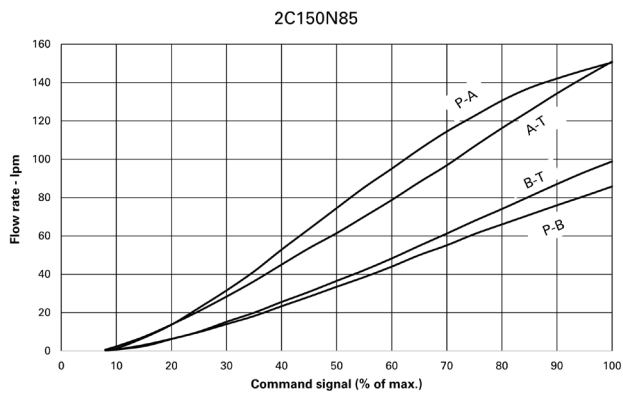
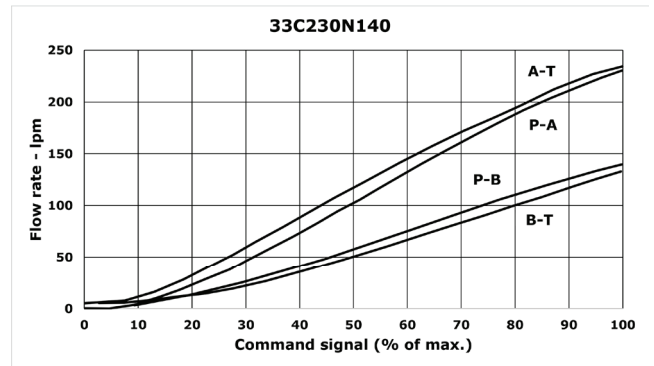
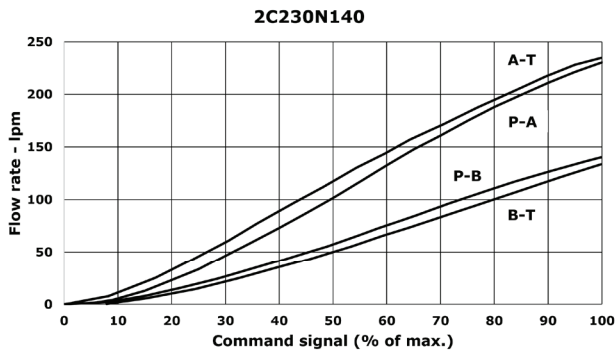

Performance Curves

KBFDG5V-8/10

KBFDG5V-8

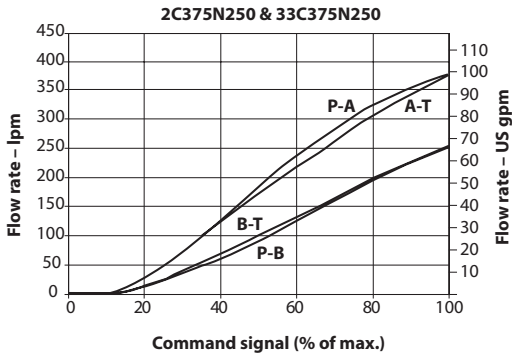

KBFDG5V-10

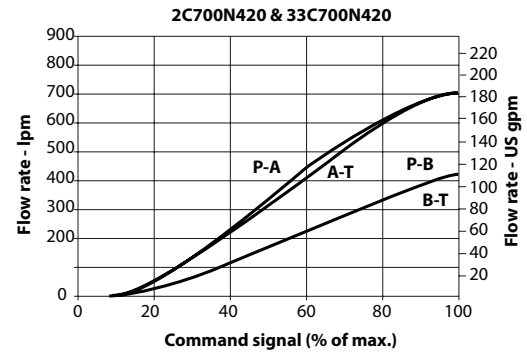

12C375N250 & 133C375N250

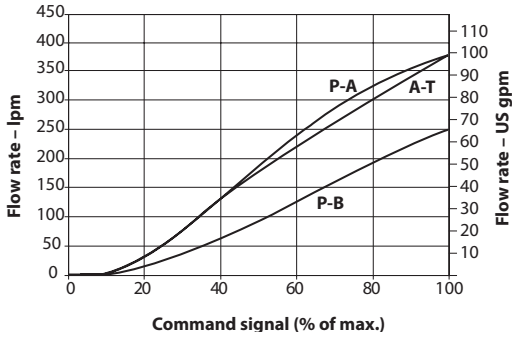

12C700N420 & 133C700N420

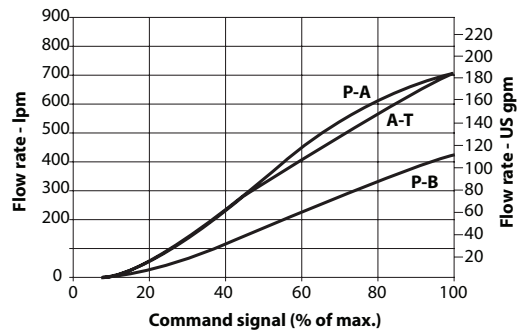

72C375N250 & 733C375N250

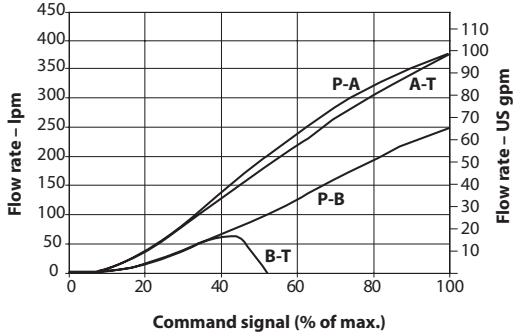

72C700N420 & 733C700N420

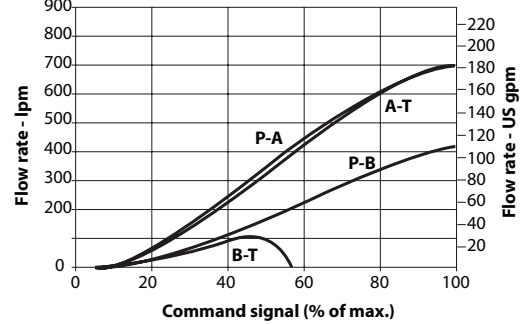

Installation Dimensions

KBFDG5V-5, KBFDG5V-7

KBFDG5V-5

mm (Inch)

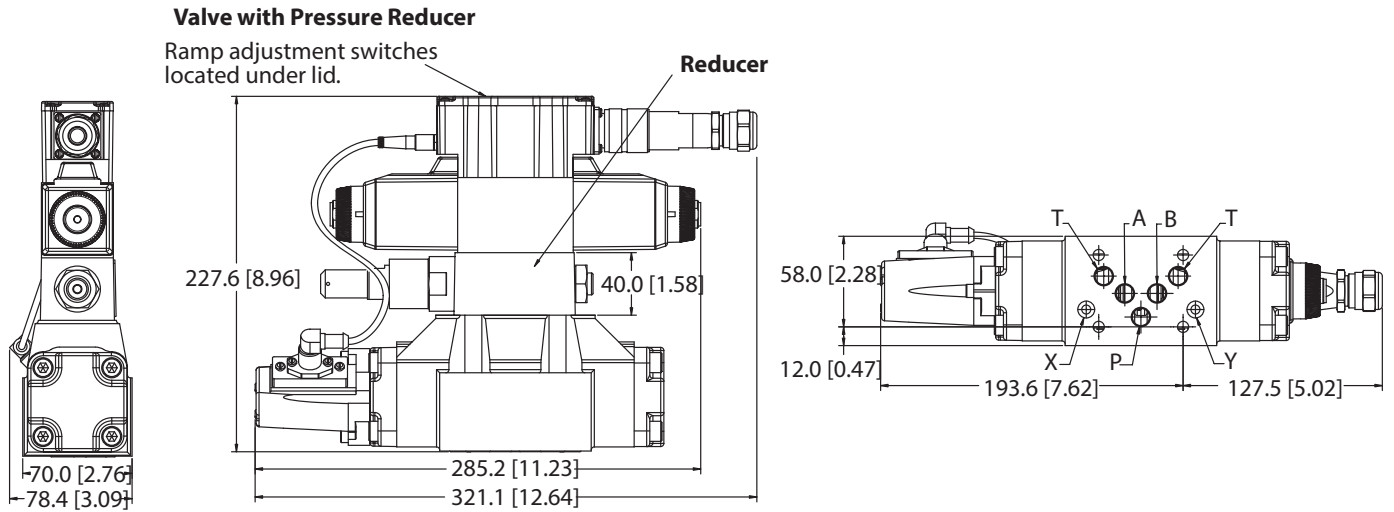

Mounting surface, seals supplied. For mating surface dimensions, see page 15 (size 05 with additional X and Y ports). For mounting subplate options and bolt options, see catalog Subplates and Connection Plates for Four-Port Directional Valves.

KBFDG5V-7

mm (Inch)

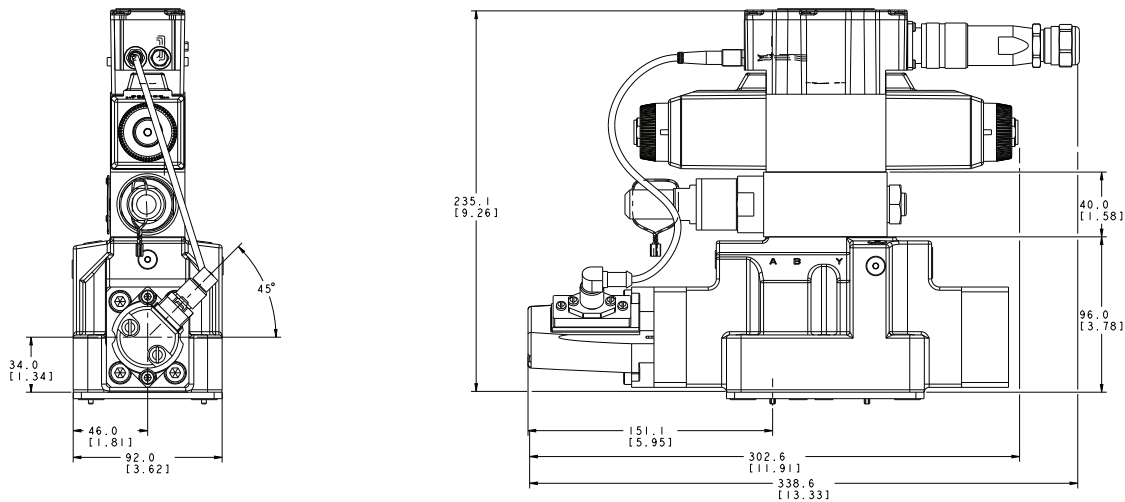

Mounting surface, seals supplied. For mating surface dimensions, see page 16. For mounting subplate options and bolt options, see catalog Subplates and Connection Plates for Four-Port Directional Valves.

Installation Dimensions

KBFDG5V-8, KBFDG5V-10

KBFDG5V-8

mm (Inch)

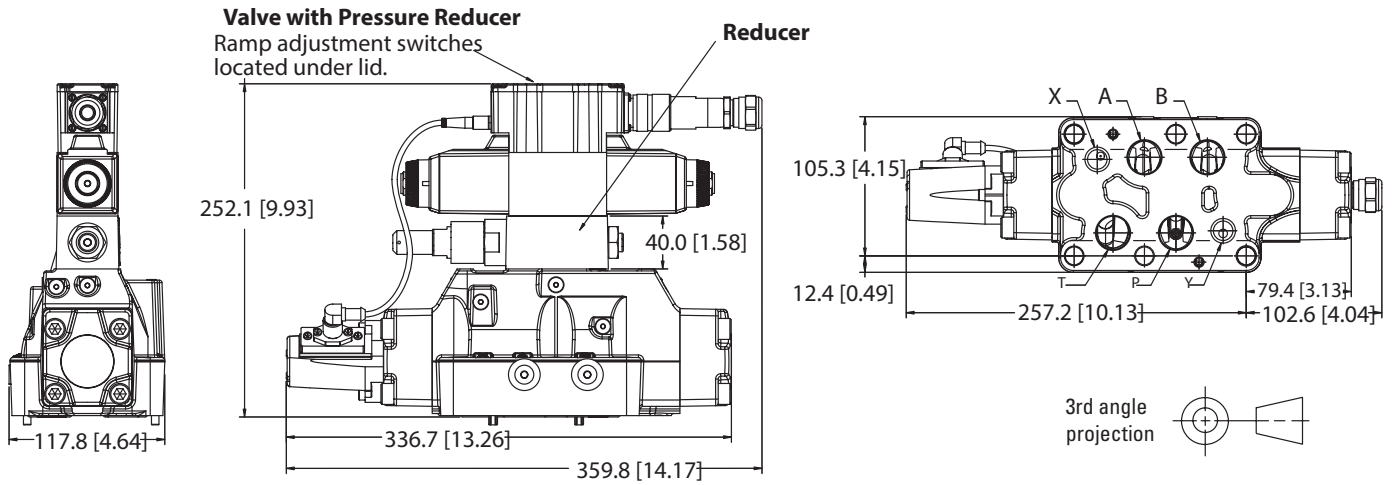

Mounting surface, seals supplied. For mating surface dimensions, see page 16. For mounting subplate options and bolt options, see catalog Subplates and Connection Plates for Four-Port Directional Valves.

KBFDG5V-10

mm (Inch)

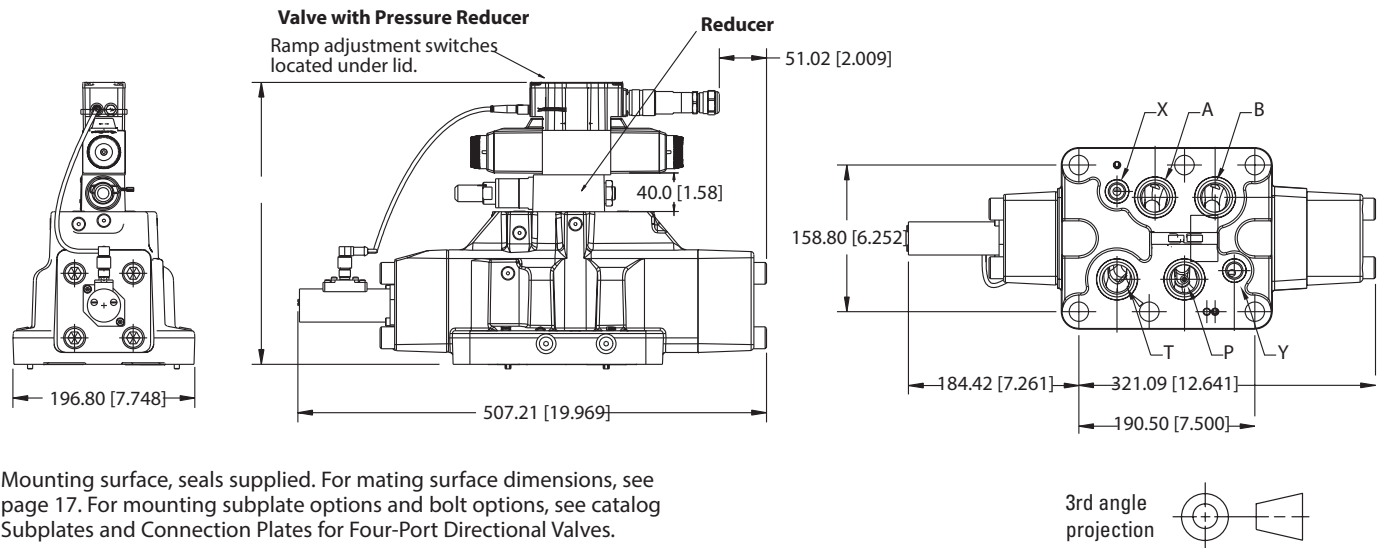

Mounting surface, seals supplied. For mating surface dimensions, see page 17. For mounting subplate options and bolt options, see catalog Subplates and Connection Plates for Four-Port Directional Valves.

Mounting Surfaces

KBFDG5V-8, KBFDG5V-10

Dimensions shown in mm (in).

General description

When a subplate is not used, a machined pad must be provided for valve mounting. Pad must be flat within 0,0127 mm (.0005 inch) and smooth within 1.6 mm (63 microinch). Mounting bolts, when provided by customer, should be ISO 898 class 12.9 or better. Bolt Kits See page 17.

Dimensional tolerances

Dimensional tolerance on interface drawings is 0,2 mm (0.008") except where otherwise stated. ISO 4401 specifies inch conversion to 0.01".

Conversion from metric

ISO 4401 gives dimensions in mm. Inch conversions are accurate to 0.01" unless otherwise stated.

Mounting bolt tappings

ISO 4401 gives metric thread tappings. Alternate UNC tappings are Vickers recommendations that allow these plates and associated valves to be used up to their maximum pressures, when using Vickers recommended bolt kits, or bolts of an equivalent strength. It is recommended that Customer's own manifold blocks for UNC bolts should be tapped to the minimum depths given in the footnotes.

ISO Standard size 05 without ports X and Y

This interface conforms to ISO 4401-05-04-0-05, NSI/B93.7M (and NFPA) size 05, CETOP R35H4 2-05, DIN 24340 from A10.

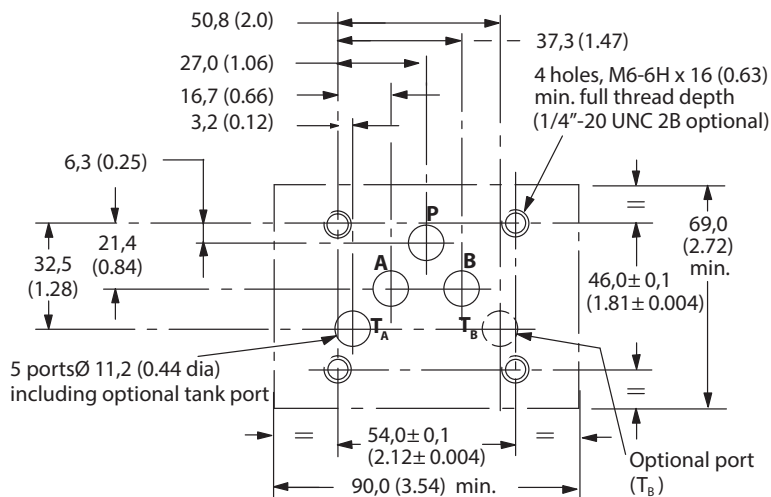

ISO Standard size 05 with ports X and Y

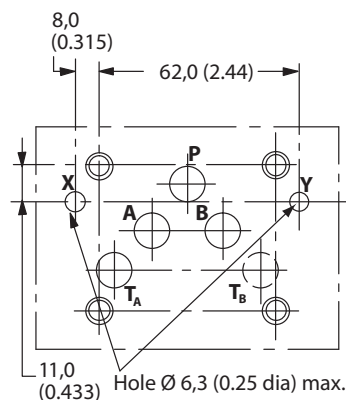

Mounting Surfaces

ISO Standard size 07 with ports X and Y

This interface conforms to: ISO 4401-07-07-0-05 ANSI/ B93.7M (and NFPA) size 07 CETOP R35H4.3-07, DIN 24340 Form A16.

Dimensions shown in mm (in).

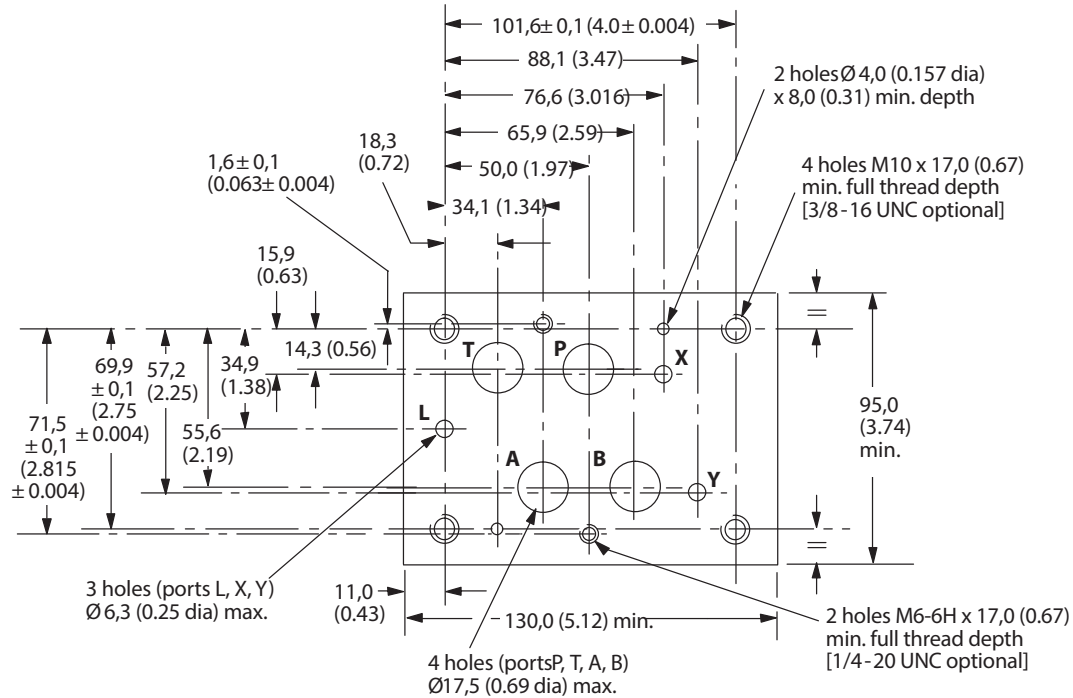

ISO Standard size 08 interface

This interface conforms to: ISO 4401-08-08-0-05 ANSI/B93.7M (and NFPA) size 08 CETOP R35H4.3-08, DIN 24340 Form A25.

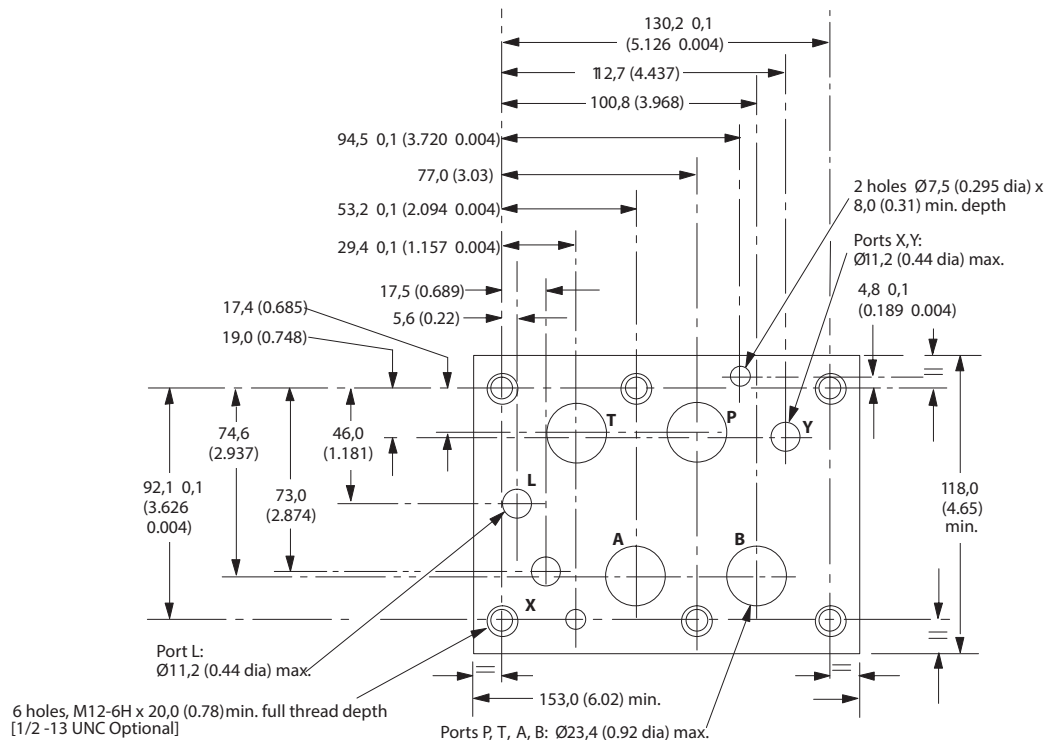

Mounting Surfaces

ISO Standard size 10 with ports X and Y

This interface conforms to: ISO 4401-10-09-0-05 ANSI/B93.7M (and NFPA) size 10, CETOP 35H4.3-10, DIN 24340 Form A32

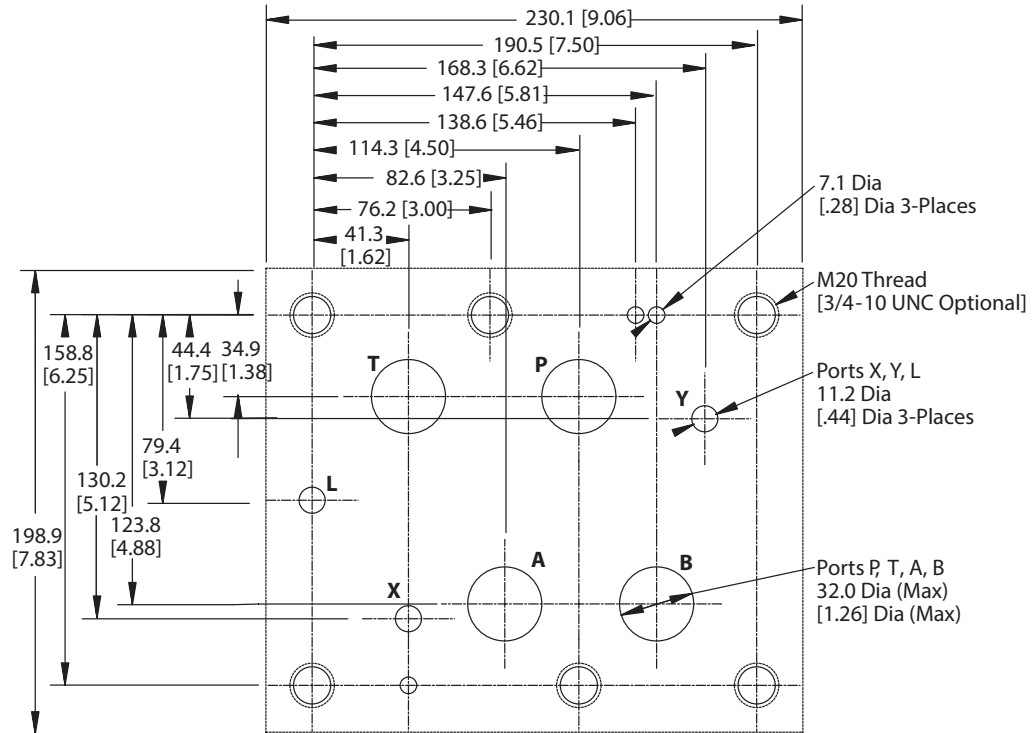

Electrical Information

Electrical block diagram

Voltage input (M1)

KBFDG5V-5/7/8/10

Wiring

Connections must be made via the 7-pin plug mounted on the amplifier. (As shown below). Please refer to Installation and Wiring practice for Vickers electronic parts and document pll_2079.

Command signals and outputs

7-pin plug		Flow direction
Pin D	Pin E	
Positive	OV	P to A
OV	Negative	
UD - UE = Positive		
Negative	OV	P to B
OV	Positive	
UD - UE = Negative		

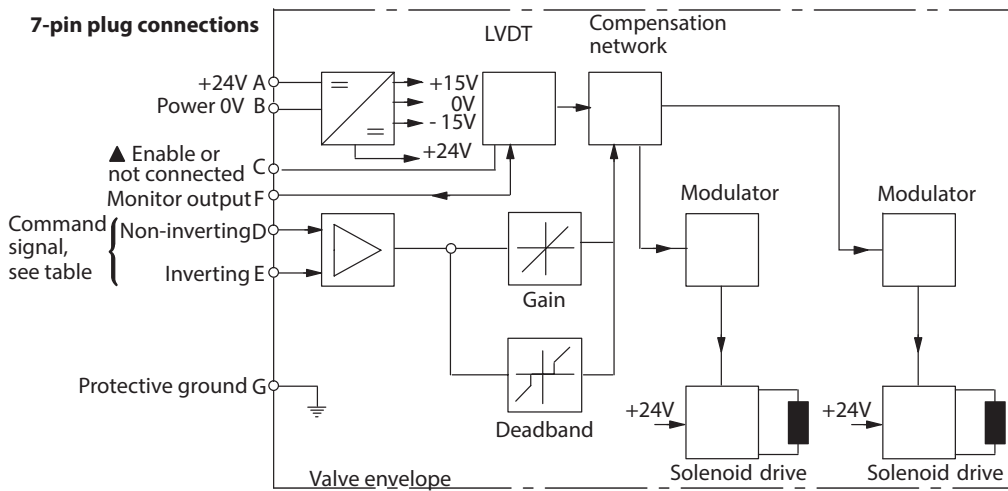

Note: ▲ In valves with PH7 or PR7 type electrical connection, pin C is used for a valve enable signal.

Command signals and outputs

7-pin plug

Current from Pin D to E	Pin E	Pin B	Flow direction
12-20mA	Current return	Power ground	P to A
4-12mA	Current return	Power ground	P to B



Warning

All power must be switched off before connecting or disconnecting any plugs.

Electrical Information

Voltage input (M1) wiring

■ Spool position monitor voltage (pin F) will be referenced to the KB valve local ground.

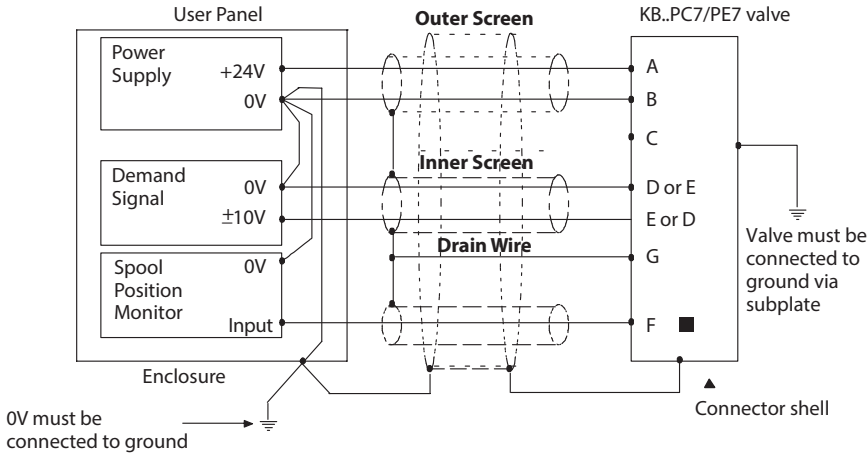

Wiring Connections for M1 Valves with “Enable” Feature

Note:

▲ In applications where the valve must conform to European RFI/EMC regulations, the outer screen (shield) must be connected to the outer shell of the 7 pin connector, and the valve body must be fastened to the earth ground. Proper earth grounding practices must be observed in this case, as any differences in command source and valve ground potentials will result in a screen (shield) ground loop.

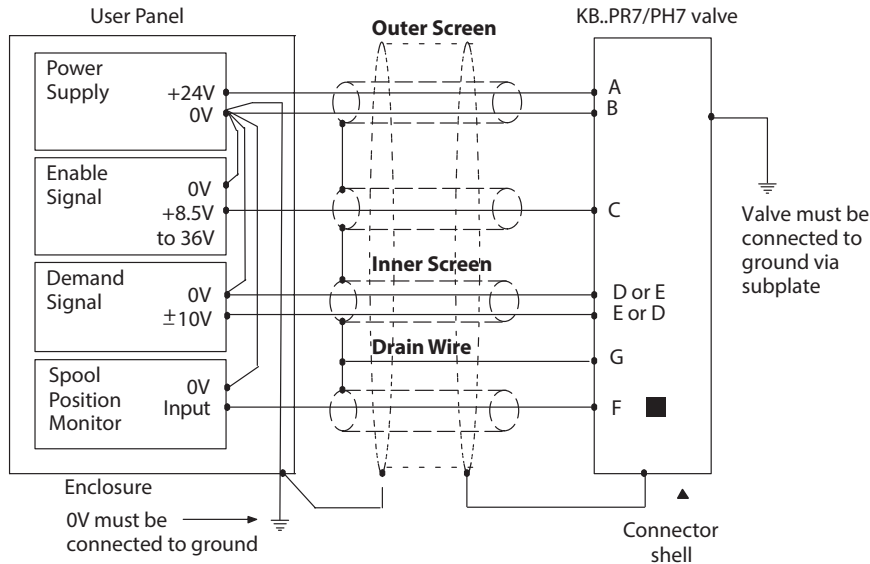

Electrical Information

Current input (M2) wiring

■ Spool position monitor voltage (pin F) will be referenced to the KB valve local ground.

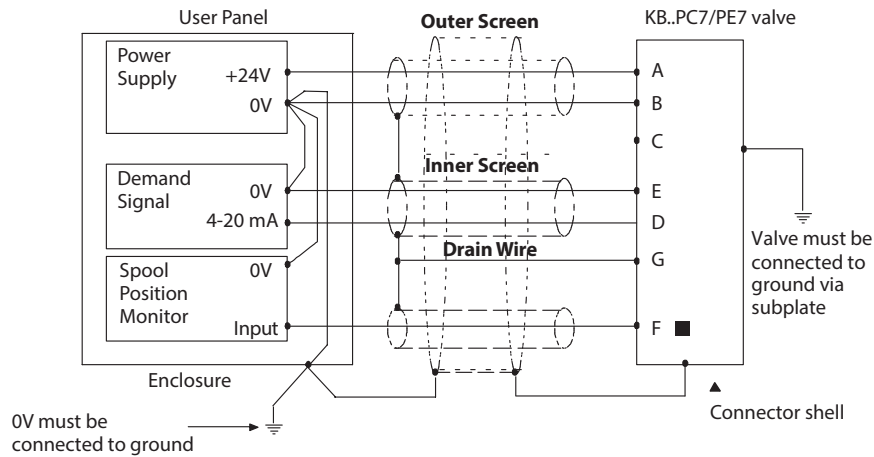

Warning

Electromagnetic Compatibility (EMC) It is necessary to ensure that the valve is wired up as above. For effective protection the user electrical cabinet, the valve subplate or manifold and the cable screens should be connected to efficient ground points. The metal 7 pin connector part no. 934939 should be used for the integral amplifier. In all cases both valve and cable should be kept as far away as possible from any sources of electromagnetic radiation such as cables carrying heavy current, relays and certain kinds of portable radio transmitters, etc. Difficult environments could mean that extra screening may be necessary to avoid the interference. It is important to connect the 0V lines as shown above. The multi-core cable should have at least two screens to separate the demand signal and monitor output from the power lines. The enable line to pin C should be outside the screen which contains the demand signal cables.

Wiring connections for M2 valves with enable feature

Note:

▲ In applications where the valve must conform to European RFI/EMC regulations, the outer screen (shield) must be connected to the outer shell of the 7 pin connector, and the valve body must be fastened to the earth ground. Proper earth grounding practices must be observed in this case, as any differences in command source and valve ground potentials will result in a screen (shield) ground loop.

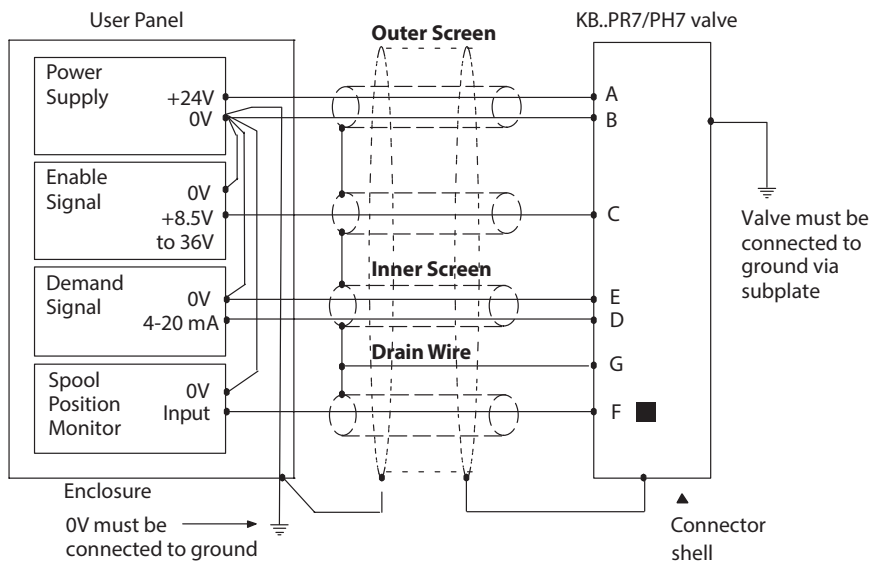

Application Data

Hydraulic fluids and fluid cleanliness

Recommendations on contamination control methods and the selection of products to control fluid condition are included in Vickers Hydraulic Fluid Recommendation 03-401-2010 rev 1.

For products in this catalog the recommended levels are:

0 to 70 bar (1000 psi) – 18/16/13

70 + bar (1000 + psi) – 17/15/12

Hydraulic fluids

Materials and seals used in these valves are compatible with antiwear hydraulic oils, and non-alkyl-based phosphate esters. The extreme operating viscosity range is 500 to 13cSt (2270 to 70 SUS) but the recommended running range is 54 to 13 cSt (245 to 70 SUS). For further technical information about fluids see “Technical Information” leaflet B-920 or I-286S.

Installation

The proportional valves in this catalog can be mounted in any attitude, but it may be necessary in certain demanding applications, to ensure that the solenoids are kept full of hydraulic fluid. Good installation practice dictates that the tank port and any drain port are piped so as to keep the valves full of fluid once the system start-up has been completed.

Mounting bolt kits

Pilot with reducer

metric	inch
BK464125M	BK870017

KBFDG5V-5 Mainstage

metric	inch
BKDG01633M	BKDG01633

KBFDG5V-7 Mainstage

metric	inch
BK464125M	BK870017

KBFDG5V-8 Mainstage

metric	inch
BKDG01633M	BKDG01633

KBFDG5V-10 Mainstage

metric	inch
BKDG10636M	BKDG10636

If not using Vickers recommended bolt kits, bolts used should be to ISO 898, 12.9 or better.

Seal kits

Pilot including M8 cap

5986617-001

Reducer

870739

KBFDG5V-5

Mainstage	Complete valve
565143	5986818-001

KBFDG5V-7

Mainstage	Complete valve
565144	5986819-001

KBFDG5V-8

Mainstage	Complete valve
5986821-001	5986820-001

KBFDG5V-8

Mainstage	Complete valve
02-441686	02-441691

Electrical connection

7-Pin connector

metal
934939

(metal connector must be used for full EMC protection).

▲ Note: An alternative metal connector which gives EMC protection but not IP67 rating is available from ITT-Cannon, part number CA06-COM-E-14S-A7-S.

Service information

The products from this range are preset at the factory for optimum performance; disassembling critical items would destroy these settings. It is therefore recommended that should any mechanical or electronic repair be necessary they should be returned to the nearest Vickers repair center. The products will be refurbished as necessary and retested to specification before return.

Field repair is restricted to the replacement of the seals..