

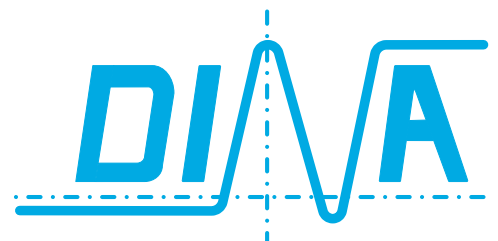

SLVARIO

Original Instruction Manual

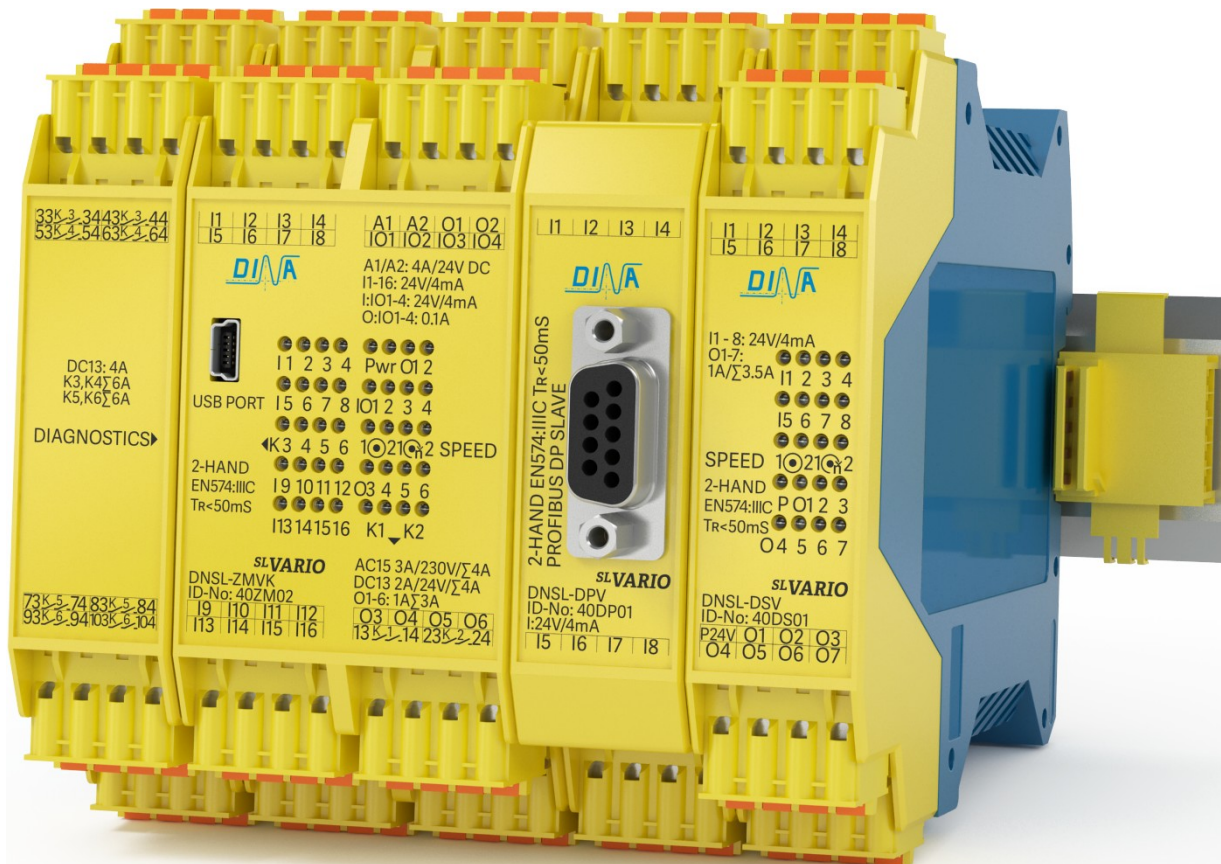



we are safety.

EU-Konformitätserklärung	EU declaration of conformity	
Déclaration UE de conformité	Dichiarazione di conformità UE	Declaración UE de conformidad

Die nachfolgend aufgeführten Produkte sind konform mit den Anforderungen der folgenden Richtlinien
The beneath listed products are in conformity with the requirements of the following directives
Les produits mentionnés ci-dessous sont conformes aux exigences imposées par les directives suivantes
I prodotti sotto elencati sono conformi alle direttive sotto riportate
Los productos listados a continuación son conforme a los requisitos de las siguientes directivas

Maschinenrichtlinie	2006/42/EG	EMV Richtlinie	2014/30/EU	RoHS-Richtlinie	2011/65/EU
Machinery directive	2006/42/EC	EMC Directive	2014/30/EU	RoHS Directive	2011/65/EU
Directive Machines	2006/42/CE	Directive de CEM	2014/30/UE	Directive de RoHS	2011/65/UE
Direttiva Macchine	2006/42/CE	Direttiva EMV	2014/30/UE	Direttiva RoHS	2011/65/UE
Directiva de máquinas	2006/42/CE	Directiva CEM	2014/30/UE	Directiva RoHS	2011/65/UE

Folgende Normen sind angewandt:	a	• EN 55011: 2009+A1: 2010 (class A)
Les normes suivantes sont appliquées:		• DIN EN 61326-1: 2013-07
Vengono applicate le seguenti norme:		• DIN EN 61326-3-1: 2015-06
Se utilizan los siguientes estándares:		• DIN EN 61000-6-2: 2016-05
 	b	• DIN EN 60947-5-1: 2015-05
	c	• DIN EN ISO 13849-1: 2016-06
	d	• DIN EN ISO 13849-2: 2013-02
	e	• DIN EN 574, Type IIIC: 2008-12
	f	• DIN EN ISO 13856-1:2013-08 / -2:2013-08 / -3:2013-12 Nur für Signalverarbeitung
		Dokumentenbeauftragter: Dirar Najib, Geschäftsführer
		Authorized person : Dirar Najib, General Manager

Zusatzanforderung: Supplementary requirements:	<ul style="list-style-type: none"> • DGUV Test: GS-ET-20: 2016-10 • DIN EN ISO 9001: 2015
---	---

<ul style="list-style-type: none"> • EG-Baumusterprüfbescheinigung: ET 17078 vom 01.09.2017 • DNSL-NIV und DNSL-SIV, Kategorie 3, PLd, nicht für Zwei-hand Funktion • Alle weiteren Module Kategorie 4, PLd Unter Anwendung der Tabelle 3 der DIN EN 13849-1: 2016-06 entspricht dies einem SIL 3. 	<ul style="list-style-type: none"> • EC-Type Test certificate: ET 17078 from 2017-09-01 • DNSL-NIV and DNSL-SIV, Category 3, PLd not for tow-hand function • All other modules Category 4 PLd Using table 3 of DIN EN 13849-1: 2016-6 this is conform to SIL 3
---	---

SL VARIO:			
Bezeichnung der Bauteile	DNSL-ZMV, DNSL-ZMVA DNSL-ZMVD, DNSL-ZMVK	Zentralmodule	Central modules
Description of components	DNSL-DSV, -DSV2, DSIV, -DRV, -SIV	Drehzahlüberwachungen	Speed monitoring
Description des composants	DNSL-INV, -IOV, -RMV	Ein- Ausgangsmodule	In- output modules
Descrizione dei componenti	DNSL-CMV	Kaskadenmodul	Cascade module
Descripción de componente	DNSL-NIV, DNSL-NRV	Netzwerk Module	Network modules
	DNSL-COV, -DPV, -ECV, -EPV, -MOV, -PLV, -PNV	Feldbusmodule	Field bus modules

Notifizierte Stelle		DGUV TEST, Prüf- und Zertifizierungsstelle, Elektrotechnik
Notified body	Organismo notificato	Fachbereich: ETEM
Organismo notificado	Organisme notifié	Gustav-Heinemann-Ufer 130/ 50968 Köln/ Germany
		Kenn-Nummer: 0340

Dokumentenbeauftragter	Authorized person	Dirar Najib, Geschäftsführer / CEO
		Esslinger Str. 84/ 72649 Wolfschlugen/ Germany

Wolfschlugen, 22. Oktober 2018

Dirar Najib

SLVARIO

The direct way to safe automation

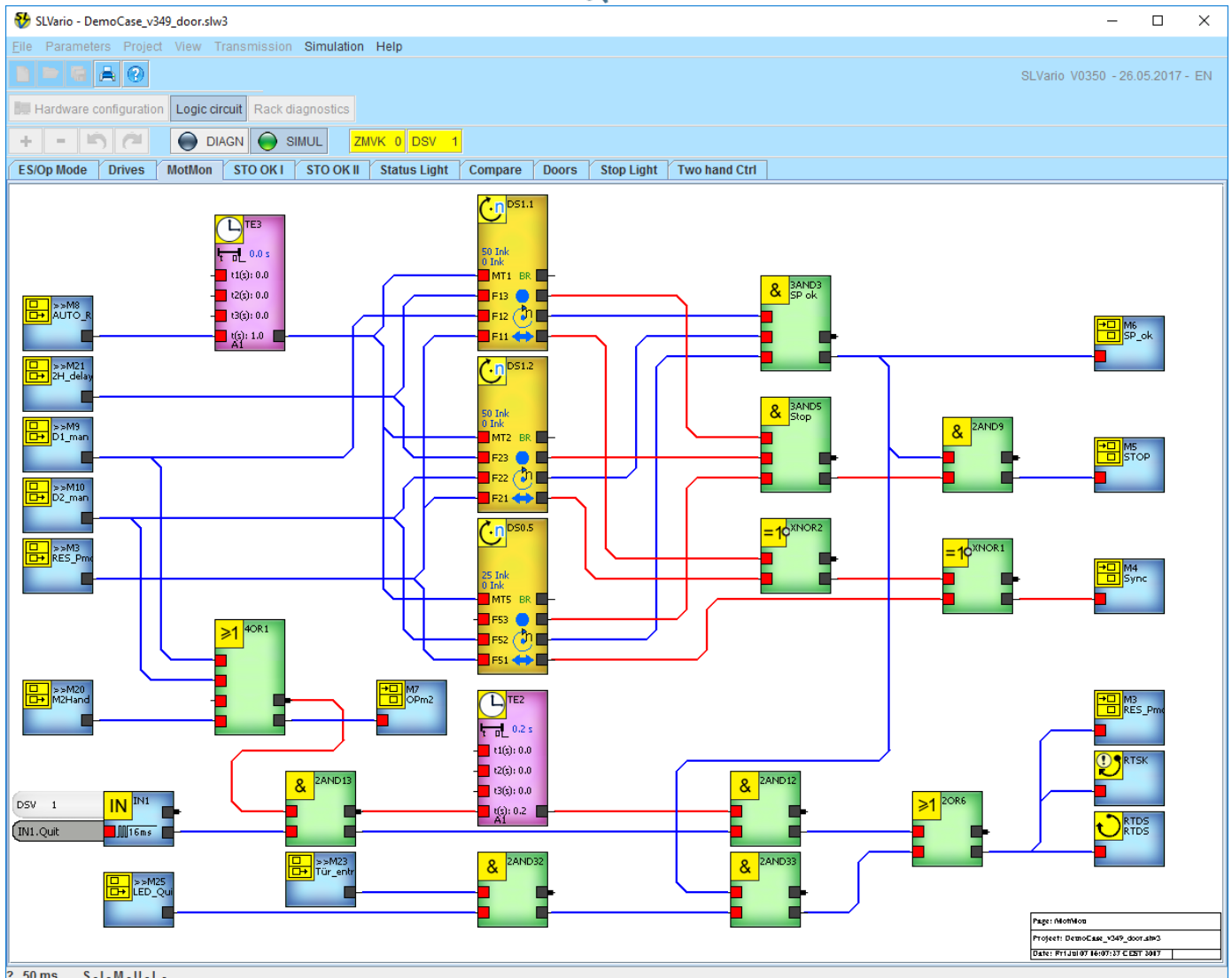
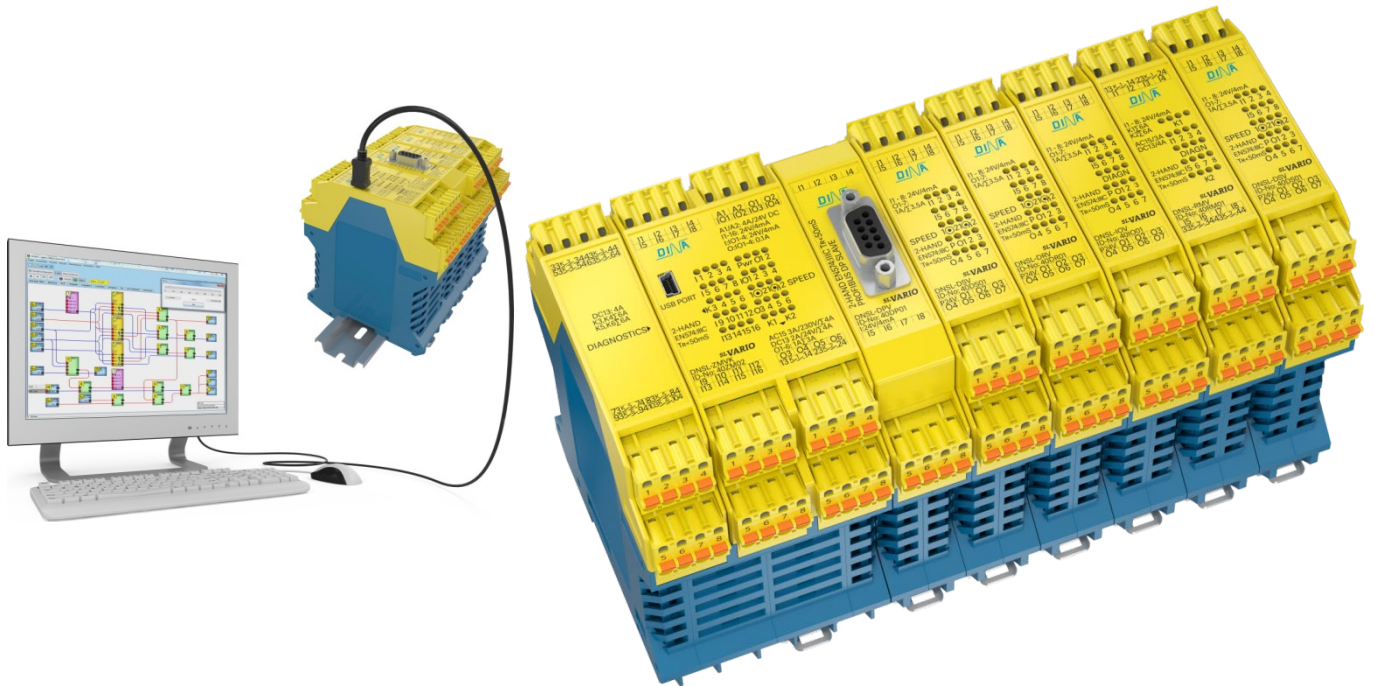

Contents

1	SL VARIO Modules.....	8
2	Intended purpose	8
2.1	Certification data.....	8
3	Safety regulation.....	9
3.1	Important notes and validation	9
4	Product description	10
4.1	Usage example:	10
4.2	Mounting.....	11
4.3	Terminal.....	11
5	Central modules.....	12
5.1	Connection schematic	12
5.2	Central module DNSL-ZMVA.....	13
5.3	Front side.....	14
5.4	Switching status display	14
6	Standstill and speed monitoring.....	15
6.1	Connection schematic	15
6.2	Front side.....	16
6.3	Switching status display	16
7	In-, output modules.....	17
7.1	Connection schematic	17
7.2	Front side.....	18
7.3	Switching status display	18
8	Field bus modules.....	19
8.1	Usage	19
8.2	Connection schematic	19
8.3	Front side.....	20
8.4	Switching status display	20
9	Cascade module DNSL-CMV.....	21
9.1	Usage	21
9.2	Serial and star shape cascade.....	21
9.3	Addressing of the function modules.....	22
9.4	Front and side view	22
9.5	Switching status display	22
10	Network module DNSL-NIV	23
10.1	Usage of DNSL-NIV	23
10.2	Connection schematic	23
10.3	Networking of SL VARIO applications.....	23
10.4	Front and side view	24
10.5	Switching status display	24
11	Network module DNSL-NRV	25
11.1	Usage of DNSL-NRV.....	25
11.2	Connection schematic	25

Contents

11.3	RJ45 Female connection schematic, front and side view	26
12	Diagnostics module DNSL-DMV	27
12.1	DNSL-DMV usage	27
12.2	DNSL-DMV display	27
12.3	Analogue inputs at the central module	28
12.4	Inputs for function mode selection switch (FMSS) at central module	28
12.5	Inputs for Tow-Hand function according EN 574: Type IIIC	28
12.6	Inputs for shut down mats, switch rails and bumpers at central module	29
12.7	Important notes with using of shutdown mats, switch rails and bumpers	29
12.8	Inputs for Safety circuits (SC) with manual Quit	30
12.9	Inputs for Safety circuits (SC) with Quit via Q	31
12.10	Quit of safety circuit (SC)	31
12.11	Inputs for Safety circuits (SC) without Quit	32
13	Data in- and outputs at the field bus	32
14	Inputs for standstill and speed monitoring	33
14.1	Inputs for standstill and speed monitoring at the central module	33
14.2	Requirements for the sensors for safe monitoring	33
14.3	Inputs for standstill and speed monitoring at the central module DNSL-ZMVD34	33
14.4	Input for safe standstill and speed monitoring at DNSL-DSV and DSV2	35
14.5	Requirements of the incremental measuring system	35
14.6	Two sensors measuring system with DNSL-DSV	35
14.7	Ramp monitoring with DNSL-DSV and DSV2	35
14.8	Inputs for standstill and speed monitoring at DNSL-DSIV	36
14.9	Input for standstill and speed monitoring at DNSL-DRV	36
14.10	Inputs for standstill and speed monitoring at DNSL-SIV	37
14.11	Direction monitoring with DSV, DSV2, DSIV, DRV und SIV	37
14.12	Quit of speed monitoring	37
14.13	DNCO function to monitor the Peripheral speed	37
14.14	Selection of DNCO-Multiplexer	38
15	Cable adapter DNDA	38
16	Outputs at SL VARIO	39
17	General technical data	40
17.1	Electrical characteristics	40
17.2	Environment conditions	40
17.3	Technical data of the Semiconductor outputs	40
	Technical data Semiconductor outputs	40
17.4	Technical data of the contact outputs	41
17.5	Electrical life of the contact outputs	41
18	Dimensions	42
18.1	Fitting and remove	42

1 SL VARO Modules

Central modules	Speed monitoring	In-, output modules	Network module	Field busses	Cascade module
DNSL-ZMV DNSL-ZMVA DNSL-ZMVD DNSL-ZMVK	DNSL-DSV DNSL-DSV2 DNSL-DSIV DNSL-DRV DNSL-SIV	DNSL-INV DNSL-IOV DNSL-RMV	DNSL-NIV DNSL-NRV	DNSL-COV DNSL-DPV DNSL-ECV DNSL-EPV DNSL-MOV DNSL-PLV DNSL-PNV	DNSL-CMV





2 Intended purpose

Testing based on:

- EN 55011: 2009+A1 2010 (class A), DIN EN 61326-1: 2013-07, EN 61000-6-2: 2016-05, EN 61326-3-1: 2015-06, EN 61000-4-11: 2005-02
- DIN EN 60947-5-1: 2015-05
Low-voltage switch gear, part 5.1: Control circuit devices and switching elements-electromechanical control circuit devices
- DIN EN ISO 13849-1: 2016-06
Safety-related parts of control systems; Part 1: General principles for design category 4, PL_e
Using table 3 of DIN EN 13849-1: 2016-06 this is conform to SIL 3
- DIN EN ISO 13849-2: 2013-02
Safety-related parts of control systems; Part 2: Validation
- DIN EN 574, type IIIC: two-hand control devices
- DIN EN ISO 13856-1:2013-08 / -2:2013-08 / -3:2013-12, for signal processing only
- GS-ET-20: 2016-10:
basic principles for testing and certification of safety switch devices

Authorized person for the combination of the technical documents: Dirar Najib, CEO
Esslinger Str. 84, D 72649 Wolfschlügen,
Wolfschlügen, 2017-07-27

2.1 Certification data

Modul	MTTFd	PL	DC	SFF	PFHd	 ET 17079 Sicherheit geprüft tested safety  T _M :20 years	 US LISTED IND.CONT.EQ 1ZD7 E227037 
DNSL-ZMV	79 years	E	high	99%	3.0 x 10 ⁻⁸		
DNSL-ZMVK	141 years	E	high	99%	1.6 x 10 ⁻⁸		
DNSL-DSV	97 J years	E	high	96%	2.5 x 10 ⁻⁸		
DNSL-DRV	97 years	E	high	96%	2.5 x 10 ⁻⁸		
DNSL-SIV	165 years	D	high	95%	3.3 x 10 ⁻⁸		
DNSL-INV	238 years	E	high	95%	1.4 x 10 ⁻⁸		
DNSL-IOV	97 years	E	high	96%	2.5 x 10 ⁻⁸		
DNSL-RMV	91 years	E	high	98%	2.5 x 10 ⁻⁸		
DNSL-CMV	91 years	E	high	98%	2.5 x 10 ⁻⁸		
DNSL-NIV	214 years	D	high	95%	1.1 x 10 ⁻⁸		
DNSL-DPV	305 years	E	high	95%	8.0 x 10 ⁻⁹		
DNSL-ECV	305 years	E	high	95%	8.0 x 10 ⁻⁹		
DNSL-COV	305 years	E	high	95%	8.0 x 10 ⁻⁹		

Product is evaluated as safety device according to: DIN EN ISO 13849-1: 2008-12, category 4, PL_e

- Certificated by: (Fachausschuss für Elektrotechnik, Prüf- und Zertifizierungsstelle Köln), European notified institution, Identification-number 0340 EC-Type Test certificate (DGUV Test: ET 17078 from 2017-09-01)
- EMC-directive certificated by "ELMAC GmbH Bondorf", Reg. No.: DAT-P-206/05-00
- CNL, USL: File E227037
- QM System certificated according to DIN EN ISO 9001:2015 by "DQS, Frankfurt", Reg.-No.: 067542 QM 08
- Certificate and declaration of conformity: See www.dina.de, download

3 Safety regulation

- The device may only be installed and commissioned by an electrician or trained persons who are familiar with these operating instructions and the applicable regulations regarding work safety and accident prevention.
- Observe the VDE, EN and local regulations, particularly with respect to the protective measures.
- Failure to observe the regulations may result in death, severe bodily injury or extensive property damage.
- For emergency-stop applications, either the integrated function for restart interlock must be used or automatic restarting of the machine must be prevented by means of a higher-level control.
- During transport, storage and operation adhere to the conditions specified in EN 60068-2-1, 2-2!
- Unauthorized modifications shall render any warranty null and void. Dangers may thereby arise that could result in severe injuries or even death.
- Install the device in a control cabinet with a protection class of at least IP54! Dust and moisture may otherwise result in impaired functions.
Installation in a control cabinet is mandatory.
- Ensure adequate protection circuits at output contacts for capacitive and inductive loads!
- The device is to be installed taking into account the distances required per DIN EN 50274, VDE 0660-514.
- During operation, switching devices carry dangerous voltage. Do not remove protective covers.
- Replace the device after the first malfunction!



- Properly dispose of the device at the end of its service life. 
- If these regulations are not adhered to or in the event of improper use, DINA Elektronik GmbH accepts absolutely no liability for the resulting property damages or personal injury.
- Save this product information!

3.1 Important notes and validation

- The product described here was developed to perform safety-related functions as part of a complete system.
- The complete system consists of sensors, evaluation and message units as well as concepts for safe shutdowns.
- It is the responsibility of the manufacturer of a system or machine to ensure the proper overall function.
- The manufacturer of the system is required to test and to document the effectiveness of the implemented safety concept within the complete system.
- This verification is to be performed after every modification to the safety concept or to safety parameters.
- DINA Elektronik is not in the position to guarantee the properties of a complete system that was not designed by DINA.
- DINA Elektronik GmbH also accepts no liability for recommendations that are given or implied by the following description.
- No new guarantee, warranty or liability claims that extend beyond DINA's general delivery conditions can be derived on the basis of the following description.
- To avoid EMC disturbances, the physical environmental and operating conditions at the installation location of the product must comply with section EMC of DIN EN 60204-1.
- The safety function must be required every month if there is performance level (e) and every year if there is performance level PLd is required by using contact outputs.
- The information in the general technical data at the end of the operating instructions must be adhered to.

4 Product description

- SL VARIO is a multi-functional, modular and configurable safety system.
- The system consists of a central module and different function- and field bus modules.
- The field bus enables a communication between SL VARIO and the field bus master.
- The product is appropriated to be used in machines and automation to avoid dangers.
- The central module is available in 45 or 67.5 mm housing depending on the quantity of outputs. All other modules are in 22.5 mm housing.
- Mounting happens on a 35 mm standard rail.
- The modules are connected directly to the ground via the standard rail.
- The modules are plugged together via a bus connector at the rail side. The bus is on 2 channels.
- Up to 15 modules can be used in one application.
- Modules with different functions are available.
- A variety of functions are available such as speed monitoring, logic modules, timers, safety circuits, mode selector, generator, counters, comparators, feedback, restart interlock functions.
- A lot of safe digital and analogue inputs, safe semiconductor and contact outputs are available.
- The status of inputs, outputs, power supply and diagnostic functions is displayed via LED.
- Online and rack diagnostic are available via the Designer.
- An application can be simulated without hardware.
- Overvoltage and overcurrent are monitored.
Voltage $\geq 30V$ or not connected terminal (A2) disconnects internally the terminals (A1) and (P).
- Semiconductor outputs are overload and short-circuit-proof.
- An internal temperature sensor for diagnostic function via the Designer is available in all modules.
- The user's application will be developed through the Designer. The data transfer happens via the USB interface at the central module.
- The Designer is software developed by DINA.
- A memory chip is installed inside the central module. Documents as application software, Designer and instruction manuals can be transferred to the memory using the USB interface.
- The memory chip can be used as a drive.

Remark

The function devices are tested safe and certificated as a part of the firmware.

A modification of the certified function devices as part of the firmware is excluded.

4.1 Usage example:

Metal machining

Wood machining

Filling machines

Packing machines

Moving stairs

Lifts

Theatre stage technic

Driverless transport systems and much more

4.2 Mounting

- The central module is placed on the left side. All other modules must be added to the right side.
- For an application a central module is necessary.
- The number of the functional modules depends on the requirements.
- The plugs for measurement systems at the speed monitoring and for the data interface at the network and cascade module are on the top side of the module after mounting.
- RJ45 plugs are also at the bottom side of DNSL-ZMD and DNSL-NRV for speed monitoring and network. They are to use for description function only.
- The connecting cable can be fed directly into the cable channel.
- The field bus connector is at the front side.

Central module	Speed monitoring			In-, output modules				EtherCAT
DNSL-ZMVK	DNSL-DSIV	DNSL-DRV	DNSL-INV	DNSL-IOV	DNSL-RMV	Bus		DNSL-ECV

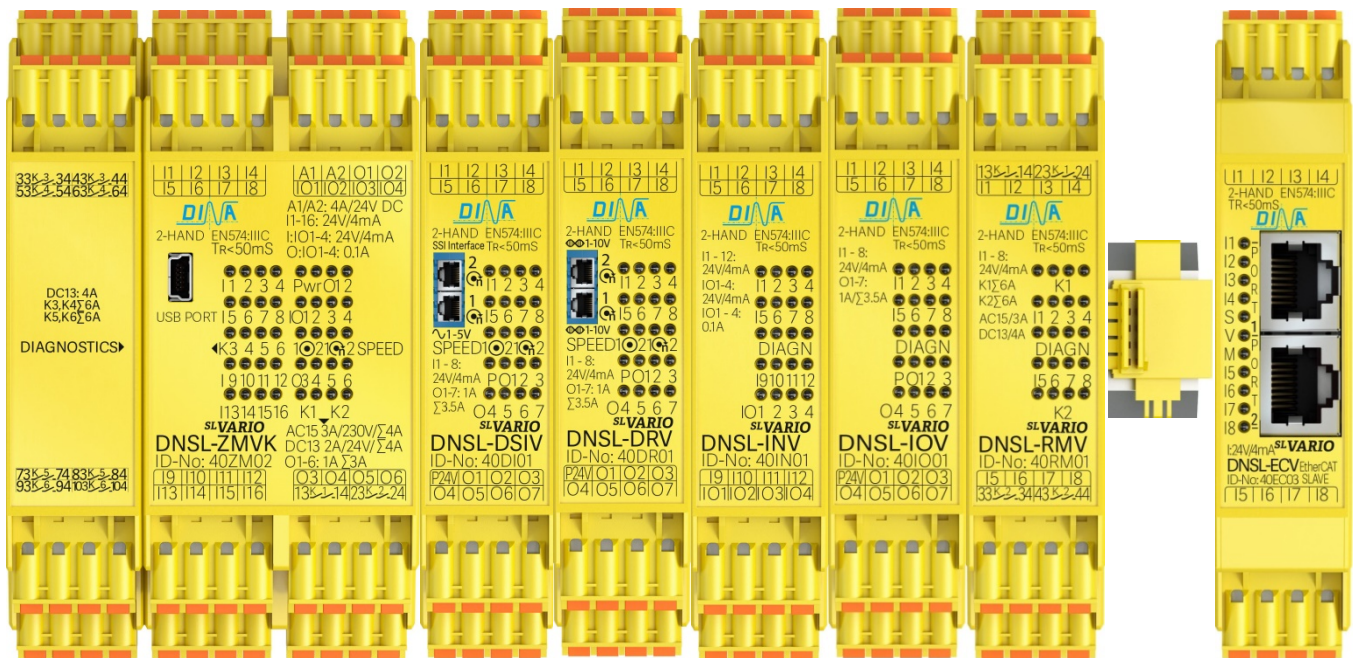

4.3 Terminal

Single terminal	Twin terminal
In standard the modules are equipped with single terminals. Unlocking happen above the terminals	All modules are deliverable with twin terminals. Unlocking: above or between the terminals

5 Central modules

	Terminal				Connector	Description		
	Single	Twin	Single	Twin				
DNSL-ZMV	ID-No.: 40ZM01 40ZM31*	ID-No.: 40ZM21 40ZM32*	ID-No.: 42ZM01 42ZM06*	ID-No.: 42ZM51 42ZM56*	I1-I8	Safe analogue-digital inputs for safety functions		
ZMVK	40ZM02 40ZM04	40ZM22 40ZM24	42ZM02 42ZM04	42ZM52 42ZM54				
ZMVA	46ZM01	46ZM51						
ZMVD	44ZM01	44ZM51	48ZM01	48ZM51				
ZMV	40ZM05	40ZM25	42ZM05	42ZM55			I1-I8	Safe analogue inputs only
all							I9-I16	Safe digital inputs for safety functions
all					1: I9/I10 2: I11/I12	2 safe monitoring of standstill and speed via sensor with 24V signals		
ZMV	40ZM03	40ZM23	42ZM03	42ZM53	1: I9-I12 2: I13-I16	2 safe monitoring of standstill, speed, position, direction and brake HTL measuring system		
ZMVK	40ZM04	40ZM24	42ZM04	42ZM54				
ZMVD	44ZM01	44ZM51	48ZM01	48ZM51	I17-I32	Safe digital inputs		
ZMVD	48ZM01	48ZM51			I33-I48	Safe digital inputs		
ZMVD	44ZM01 48ZM01	44ZM51 48ZM51				4 safe speed monitoring (44ZM51) 8 safe speed monitoring (48ZM51) of standstill, speed, position, direction and brake, sin/cos or TTL measuring system		
all					IO1-IO4	Safe digital inputs or Safe semi-conductor outputs		
all					O1-O6	Safe semi-conductor outputs		
all					K1-K2	Safe contact outputs		
ZMVK	40ZM02 40ZM04	40ZM22 40ZM24	42ZM02 42ZM04	42ZM52 42ZM54	K3-K6	Safe contact outputs each 2 contacts		
all						USB interface for data transfer with data memory*		
all					A1/ A2	Betriebsspannung 24V DC für das Zentralmodul und alle weiteren Module in der Applikation.		

*40ZM31, 40ZM32, 42ZM06 and 42ZM56: No contact outputs K1, K2 and no data memory

5.1 Connection schematic

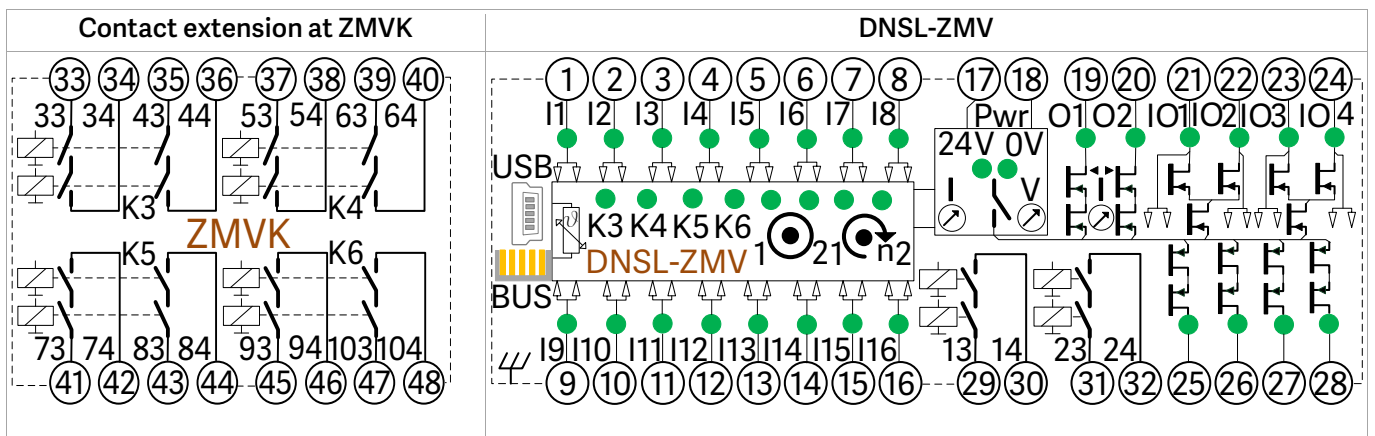

	RJ45 female for measuring system connection via DINA cable adapter Typ DNDA xx		Standstill display		Speed display		Connector to earth via DIN rail
			Switching status display for K3-K6				

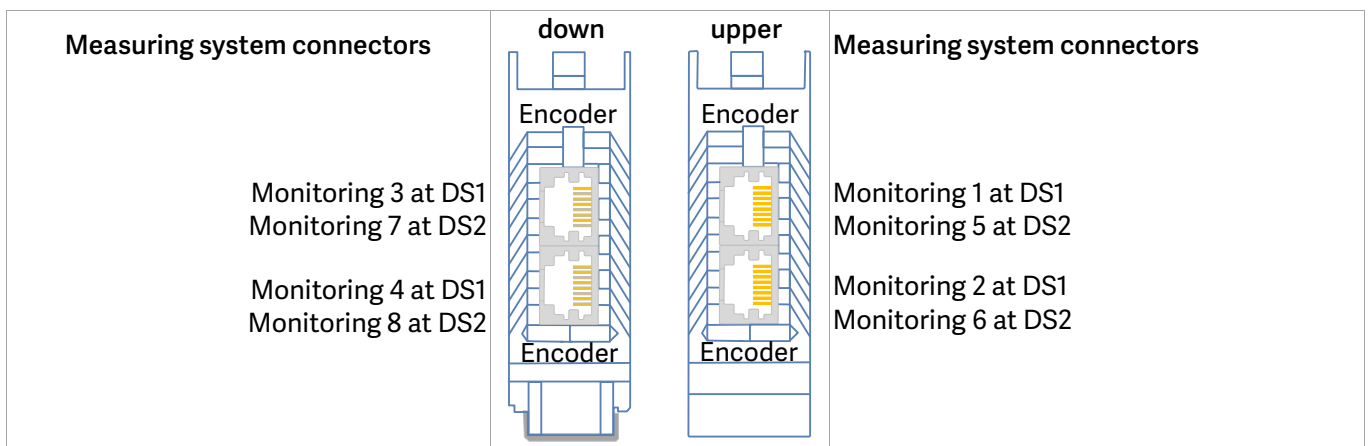
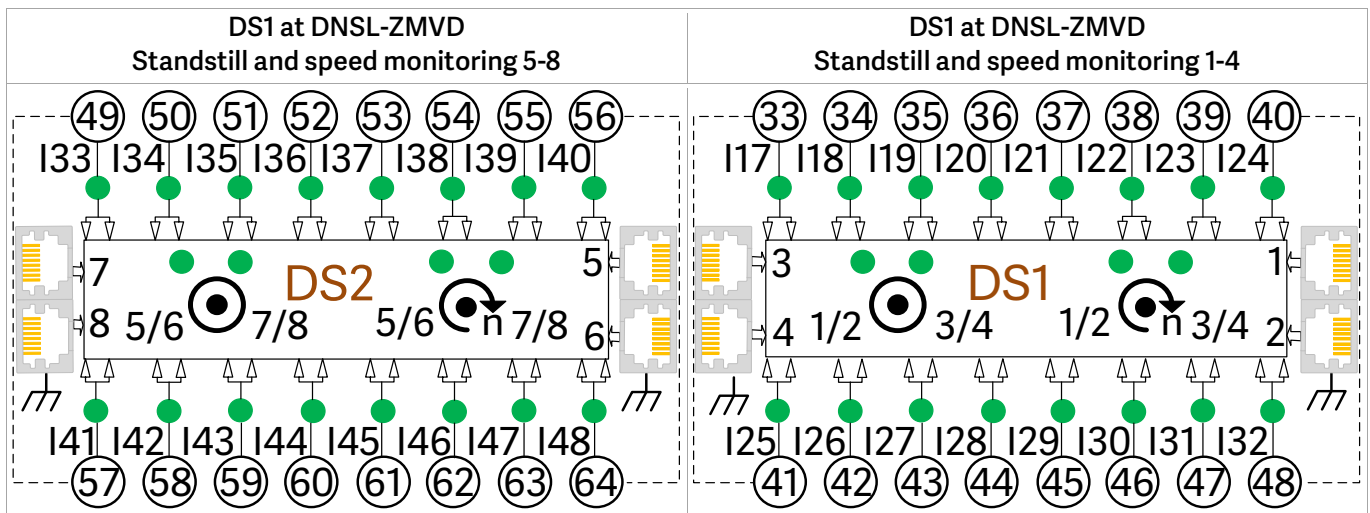

5.2 Central module DNSL-ZMVA

Analogue part of DNSL-ZMVA
Basis part: see DNSL-ZMV

I: 4-20mA
U: 0-10V

Description of the analogue part:

The outputs AO1 to AO4: 4-20mA.
The outputs AO5 to AO8: 0 bis 10V
Current and voltage outputs are proportional to gather.

AO1 (4 to 20mA) to AO5 (0...10V)
AO2 (4 to 20mA) to AO6 (0...10V)
AO3 (4 to 20mA) to AO7 (0...10V)
AO4 (4 to 20mA) to AO8 (0...10V)

- The source to control the analogue outputs can be configured using the parameter mask at the Designer.
- Sources are analogue terminals, standardized values (weight power), adders, subtractors etc.
- A minimum and a maximum has to be entered in the Designer mask.
- For more details, see the instruction manual Designer.

5.3 Front side

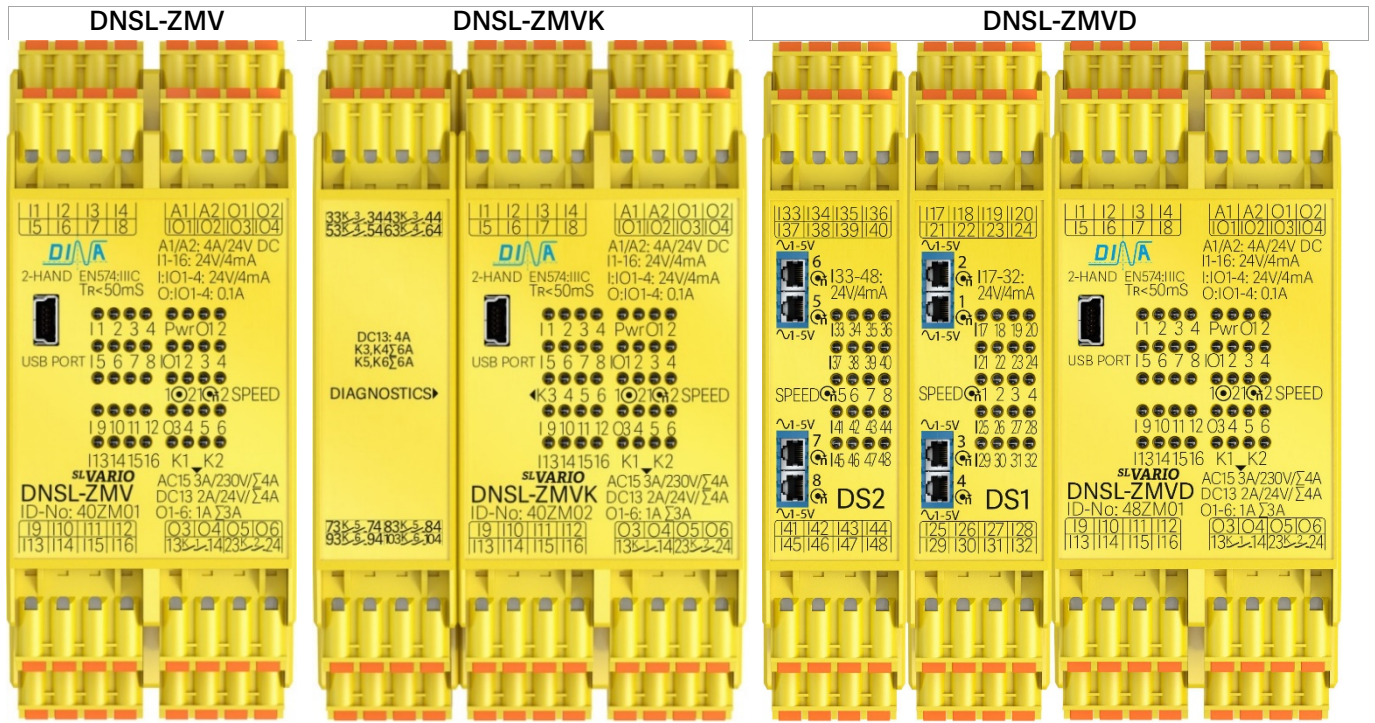

5.4 Switching status display

In- Outputs			Pwr: 1 2	
I1 — I48	Signal = 0V	Signal = 24V	Pwr 1 : Data transfer	
IO1 – IO4	Signal = 0V	Signal = 24V	Pwr 1 : Error	
O1 – O6	= 0	> 0 ≤ max.	Pwr 1 : OK not Valid	
IO1 – IO4	= 0	> 0 ≤ max.	Pwr 1 : Valid	
K1 / K2			Pwr 2 : Synchronisation	
K3 – K6			Pwr 2 : Error	
			Pwr 2 : OK	

Standstill and speed monitoring at ZMV, ZMVK and ZMVD



DNSL-ZMVD/ DS1 (LED 1 – 4)/ DS2 (LED 5 – 8)

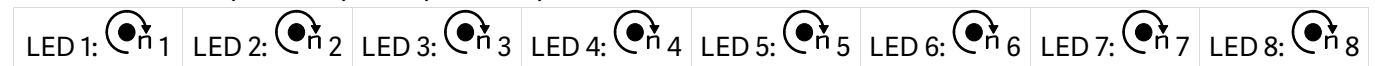

Switching status display of the standstill and speed monitoring at DNSL-ZMVD/ DS1 and DS2

LED 1- 8: monitoring 1- 8	Standstill output	Speed output	Standstill output
n = 0			Configurable using Designer
n > 0 < max.	-s		
n > max.			n = 0
n > max.			
no encoder			
n = Speed	n: monitoring		

Central modules

Standstill and speed monitoring

	Terminal		Connector	Description
	Single	Twin		
DNSL-	ID-No.:	ID-No.:	Connector	Description
DSV	40DS01	40DS21	11-18	Safe digital inputs for safety functions
DSIV	40DI01	40DI21		
DRV	40DR01	40DR21		
SIV	40SI01	40SI21		
	alle	alle		2 Safe monitoring of standstill, speed, position, direction and brake in different operating modes
DSV	40DS01	40DS21		Sin/Cos, TTL, HTL Measuring system,
DSV	40DS02	40DS22		HTL A and B track only
DRV	40DR01	40DR21		Resolver Measuring system
SIV	40SI01	40SI21		SSI Interface
DSIV	40DI01	40DI21		Sin/Cos, SSI interface with comparator function
DSV DRV	alle	alle	O1, O2	Semi-conductor outputs also clock outputs
DSV DRV	alle	alle	O3-O7	Safe semi-conductor outputs
DSV DSIV	40DS51 40DI01	40DS71 40DI21	O1-O7	Safe semi-conductor outputs
SIV	40SI01	40SI21	O1-O4	Safe semi-conductor outputs
	alle	alle	P	24V DC to supply the semi-conductor outputs Monitored voltage

5.5 Connection schematic

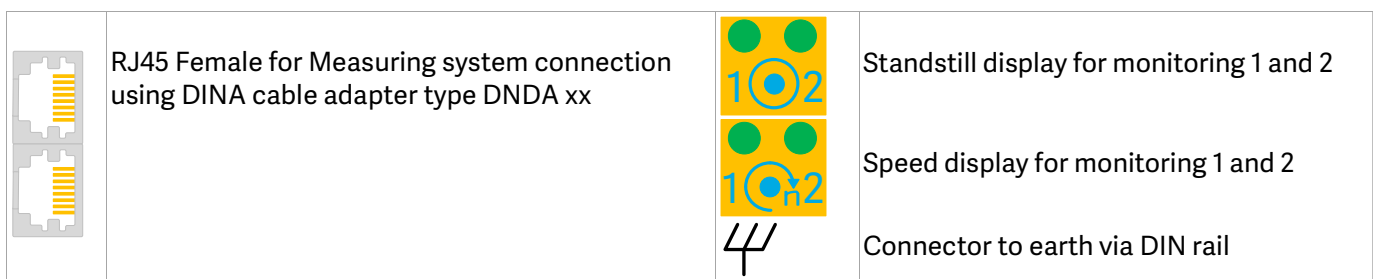
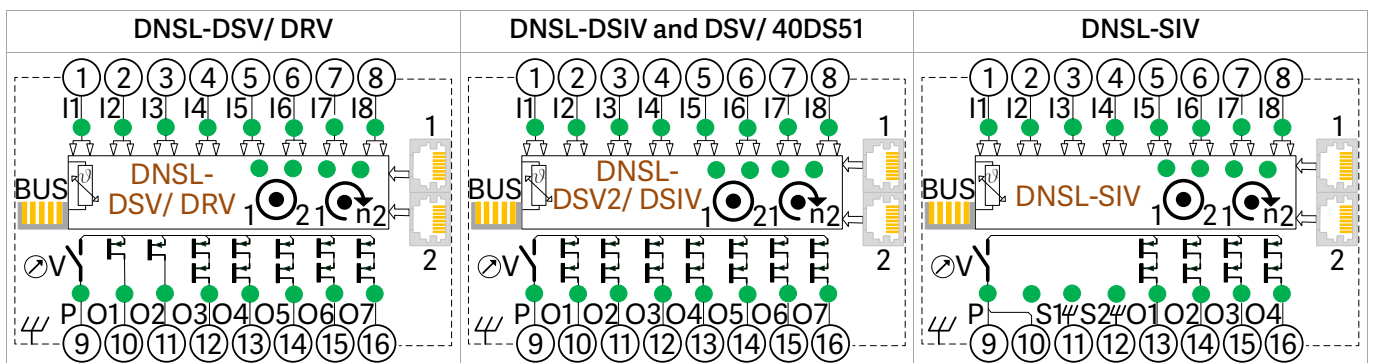

5.6 Front side

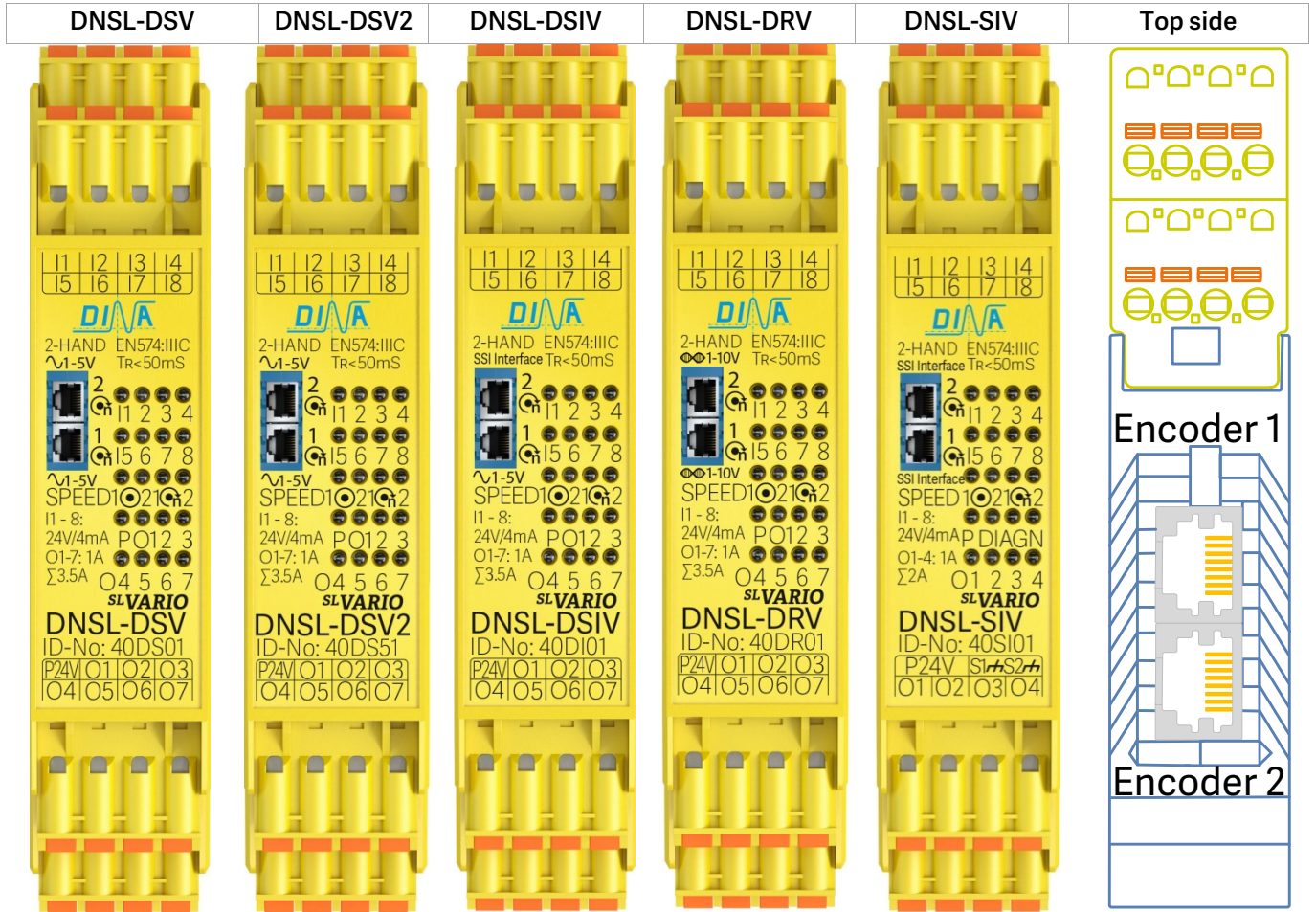

5.7 Switching status display

I1 – I8	Signal = 0V	Signal = 24V
P	Pwr = 0V	Pwr = 24V
1 2 1 2	$n = 0$ at 1 + 2	1 2 $n > 0$ at 1+2
1 n 2 1 n 2	$n < \text{max.}$ at 1 + 2	1 n 2 $n > \text{max.}$ at 1+2
1 n		
n 2		
O1 – O7	I = 0	I > 0 ≤ max.
O1 – O4	I = 0	I > 0 ≤ max.
n = Speed	DSV / DRV O1, O2	O3 – O7

6 In-, output modules

	Terminal		Connector	Description
	Single	Twin		
DNSL-	ID-No.:	ID-No.:		
INV	40IN01	40IN21	I1-I12	Safe digital inputs for safety functions
IOV	40IO01	40IO21	I1-I8	
RMV	40RM01	40RM21	I1-I8	
INV			IO1-IO4	Safe digital inputs Safe semi-conductor outputs
IOV			O1-O7	Safe semi-conductor outputs
RMV			K1, K2	Contact outputs each 2 safe NO
IOV			P	24V DC for the outputs Monitored voltage

6.1 Connection schematic

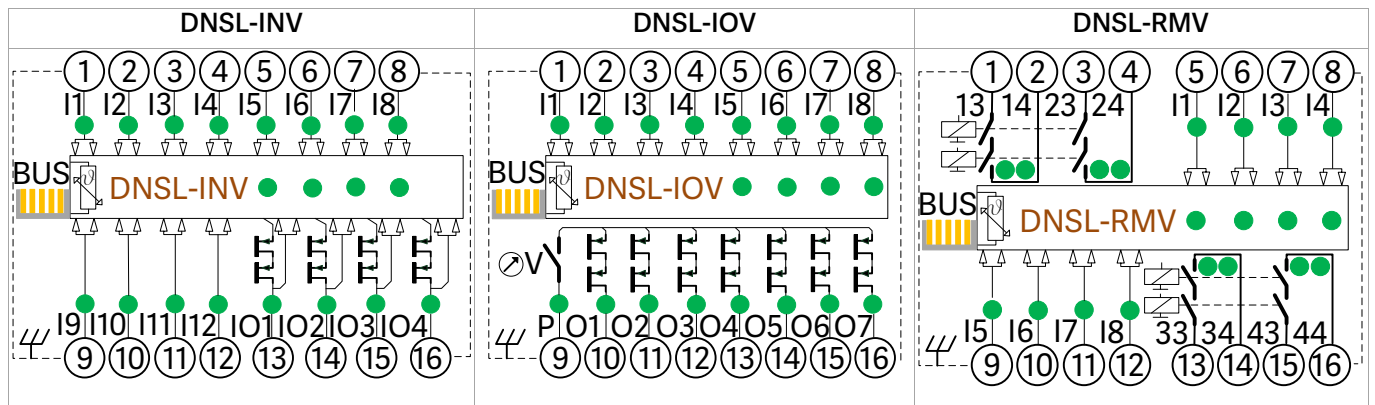

	LED Display for diagnostics		Connector to earth via DIN rail
--	-----------------------------	--	---------------------------------

6.2 Front side

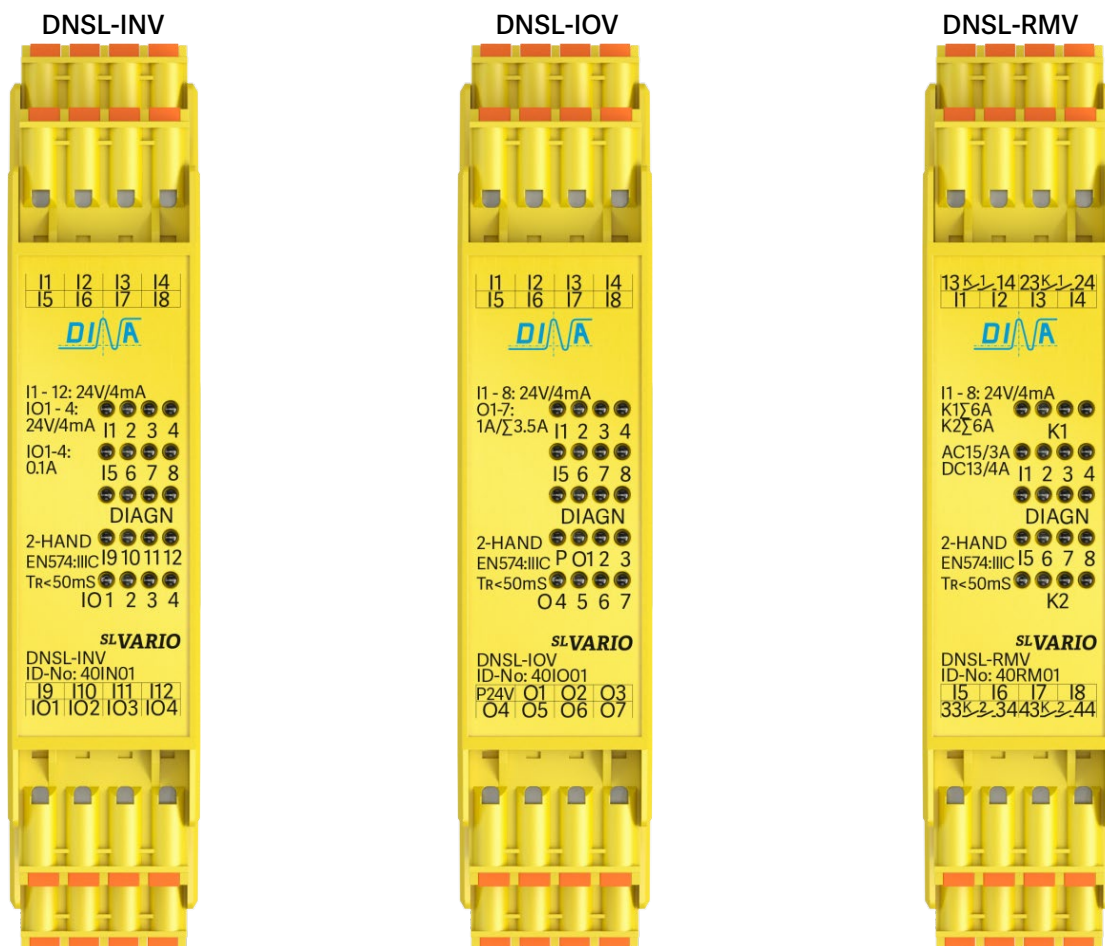

6.3 Switching status display

DNSL-INV

I1- I12	Signal = 0 V	Signal = 24 V
IO1-IO4	Signal = 0 V	Signal = 24 V
IO1-IO4	I = 0	I > 0 ≤ max.
DIAGN	links: CAN Kommunikation OK links: Keine CAN Kommunikation	2-4 rechts: Modulfunktion OK 2 - 4 rechts: Interner Fehler

DNSL-IOV

I1 - I8	Signal = 0 V	Signal = 24 V
O1 - O7	I = 0	I > 0 ≤ max.
DIAGN		Immer grün

DNSL-RMV

I1 - I8	Signal = 0 V	Signal = 24V
K1/ K2		
DIAGN		Immer grün

7 Field bus modules

	Terminal		Function	Terminal	Description
	Single	Twin			
DNSL-COV	ID-No.: 40CO03	ID-No.: 40CO23	CANopen	11-18	8 Safe digital inputs for safety functions at the field bus modules left 4 Byte input data at the field bus modules left 8 Byte output data at the field bus modules left Number of Byte is configurable
DPV	40DP03 40DP04	40DP23 40DP24	Profibus DP		
ECV	40EC03	40EC23	EtherCAT		
EPV	40EP03	40EP23	Ethernet /IP		
MOV	40MO03	40MO23	Modbus		
PLV	40PL03	40PL23	Power link		
PNV	40PN03	40PN23	ProfiNET		

Feld bus modules with 10 terminal inputs

DPV	40DP05		Profibus DP	11-110	10 Safe digital inputs for safety functions at the field bus modules left
ECV	40EC05		EtherCAT		4 Byte input data at the field bus modules left
MOV	40MO05		Modbus		16 Byte output data at the field bus modules left

7.1 Usage

- The digital inputs can be used for safety functions. See inputs for safety functions
- The field bus modules are for data transfer between SL-VARIO application and machine control via the field bus master.
- The data can be for diagnostics respectively for not safety relevant control signals
- Data transfer from or to the machine control are possible.

7.2 Connection schematic

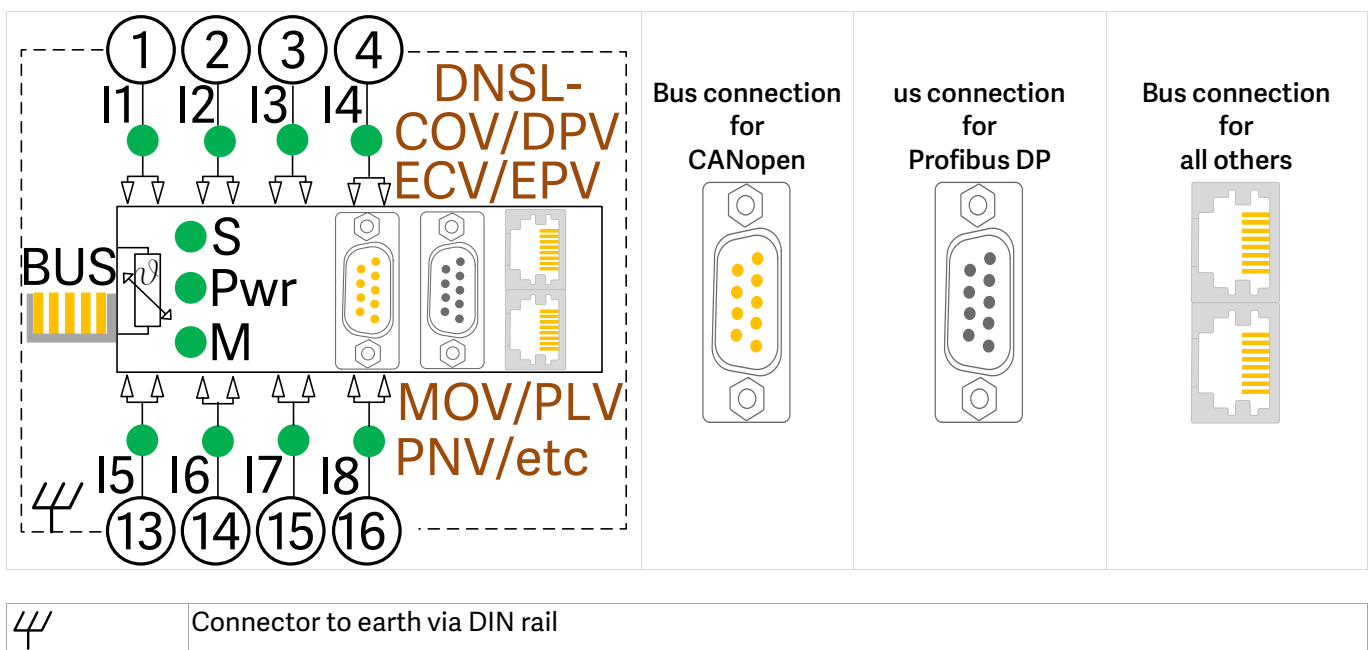

7.3 Front side

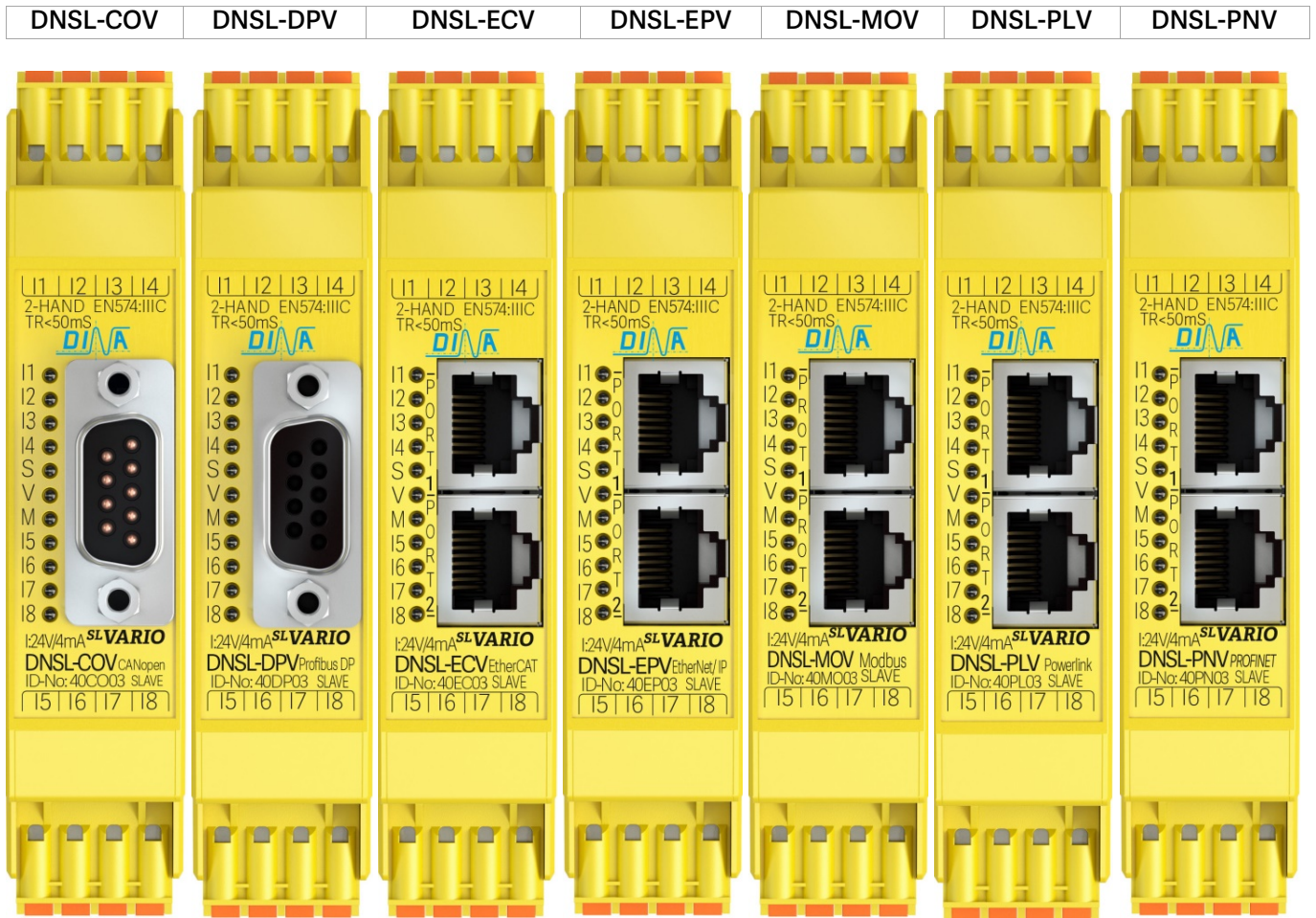

7.4 Switching status display

	I1 – I8		Signal = 0V		Signal = 24V
	I1 – I10		Signal = 0V		Signal = 24V
	V		Pwr = 0 V		Pwr = 24 V
	M/ S		Error		OK

8 Cascade module DNSL-CMV

DNSL-CMV	Terminal		Anschluss	Description
	Single	Twin		
	ID-No.: 40CM03	ID-No.: 40CM23	AD1- AD4	Addressing inputs
			B	Input to adapt the bus system. In the periphery unit it must be connected to 24V DC.
				Communication interface between the base unit with the periphery unit
			A1, A2	Power supply 24V DC
			S1, S2	Interface grounding, module grounding via the rail

8.1 Usage

- Mounting of the modules of an application on different places to avoid costly wiring
- A cascade contains a base unit BU with central module and up to 5 periphery units PU
- In every unit is one DNSL-CMV.
- In the PU DNSL-CMV replaces the central module.
- Serial or starry cascade is possible.
- The units are via patch cables connected together.
- The maximal length of all patch cables is 100 m.
- The power supply 24V DC happens via A1/ A2 at CMV if there is patch cable length > 10 m.
- The addressing of the first FM in the PU happens via AD1–AD4 at CMV.
- The addressing of the follow modules in the PE happens automatically.
- 15 modules are possible in one application.
- The binary code enables 1 to 14 addresses.
- 0 and 15 are not allowed.
- B-input must be connected to 24V DC at periphery units.

Base units with the central module, necessary function modules and the cascade module DNSL-CMV	Periphery unit with DNSL-CMV and necessary function modules	Periphery unit with DNSL-CMV and necessary function modules
--	---	---

8.2 Serial and star shape cascade

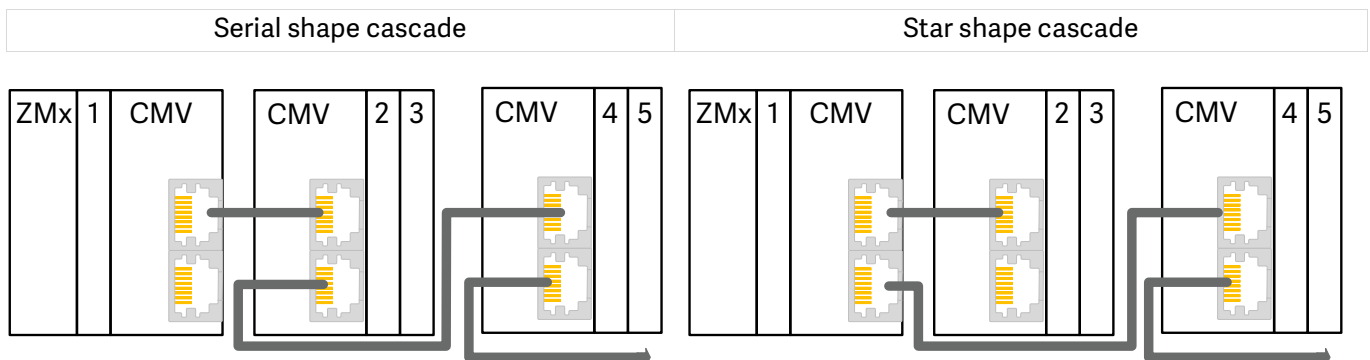

8.3 Addressing of the function modules

- The addressing of the first FM in the PU happens via AD1 – AD4 at CMV.
- The address of the follow modules in the PU happens automatically.

AD	BE/BU	CMV	PE1/PU1	PE2/PU2	PE3/PU3	AD1	AD2	AD3	AD4
0	ZMV								
1	FM1								
2	FM2								
3	FM3								
	CMV0								
4		CMV1	FM4						
5	auto		FM5						
6	auto		FM6						
7		CMV2		FM7					
8	auto			FM8					
9		CMV3			FM9				
10	auto				FM10				
11	auto				FM11				

By cascade modules we recommend the usage of patch cable with plugs from the company Hirose with the ID-no.: TM11AP-88P (61) to ensure the quality.

8.4 Front and side view

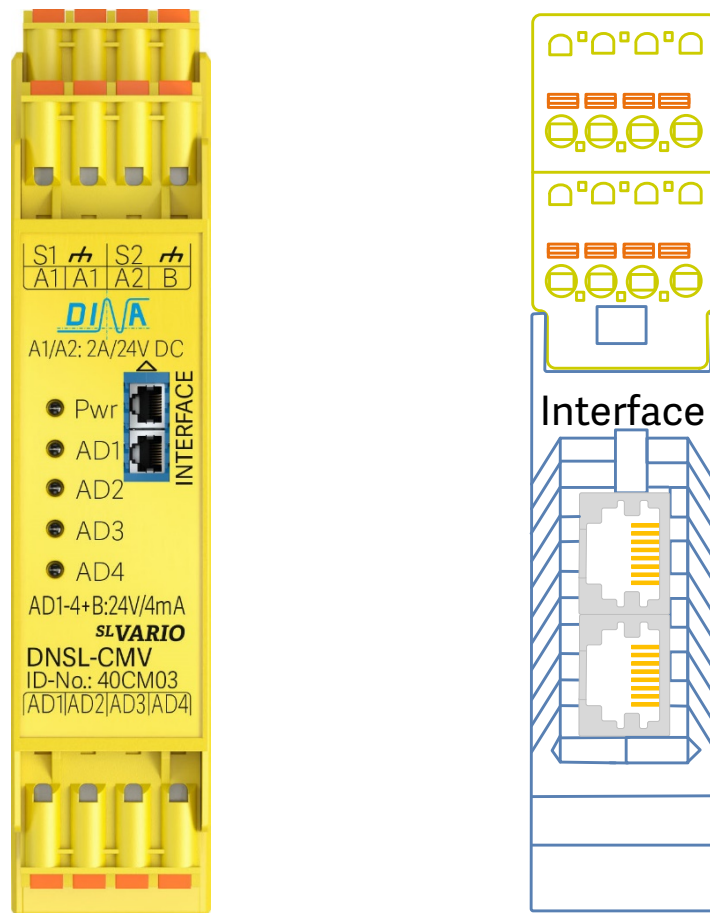

8.5 Switching status display

Pwr	Pwr = 0 V	Pwr = 24 V
AD1 – AD8	Signal = 0V	Signal = 24V

9 Network module DNSL-NIV

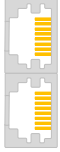
	Terminal		Connector	Description
	Single	Twin		
DNSL-NIV	ID-No.: 40NI01 40NI02	ID-No.: 40NI21 40NI22	I1-I8	Safe digital inputs for safety functions
				Communication interface
			O1-O4	Safe semi-conductor outputs
			P	24V DC for the outputs, monitored voltage
			S1, S2	Interface grounding

9.1 Usage of DNSL-NIV

- Data transfer between up to 8 applications
- For every system is one DNSL-NIV required.
- Via patch cable the applications will be contacted serial. The cable length can be max. 100 m.
- After a break of the data transfer a quit is required.
- Therefor a quit symbol in the Designer is provided.
- For data transfer 32 in- and 32 outputs.
- The configuration happens in the Designer.
- RJ45 connectors are to use for specified function only

9.2 Connection schematic

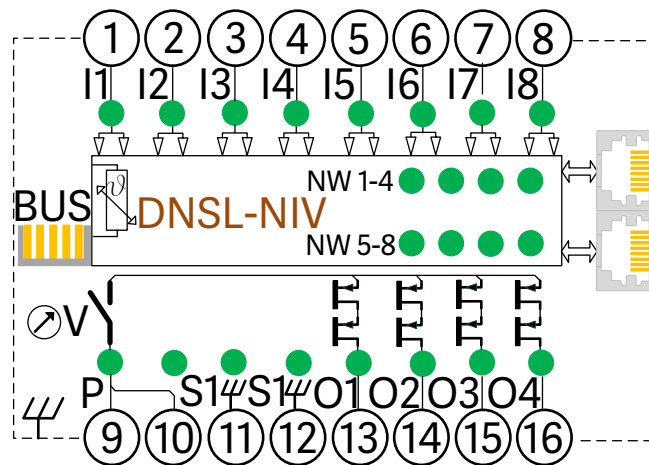

	Connector to earth via DIN rail
---	---------------------------------

9.3 Networking of SL VARIO applications

networking up to 8 applications is possible.

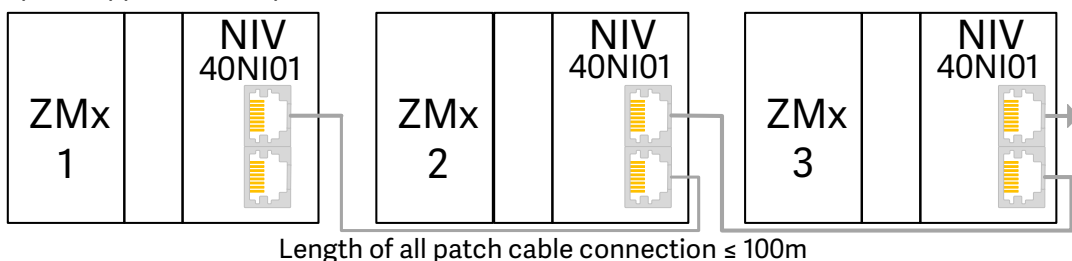

9.4 Front and side view

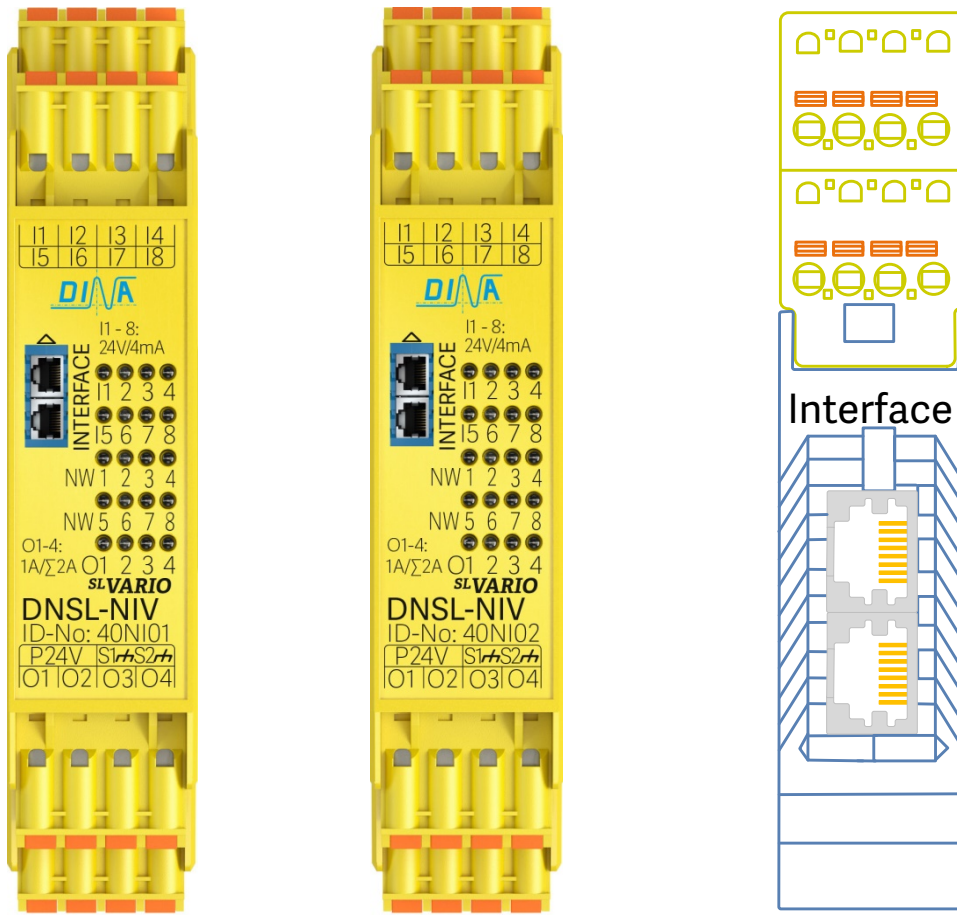

9.5 Switching status display

I1 – I8	Signal = 0V	Signal = 24V	
O1 – O4	I = 0	I > 0 ≤ max.	
NW 1 2 3 4 Network Address 1-4 for application 1-4		<p>Local participant</p>	<p>Example 2: External participant 3</p> <p>Receiving of data will be ignored Sanded data of 3 will be interpreted</p>
NW 5 6 7 8 Network Address 5-8 for application 5-8		<p>Example 1: External participant 6</p> <p>Participant 6 with data transfer</p>	<p>Example 3: External participant 8</p> <p>Participant 8 is not available</p>

The addressing of the Participants happens at the Designer. Address 1 to 8 is possible.

10 Network module DNSL-NRV

	Terminal		Connector	Connector	Description
	Single	Twin			
DNSL-NRV	ID-No.:	ID-No.:			Communication interface
	40NR01	40NR21			
				MH, ML, SH, SL	
			A1, A2		Power supply 24V DC

10.1 Usage of DNSL-NRV

- Networking up to 8 applications is possible.
- The cable length between the applications can be up to 150 m.
- The RJ45 plugs placed at the side of NRV are only to connect with the RJ45 plugs at NIV (40NI02).
- The RJ45 plug at the front side of NRV is to connect with the RJ45 plug at NIV (40NI01).
- The connection of the four network plugs at the side of NRV is displayed via LED, at the front side is not displayed.
- The connection from NRV to NIV (40NI02) can be happen at RJ45 plug 1 or 2.

10.2 Connection schematic

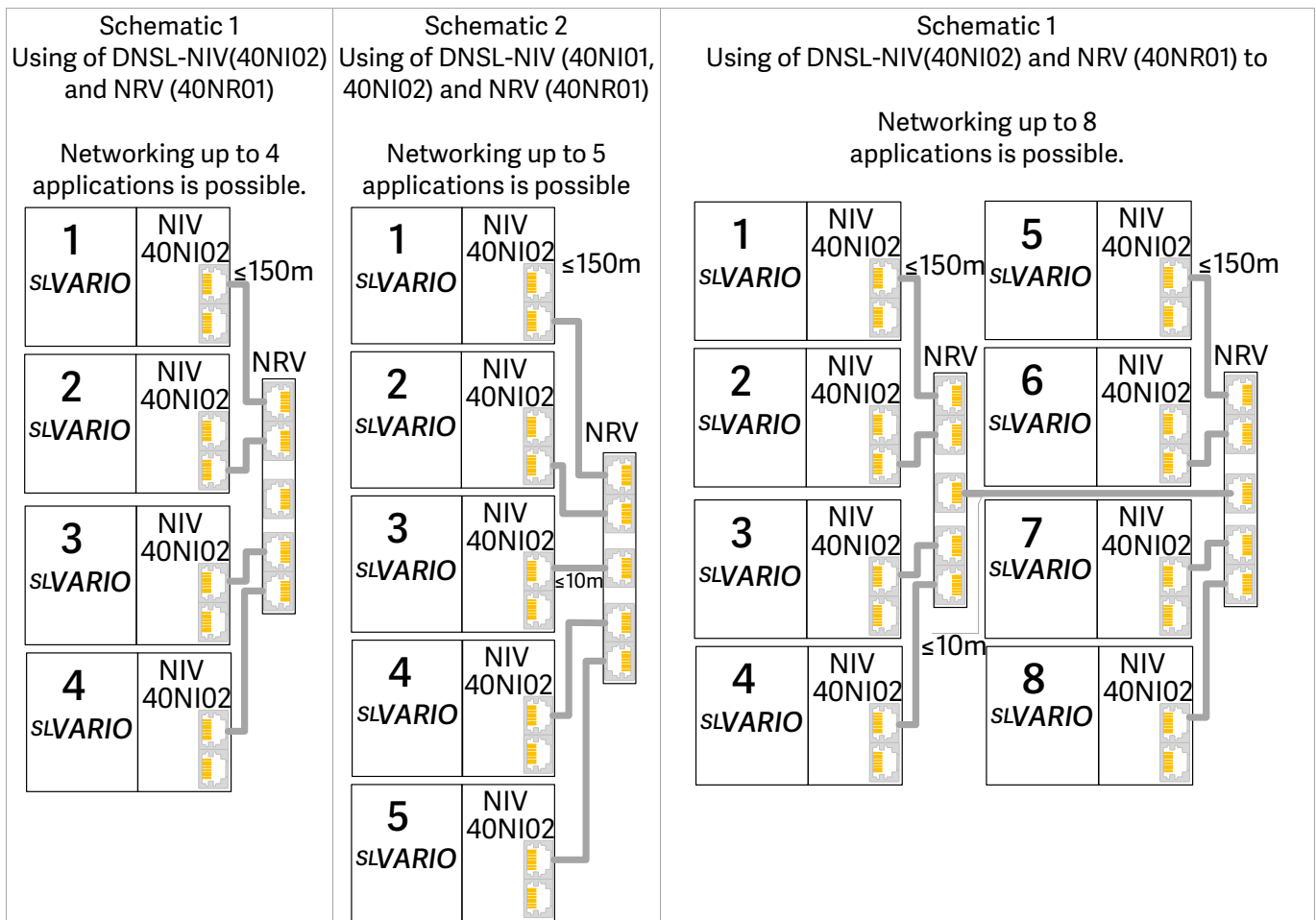

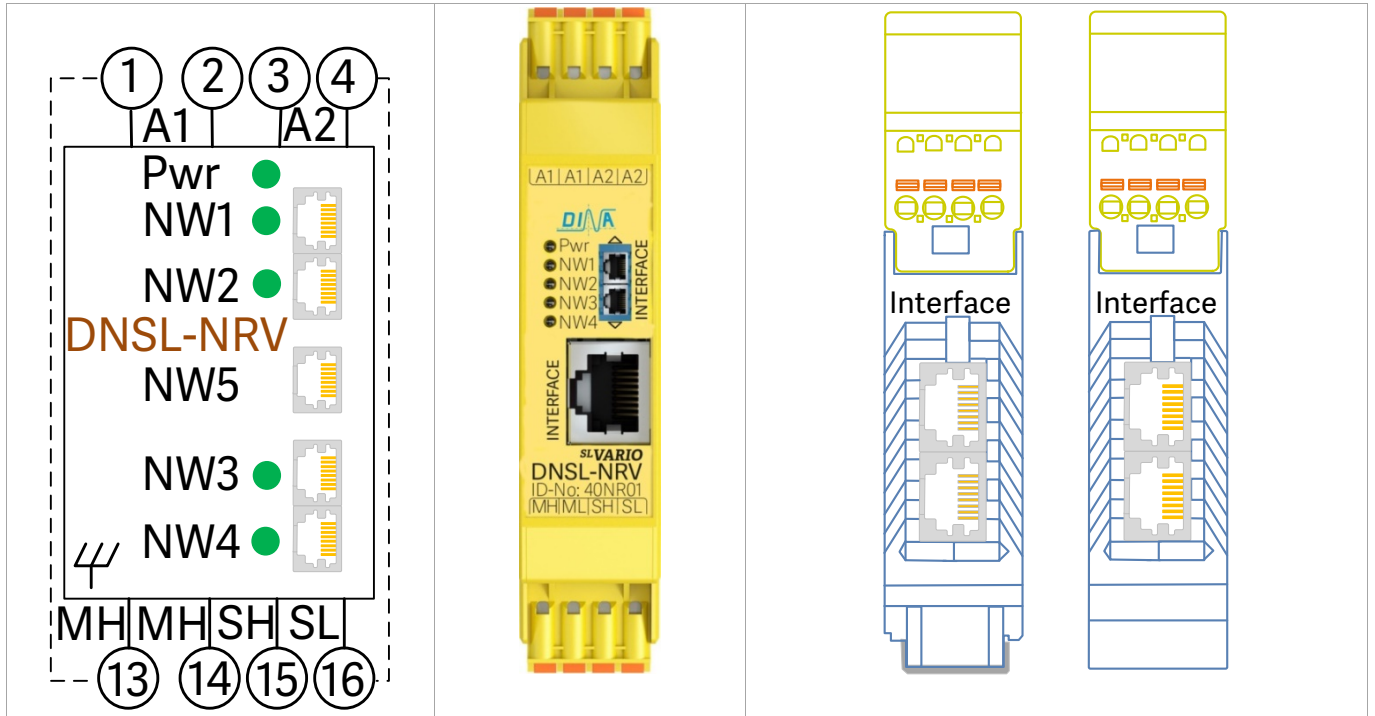

By network modules we recommend the usage of patch cable with plugs from the company Hirose with the ID-no.: TM11AP-88P (61) to ensure the quality.

10.3 RJ45 Female connection schematic, front and side view

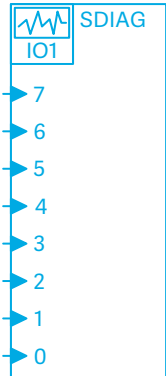

	Connector to earth via DIN rail
--	---------------------------------

11 Diagnostics module DNSL-DMV

Designer Symbols	Terminal		Terminals	Description
	Single	Twin		
	ID-No.: 40DM01	ID-No.: 40DM21	A1/ A2	Power supply 24V DC (A1: 24V, A2: 0V)
<p>3x available</p> 	<p>Front view</p> 		Rx	Serial data terminal to connect with IO1-terminal at central module. The maximal wire length is 100m.
			SW	This terminal has to be connected with Rx-terminal if power supply is not available. In this case the module will be supplied Rx-terminal. (single-wire-function mode) The A2-terminal has to be connected to 0V or earth. A1/ A2 is used to supply the module if power supply is available. The SW-terminal remains disconnected.
			P1	An activation of this terminal (24V DC) mirrors the valence of the LED SC10–SC17 and SC20-SC27 (hexadecimal display) The outputs O1-O2 are independent of this displaying.
			P2	An activation of this terminal (24V DC) displays the switching status of the outputs using the LED SC20-SC27. The LED are green if the outputs are switched on.
			P3, P4	Reserved for future functions
			O1-O8	Diagnostics outputs positive switching to transfer switching status of SL VARIO to a higher control. Switching current, power supply via Rx-terminal: ≤ 10mA Switching current, power supply via A1/ A2-terminals: ≤ 200mA

11.1 DNSL-DMV usage

- DNSL-DMV can be used as a Diagnostics module for SL VARIO mounted another place with IP54 environment.
- The actuation of data for LED display and outputs is available every second.
- Using the interface (IO1-terminal) at the central module the switching status data can be transferred to the Rx-terminal at DNSL-DMV.
- The switching status of SL VARIO can be displayed via the LED block SC10-SC17 and SC20-SC27 and by means of the outputs O1-O8 can be transferred to a higher control.
- The configuration of these functions taken place at the Designer (single wire-function mode).
- For this there are 3 elements available each with 8-bit length. (SDIAG1, SDIAG2 and SDIAG3)
- The central module recognizes the configuration of (SDIAG 1-DIAG3) in the Designer and switches the IO1-terminals to a serial Interface output to transfer diagnostics data.
- In the symbol every diagnostics bit-input can be described.
- The Designer button (1 wire diagnostics) must be activated if the module is supplied by Rx-terminal. Then it is active for all 3 elements.
- SDIAG1/ SC10-SC17 control LED block SC10-SC17
- SDIAG2/ SC10-SC17 control LED block SC20-SC27
- SDIAG3/ SC10-SC17 control the outputs O1-O8

11.2 DNSL-DMV display

- LED SC10-SC17 and SC20-SC27 are green when the related bit at the Designer symbol is active.
- LED Rx is flashing green during data reception, always green when the voltage 24V is constantly connected to the Rx-terminal and dark without any signals at Rx-terminal
- LED A1 is green if the power supply is available.
- LED S1 and S2 are reserved for future functions.

Diagnostics module DNSL-DMV

• Inputs for safety functions

The following table shows **SLVARIO** modules with their available inputs (I) and in- outputs (IO). These can be used for different safety and not safety relevant functions.

Module s DNSL	Inputs																In-, outputs				Designer Symbol
ZMV / ZMVA	I1	I2	I3	I4	I5	I6	I7	I8	I9	I10	I11	I12	I13	I14	I15	I16	IO1	IO2	IO3	IO4	
ZMVD /ZMVK	I1	I2	I3	I4	I5	I6	I7	I8	I9	I10	I11	I12	I13	I14	I15	I16	IO1	IO2	IO3	IO4	
ZMVD	I17	I18	I19	I20	I21	I22	I23	I24	I25	I26	I27	I28	I29	I30	I31	I32					
ZMVD	I33	I34	I35	I36	I37	I38	I39	I40	I41	I42	I43	I44	I45	I46	I47	I48					
INV	I1	I2	I3	I4	I5	I6	I7	I8	I9	I10	I11	I12					IO1	IO2	IO3	IO4	
DSV / DSV2	I1	I2	I3	I4	I5	I6	I7	I8													
DSIV	I1	I2	I3	I4	I5	I6	I7	I8													
DRV	I1	I2	I3	I4	I5	I6	I7	I8													
SIV	I1	I2	I3	I4	I5	I6	I7	I8													
IOV / RMV	I1	I2	I3	I4	I5	I6	I7	I8													
Feldbusse	I1	I2	I3	I4	I5	I6	I7	I8													
NIV	I1	I2	I3	I4	I5	I6	I7	I8													

11.3 Analogue inputs at the central module

- I1 to I8 safe inputs for safety shutdown mats
- I1 to I8 safe analogue inputs for 0 to 10V
- I1 to I8 safe analogue inputs for 4 to 20mA

11.4 Inputs for function mode selection switch (FMSS) at central module

- 2 FMSS functions are at the central module available.
- Any inputs at SL VARIO and internal designer wiring can be used also.
- One switching position can be selected. No output signal if more or none

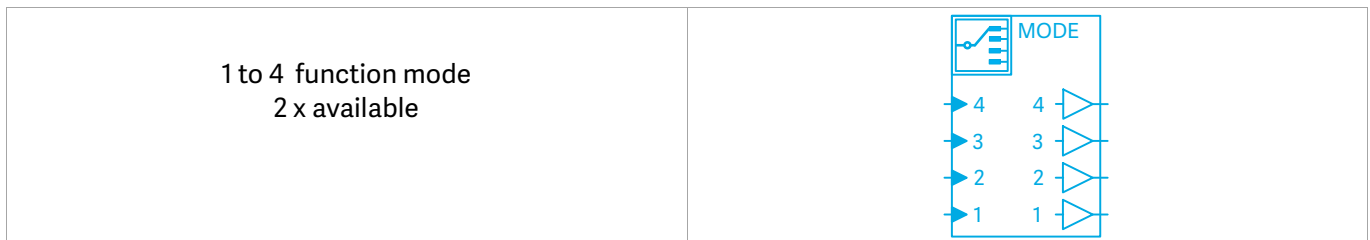

11.5 Inputs for Tow-Hand function according EN 574: Type IIIC

Activate both buttons within 500ms.

Response time: < 50ms

Modules	Terminal	Control	Function diagram	Designer symbol
DNSL-	E1 Q1 E2 Q2			
ZMV / ZMVA	I1 I2 I3 I4			
ZMV / ZMVA	I5 I6 I7 I8			
ZMVD / ZMVK	I1 I2 I3 I4			
ZMVD / ZMVK	I5 I6 I7 I8			
DSV / DSV2	I1 I2 I3 I4			
DSIV	I1 I2 I3 I4			
DRV	I1 I2 I3 I4			
INV / IOV	I1 I2 I3 I4			
RMV	I1 I2 I3 I4			
Field busses	I1 I2 I3 I4			

11.6 Inputs for shut down mats, switch rails and bumpers at central module

- | | |
|--|--|
| <ul style="list-style-type: none"> Up to eight short generating shutdown mats, switch rails or bumpers can be monitored safely. The sensors have to be connected to I1-I8 accordingly to the schematic down. The output SM at the symbol has to be activated via the quit symbol. The quit symbol activate all available shutdown mats. | <ul style="list-style-type: none"> Mix configuration of the inputs I1-I8 is possible. The reaction time is $\leq 20\text{ms}$ Power supply: 24V DC +10%, -15% (PLV) Safety category 4/ PLe For other specifications see general technical data |
|--|--|

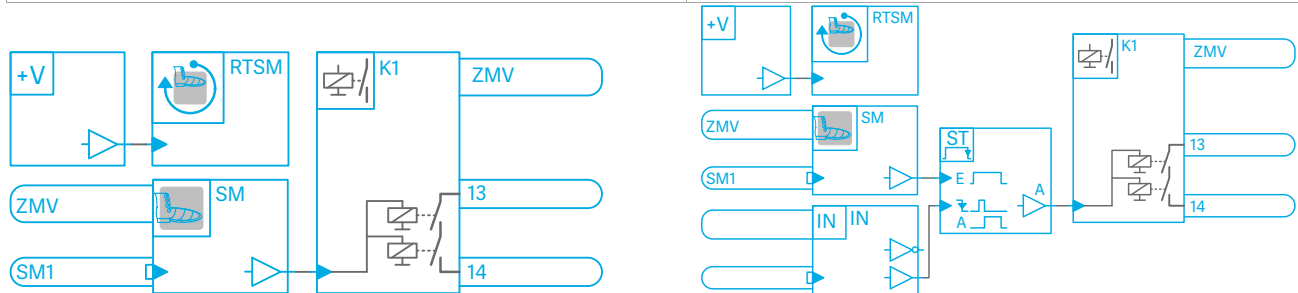
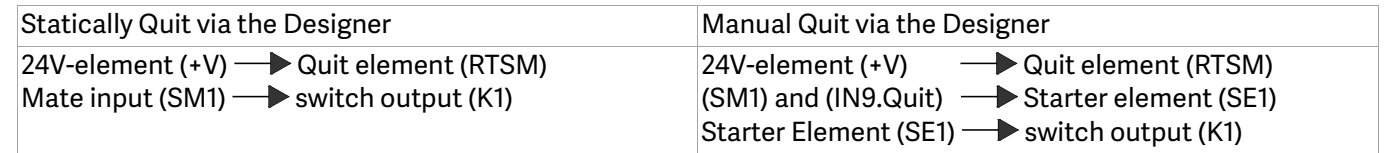
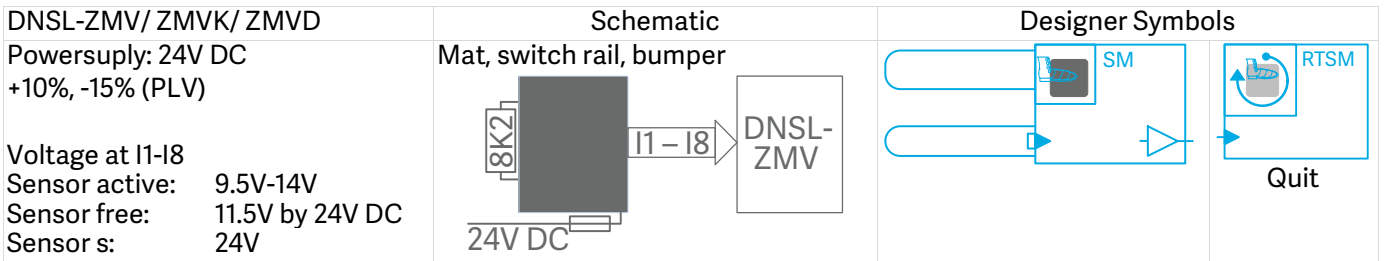

11.7 Important notes with using of shutdown mats, switch rails and bumpers

- The unit may only be installed and operated by those who are qualified electrical engineers or have received sufficient training and are familiar with both these instructions and the current regulations for safety at work and accident prevention.
- At begin of the implementing and in frequently time distance the necessary checks (function, status, rating and arrangement) must be undertaken of the user depending of the signal generator at the safety device.
- The safety function must be required every month if there is performance level (e) and every year if there is PLd is required by using contact outputs.
- The maximal length of the connection wire is depended of the environment and the cross section of the wire. Recommended maximal length 100 m
- The minimal safety distance of the signal generator of the protection device has to be determined according of DIN EN ISO 13855.
- The details in the instruction manual of the used signal generator must be considered and observed.
- Function parameters of the signal generator and control unit must be observed.
- Only signal generators with minimum 500.000 switch cycles respectively switch rails with minimum 11.000 switch cycles can be used.
- The contact load of the switch device outputs is to determinate according part: 17.5, page 38 to arrive the necessary switch cycles.
- The reaction time of the whole system is to consider.
- At the end of the service life the units have to be replaced.

- The replaced units have to be properly disposed.
- Faults and diagnostics via switching status LED (page 12), the online diagnostics via the USB interface at the control unit.

Follow details have to be considered:
 Safety regulation and important notes and validation (page 7), general technical data (page 37 and 38), details in the Instruction manual of SL VARIO Designer

11.8 Inputs for Safety circuits (SC) with manual Quit

Safety circuits (SC) / input (I)

Module	SC1			SC3			SC5			SC7		
DNSL-ZMV/ A / D/ K	I1	I2	I3	I5	I6	I7	I9	I10	I11	I13	I14	I15
DNSL-INV	I1	I2	I3	I5	I6	I7	I9	I10	I11			
DNSL-DSV/ DSV2	I1	I2	I3	I5	I6	I7						
DNSL-DSIV/ DRV/ SIV	I1	I2	I3	I5	I6	I7						
DNSL-IOV/ NIV/ RMV	I1	I2	I3	I5	I6	I7						
Field bus	I1	I2	I3	I5	I6	I7						

Module	SC8			SC9			SC10			SC11			SC12		
DNSL-ZMVD	I17	I18	I19	I20	I21	I22	I23	I24	I25	I26	I27	I28	I29	I30	I31

Modul	SC13			SC14			SC15			SC16			SC17		
DNSL-ZMVD	I33	I34	I35	I36	I37	I38	I39	I40	I41	I42	I43	I44	I45	I46	I47

Example for emergency stop function with manual Quit

The control happens: parallel static, parallel via clock signal from SL VARIO or static antivalent.

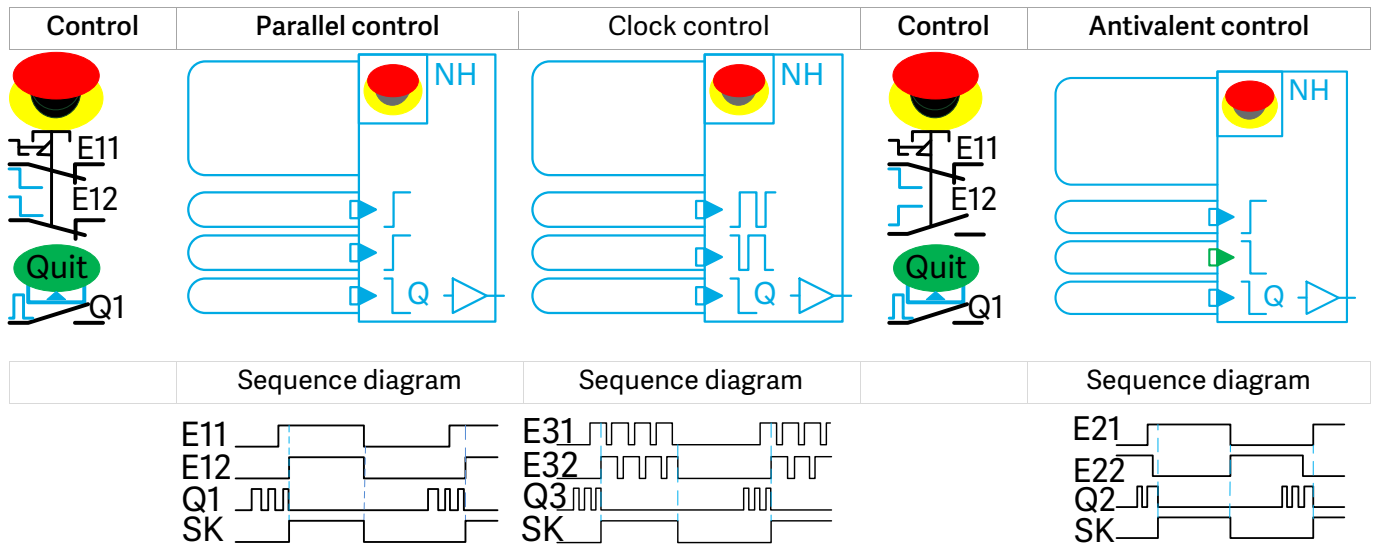

Clock: see SL VARIO outputs for clock.

11.9 Inputs for Safety circuits (SC) with Quit via Q

- The quit signal is created in the Designer and wired to Q-input at the symbol.
- The quit signal happens via a terminal input, input at the field bus or a virtual output.

Safety circuits (SC) / input name (Q) / input (I)

Module	SC1			SC2			SC3			SC4			SC5			SC6			SC7			SC8		
DNSL-ZMV/ A / D/ K	I1	I2	Q	I3	I4	Q	I5	I6	Q	I7	I8	Q	I9	I10	Q	I11	I12	Q	I13	I14	Q	I15	I16	Q
DNSL-INV	I1	I2	Q	I3	I4	Q	I5	I6	Q	I7	I8	Q	I9	I10	Q	I11	I12	Q						
DNSL-DSV/ DSV2	I1	I2	Q	I3	I4	Q	I5	I6	Q	I7	I8	Q												
DNSL-DSIV/ DRV/ SIV	I1	I2	Q	I3	I4	Q	I5	I6	Q	I7	I8	Q												
DNSL-IOV/ NIV/ RMV	I1	I2	Q	I3	I4	Q	I5	I6	Q	I7	I8	Q												
Field bus	I1	I2	Q	I3	I4	Q	I5	I6	Q	I7	I8	Q												

Module	SC9			SC10			SC11			SC12			SC13			SC14			SC15			SC16		
DNSL-ZMVD	I17	I18	Q	I19	I20	Q	I21	I22	Q	I23	I24	Q	I25	I26	Q	I27	I28	Q	I29	I30	Q	I31	I32	Q

Modul	SC17			SC18			SC19			SC20			SC21			SC22			SC23			SC24		
DNSL-ZMVD	I33	I34	Q	I35	I36	Q	I37	I38	Q	I39	I40	Q	I41	I42	Q	I43	I44	Q	I45	I46	Q	I47	I48	Q

Example for permission function with quit via Q-input

The control happens: parallel static, parallel via clock signal from SL VARIO or static antivalent.

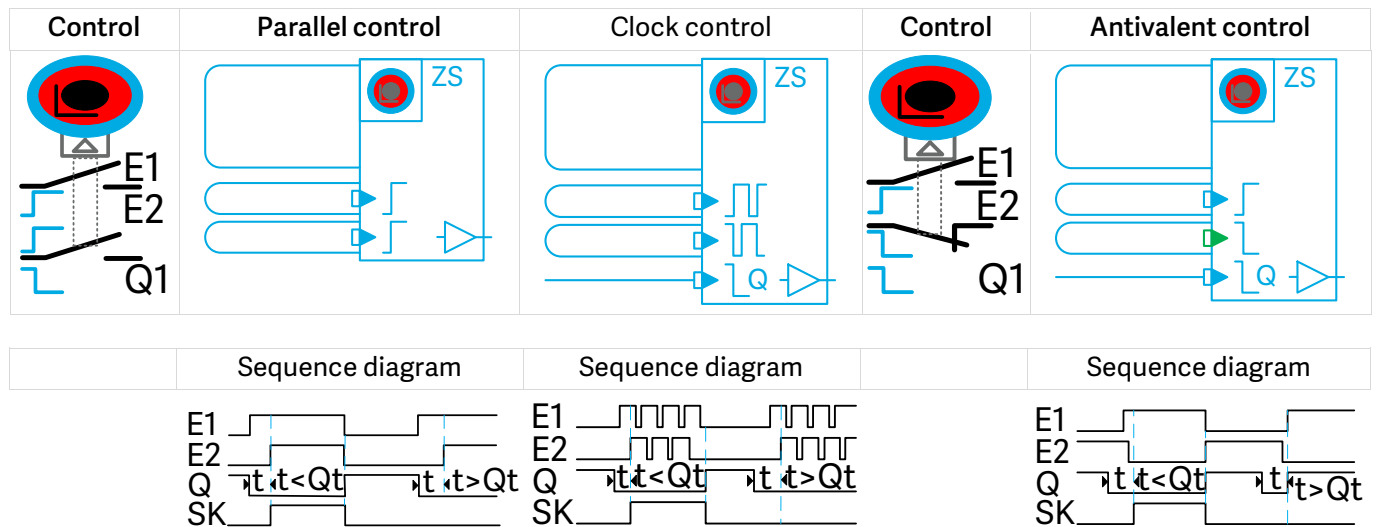

Qt: E1 and E2 have to be activated within 500ms.

Clock: see SL VARIO outputs, clock outputs

11.10 Quit of safety circuit (SC)

- Selection „with falling edge“: The quit signal has to have change \downarrow independent from the source.
- Selection „with High level “: The quit signal can be permanent independent from the source.
- The quit buffer time can be 500ms or no buffer.
- Selection at the Designer for test of SC after Pwr-ON:

Needed: a switch OFF/ ON of the safety circuit

Needless: a switch OFF/ ON of the safety circuit

11.11 Inputs for Safety circuits (SC) without Quit

Safety circuits (SC) / input (I)

Module	SC1		SC2		SC3		SC4		SC5		SC6		SC7		SC8	
DNSL-ZMV / A / D / K	I1	I2	I3	I4	I5	I6	I7	I8	I9	I10	I11	I12	I13	I14	I15	I16
DNSL-INV	I1	I2	I3	I4	I5	I6	I7	I8	I9	I10	I11	I12				
DNSL-DSV/ DSV2	I1	I2	I3	I4	I5	I6	I7	I8								
DNSL-DSIV/ DRV/ SIV	I1	I2	I3	I4	I5	I6	I7	I8								
DNSL-IOV/ NIV/ RMV	I1	I2	I3	I4	I5	I6	I7	I8								
Field bus	I1	I2	I3	I4	I5	I6	I7	I8								

Module	SC9		SC10		SC11		SC12		SC13		SC14		SC15		SC16	
DNSL-ZMVD	I17	I18	I19	I20	I21	I22	I23	I24	I25	I26	I27	I28	I29	I30	I31	I24

Module	SC17		SC18		SC19		SC20		SC21		SC22		SC23		SC24	
DNSL-ZMVD	I33	I34	I35	I36	I37	I38	I39	I40	I41	I42	I43	I44	I45	I46	I47	I48

Example for safe cover without Quit

The control happens: parallel static, parallel via clock signal from SL VARIO or static antivalent.

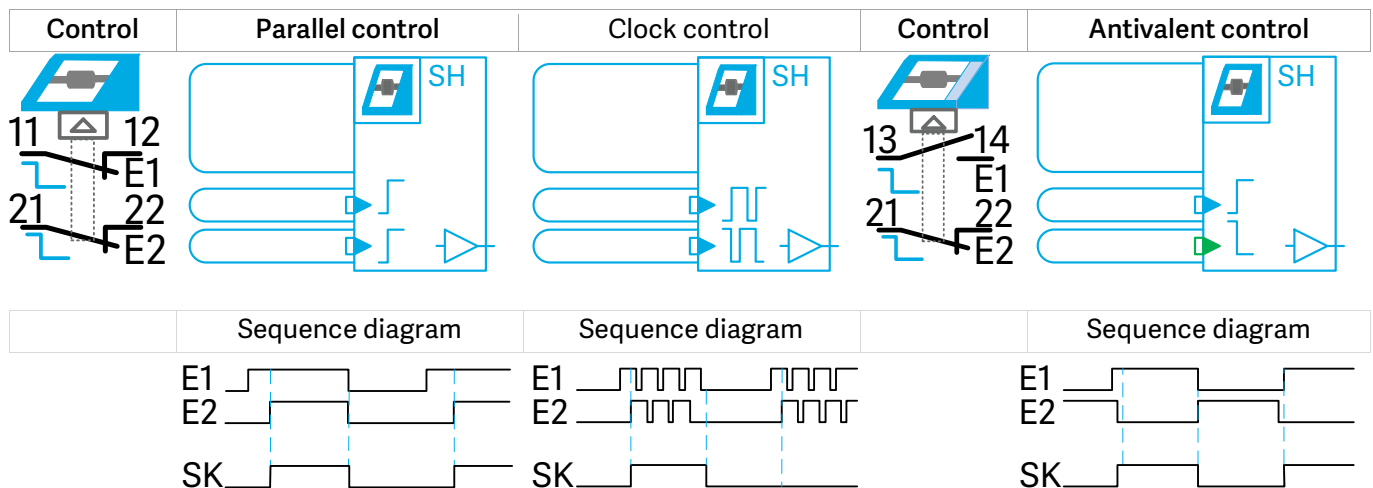

12 Data in- and outputs at the field bus

Module	Input data	Designer Symbol	Output data	Designer Symbol
DNSL-COV DNSL-DPV DNSL-ECV DNSL-EPV DNSL-MOV DNSL-PLV DNSL-PNV	FBI1.1 - FBI1.8 ▼ FBI4.1 - FBI4.8	IN 	FBO1.1 - FBO1.8 ▼ Out FBO16.1 - FBO16.8	

13 Inputs for standstill and speed monitoring

13.1 Inputs for standstill and speed monitoring at the central module

Example 1:

- 4 one-channel monitoring each with one sensor
sensor of first monitoring connected to I9, second to I10, third to I11 and forth to I12
- Monitoring of standstill and speed in different operating modes.
- One safe monitoring with a HTL incremental measuring system connected to the inputs A to I13, -A to I15, B to I14 and -B to I16
- Monitoring of standstill, speed, position, direction and break in different operating modes is possible.
ID-No.: 40ZM03, 40ZM23, 40ZM04, 40ZM 24 only
- One-channel symbol is the left corner green, safe yellow

Gear/ Sensor	One-channel monitoring (1 – 4)		Safe monitoring (5)	Functions	
		Standstill Speed	<p>HTL Measuring system</p>		Brake Standstill Speed Direction

Example 2

- 3 safe standstill and speed monitoring
- One safe monitoring with 2 sensors connected to the inputs I9 and I10.
- One safe monitoring with 2 sensors connected to the inputs I11 and I12.
- Monitoring of standstill and speed in different operating modes is possible
- Mix one-channel and safe monitoring is possible.
- One safe monitoring using a HTL incremental measurement system connected to the inputs A to I13, -A to I15, B to I14 and -B to I16. (20-26V/ 50KHz), ID-No.: 40ZM03, 40ZM23, 40ZM04, 40ZM 24 only
- Monitoring of standstill, speed, position, direction and break in different operating modes is possible

Gear/ Sensor	Safe monitoring (1 and 2)		Safe monitoring (3)	Functions	
		Standstill Speed	<p>HTL Measuring system</p>		Brake Standstill Speed Direction

13.2 Requirements for the sensors for safe monitoring

- Two sensors for every monitoring
- At the cogwheel one sensor opposite to cog other to gap
- During standstill at least one sensor has 24V signal.
- The function of the sensors is permanently monitored.

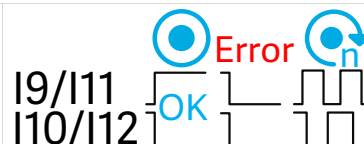

Example 3

- One safe monitoring via an incremental HTL measuring system connected to the inputs A to I9, -A to I11, B to I10 and -B to I12. ID-No.: 40ZM03, 40ZM23, 40ZM04, 40ZM 24 only
- One safe monitoring via an incremental HTL measuring system connected to the inputs A to I13, -A to I15, B to I14, and -B to I16. ID-No.: 40ZM03, 40ZM23, 40ZM04, 40ZM 24 only
- Standstill, position, direction, speed, and break can be monitored in different operating modes,

	HTL-Measuring systems	Monitoring 1 and 2	Functions
			Brake Standstill Speed Direction

13.3 Inputs for standstill and speed monitoring at the central module DNSL-ZMVD

- The central module ZMVD is available with two version one with additional four monitoring (ID-No: 44ZM01) the second with eight monitoring (ID-No: 48ZM01).
- These are mounted at the left side of the central module.
- Standstill, speed, position, direction and brake in different function modes can be monitored.
- For every monitoring an incremental measuring system is necessary.
- Sinus/ Cosine or TTL signals are possible. HTL signals are possible using DINA HTL-cable adapter
- The connector plugs for measuring systems are on the upper and lower side of the unit.
- For every monitoring is one connector plug available.

Standstill and speed monitoring with DNSL-ZMD

Measuring system connections	Sin/ Cos 1Vss or TTL 1-5V signals	Monitoring 1 to 8	Functions
<p>4 x RJ45 female plug 8x RJ45 female</p>	<p>Measuring system</p> <p>≤ 400KHz ID-No: 44ZM01 width: 67,5mm 4 monitoring ID-No: 48ZM01 width: 90mm 8 monitoring</p>		Brake Standstill Speed Direction

	MT: non monitored automatic function mode
	F13: monitored automatic function mode
	F12: monitored semi-automatic function mode
	F11: monitored tool-setting function mode

13.4 Input for safe standstill and speed monitoring at DNSL-DSV and DSV2

- Two safe monitoring are available.
- For every monitoring an incremental measuring system sinus / cosine or TTL signals is necessary.
- Standstill, position, direction, break and speed monitoring in different operating modes are possible.

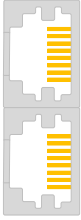
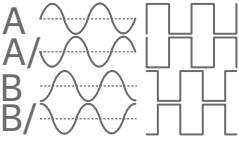
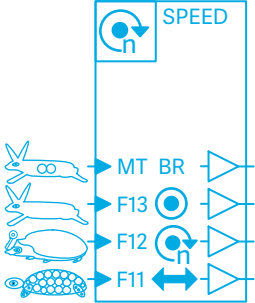
Measuring system inputs	Usage example	Function modes	Monitoring 1 and 2
 <p>Rj45 female plug</p>	 <p>≤ 500KHz</p>		<p>Monitoring 1 and 2</p> <p>Functions</p> <ul style="list-style-type: none"> Brake Standstill Speed Direction

13.5 Requirements of the incremental measuring system

Standard Sin / Cos or TTL measuring system	Standard HTL measuring system via cable adapter
<ul style="list-style-type: none"> • Amplitude 1Vpp sinus / cosine or TTL • Encoder frequency ≤ 500KHz • 2 tracks, 90° phase offset, per track 2 signals, 180° phase shifted • A direct connection between motion monitoring and measuring system is required 	<ul style="list-style-type: none"> • Amplitude 18 to 26V square wave. • Encoder frequency ≤ 500KHz • 2 tracks, 90° phase offset, per track 2 signals, 180° phase shifted • System without negated signals is possible. • A direct wire connection between motion monitoring and measuring system is required.

13.6 Two sensors measuring system with DNSL-DSV

- For every monitoring 2 positive switching sensors with antivalent signals.
- The signals of the sensors have to be connected to the RJ45 plugs at the monitoring module.
- The connection happens via two cable adapters type DNRJ45 HTL-SL.
- For the monitoring of the direction a time pitch between the impulse edges of both signals is necessary for the whole speed range. This must be considered for the mounting of the sensors.
- Time pitch and duty cycle value are not relevant.
- After power-on the LR-signal is indefinite.
- Usage of sensors with one output is possible. Here is a monitoring of the direction not possible.

13.7 Ramp monitoring with DNSL-DSV and DSV2

- The output (SAR/ BR) at the symbol is to use for the ramp monitoring of an axle.
- The speed reduction in rotation/s² respectively meter/s² and the sample rate is adjustable at the Designer.
- The sample rate is selectable 10-150ms in 10ms steps.
- Without selection is the output (BR) low.
- During speed reduction ≥ selection is (BR) high.
- During speed reduction < selection is (BR) low.
- Outputs at SL VARIO can be triggered via SAR outputs.

13.8 Inputs for standstill and speed monitoring at DNSL-DSIV

- Two safe monitoring are available.
- For first monitoring an incremental measuring system with sin/ cos 1Vss or TTL signals is used.
- For the second monitoring a SSI interface measuring system is necessary.
- A comparator function is available between the first and the second monitoring.
- Standstill, position, direction, break and speed monitoring in different operating modes are possible.
- For ramp monitoring see Designer instruction manual.

Measuring system connections	Sin/ Kos 1Vss or TTL 1-5V signals	Monitoring 1 and 2	Functions
<p>Rj45 female plug</p>	<p>Measuring system 1: $\leq 500\text{KHz}$</p> <p>Measuring system 2: SSI interface</p>		<p>Brake</p> <p>Standstill</p> <p>Speed</p> <p>Direction</p>

13.9 Input for standstill and speed monitoring at DNSL-DRV

- Two safe monitoring with resolver measuring systems.
- For every monitoring one system is necessary.
- Standstill, position, direction, break and speed monitoring in different operating modes are possible.

Measuring system connections	Resolver Measuring systems 1 - 10V	Monitoring 1 and 2	Functions
<p>Rj45 female plug</p>	<p>$\leq 1200\text{Hz}$</p>		<p>Standstill</p> <p>Speed</p> <p>Direction</p>

Setting of the resolver amplitude at DNSL-DRV
 The setting of both DIP switches is identical.

Amplitude Adjustment	1-2Vpp	2-4Vpp	4-8Vpp	8-10Vpp

13.10 Inputs for standstill and speed monitoring at DNSL-SIV

- Two monitoring with SSI interface measuring system.
- For every monitoring one system is necessary.
- Standstill, position, direction, break and speed monitoring in different operating modes are possible.

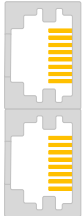
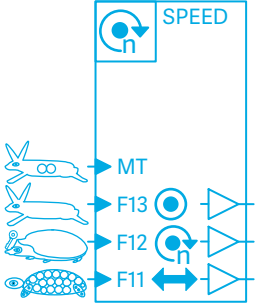
Measuring system connections	SSI-interface measuring systems	Monitoring 1 and 2	Functions
 Rj45 female plug			Standstill Speed Direction

	MT: non monitored automatic function mode F13: monitored automatic function mode F12: monitored semi-automatic function mode F11: monitored tool-setting function mode
---	---

13.11 Direction monitoring with DSV, DSV2, DSIV, DRV und SIV

- The virtual outputs (SDI ) at the Designer can be used to monitor the direction of an axle.
- SDI has high signal during standstill and while sinus is advanced. Low signal if cosine is advanced.
- The preferred direction can be selected via hardware inputs and logic elements.

13.12 Quit of speed monitoring

- After an over speed the output (SSM) has a high signal.
- After a quit via the input ( RTDS) is a high signal at the output (SSM) if the actual speed is lower than the selected.
- SSM changes to low signal with movement if no operating mode is selected.
- Selection of the operating modes happens via hardware terminal.
- To control the terminals permission-switch unit can be used as inching mode, permission key or safety cover contact

13.13 DNCO function to monitor the Peripheral speed

16 monitored speeds				64 monitored speeds					
I1	I2	I3	I4	I1	I2	I3	I4	I5	I6

- The DNCO function by DNSL-DSV, DSV2, DRV and the central module enables the monitoring of the peripheral speeds of machined parts or tools.
- 16 different speeds for two monitoring and for every operating mode or
- 64 different speeds for two monitoring during the automatic mode.
- The speeds can be entered in two frequency tables at the Designer.
- The selection of the monitored speeds happens via the bit code wiring of the terminal inputs.
- 4 inputs enable to monitor 16 speeds in all operating modes. For up to 64 speeds 6 inputs are required.
- The DNCO1 unit can be used to set these inputs.

13.14 Selection of DNCO-Multiplexer

- The configuration requires logic operations to select the frequencies in the table in the Designer.
- The logic operations can be process-related. In this case no terminal inputs are necessary.
- A DNCO-multiplexer is available for every frequency table. 16 frequencies can be selected via a multiplexer.
- The cell 00 in the table is selected if all inputs are not activated.
- The cells 01 to 15 are selectable via the input 1 to 15 at the DNCO-multiplexer.
- The first monitoring is paired with DNCO1 the second with DNCO2

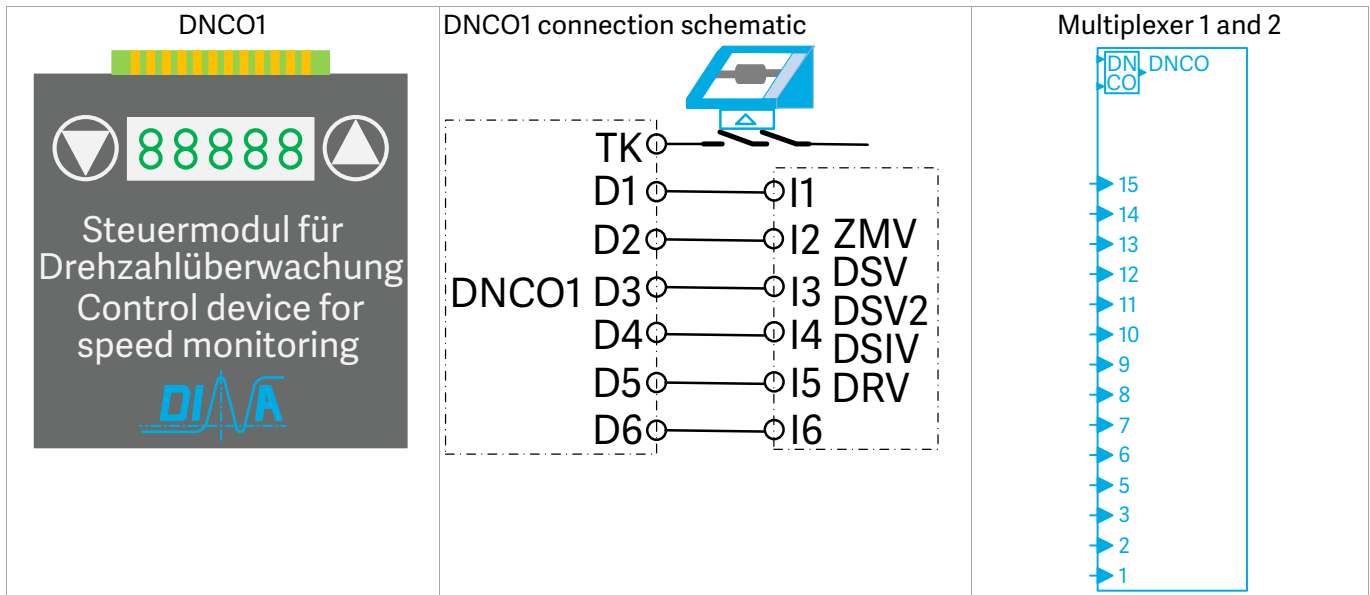

14 Cable adapter DNDA

The DNDA is used as an interconnection between the measuring system of the axle and the speed monitoring system. It is available for all CNC variations. See instruction manual cable adapter.

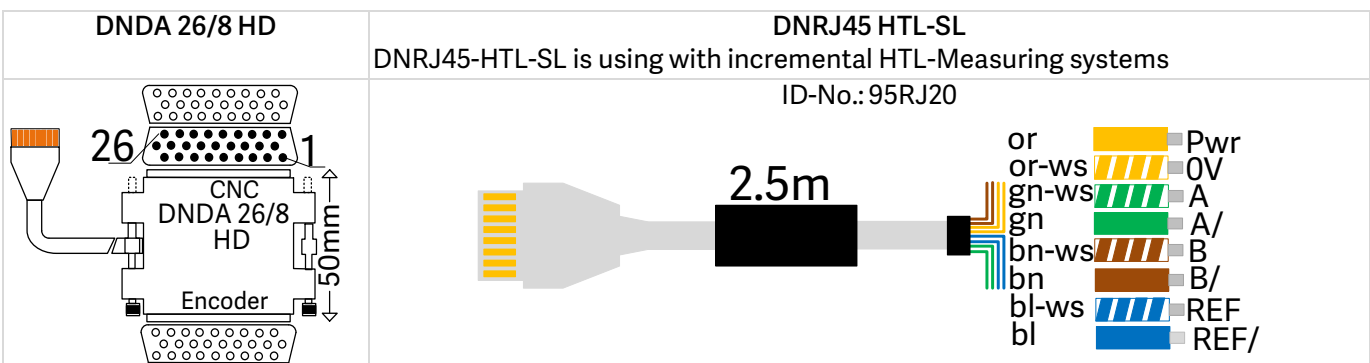
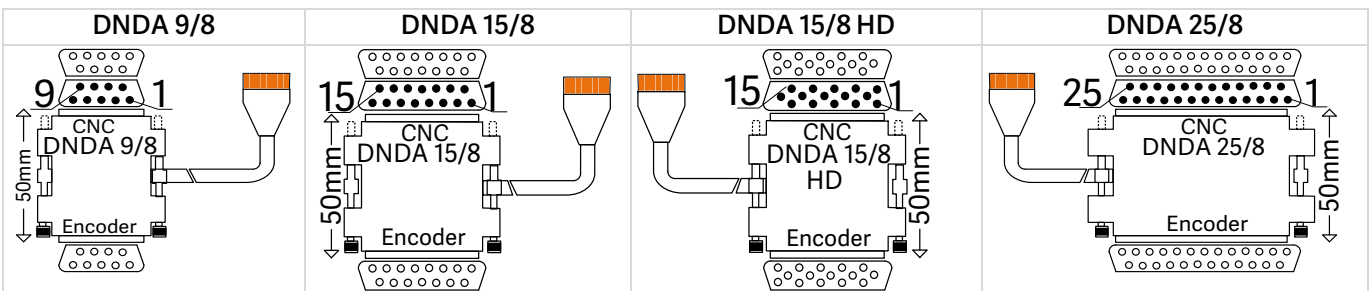

15 Outputs at SL VARIO

Short-circuit-proof positive switching semiconductor outputs

DNSL-		Switch current	P-Level	Description
ZMV / ZMVA / ZMVD / ZMVK	A1 O1-O6	1A, Σ 3A	PLe	6 safe outputs O1, O2 monitored current
ZMV / ZMVA / ZMVD / ZMVK	IO1-IO4	0.1A Σ 0.4A	PLe	4 clock outputs 4 safe outputs 4 safe digital inputs
DSV / DRV	P O1/ O2	0.25A Σ 0.4A	PLc	2 clock or switching outputs
DSV / DRV	P O3-O7	1A Σ 2.5A	PLe	5 safe outputs O1, O4 also clock outputs
DSV2 / DSIV / IOV	P O1-O7	1A Σ 3.5A	PLe	7 safe outputs O1-O4 also clock outputs
SIV / NIV	A1 IO1-IO4	1A Σ 2A	PLd	4 safe outputs
INV	P IO1-4	0.1A	PLe	4 safe or clock outputs

Safe contact outputs

DNSL-		Switch current	P-Level	Description
ZMV / ZMVA / ZMVD / ZMVK	K1 13 -14 K2 23 -24	$\geq 10\text{mA}$ $\leq 6\text{A}$ $\Sigma K1+K2: 6\text{A}$	PLe	2 safe NO contact DC13: 24V/ 2A AC15: 230V/ 3A 40ZM31/ 32 not available
ZMVK	K3 33 -34 43 -44 K4 53 -54 63 -64 K5 73 -74 83 -84 K6 93 -94 103 -104	$\geq 10\text{mA} \leq 6\text{A}$ $\Sigma K3+K4: 6\text{A}$ $\Sigma K5+K6: 6\text{A}$	PLe	Output extension 4 outputs each 2 safe NO contacts DC13: 24V/ 5A
DNSL-RMV	K1 13 -14 23 -24 K2 33 -34 43 -44	$\geq 10\text{mA}$ $\leq 6\text{A}$ $\Sigma K1+K2: 6\text{A}$	PLe	2 outputs each 2 safe NO contacts DC13: 24V/ 4A AC15: 230V/ 3A

Outputs

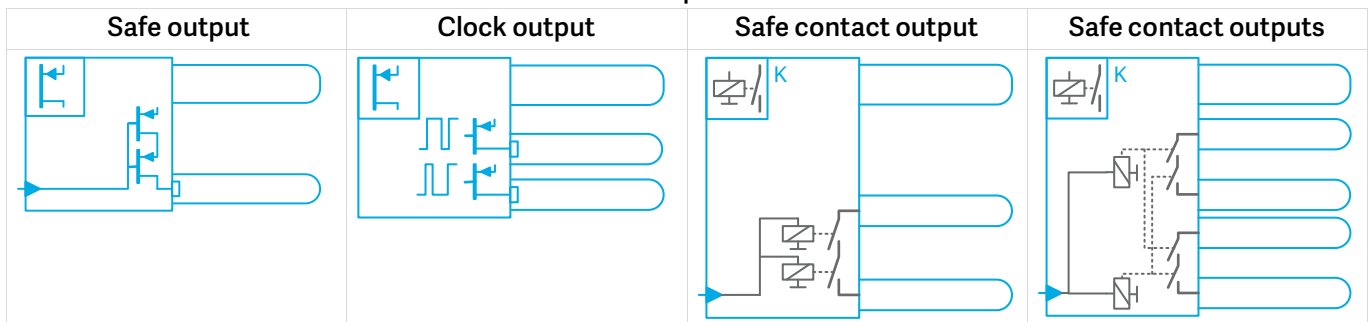

The configuration of the outputs happens at Designer.
A lot of diagnostics functions are available. This is useful for the setting-up operation and debugging.

16 General technical data

16.1 Electrical characteristics

Operation voltage via A1, A2 at ZMV, ZMVK	24V DC, -15% + 10% for all modules, ≤10% Ripple
Input current at A1	≤ 4A / internal fuse: 6A

DNSL-	ZMV	ZMVA	ZMVD	ZMVK	DSV	DSV2	DSIV	DRV
Power consumption in W	2.9	3.0	3.0	7.7	2.5	2.5	2.5	2.5
Wight in g	350	450	450	570	130	130		130







DNSL-	SIV	INV	IOV	CMV	NIV	NRV	RMV	Feld Bus
Power consumption in W	2.2	1.7	2.2	0.5	2.2	0.5	4.8	1.0
Wight in g	130	130	130	130	130	130	140	130

16.2 Environment conditions

Operating temperature: -10 +55°C	Storage temperature: -40 +85°C
High of usage location	2000m over sea level
Vibration resistance 3 axle	Sinus 10–55Hz, 0,35mm, 10 cycles, 1 octave /min
Shock resistance 3 axle for output relay	≤ 5g, 11ms
Max. cable cross section	0,25 - 2,5mm ² with wire end sleeve
Terminal	Spring load clamps, pluggable
Connection wire	60/75°C copper only
Housing material	Polyamide PA unreinforced
Protection class	Installation in a closed cabinet with ≥ IP 54
Voltage at the inputs by shutdown mat	I1 to I8: 9.5 to 14V, 11.5V with 24V shutdown mat voltage
Reaction time by shutdown mat	< 20ms
Voltage at the inputs	24V DC -15%, + 10%
Input current consumption	Max. 4mA
Input voltage terminal(P) at DSV, DRV, SIV, IOV, NIV	24V DC -15% + 10%
Input current terminal(P) at DSV, DRV, SIV, IOV, NIV	≤ 4A
Input frequency at I9 – I12 at central module	≤ 1200Hz HTL-signals via as example proximity switches
Input frequency at I9 – I16 at central module	≤ 50KHz HTL-signals via incremental measuring system
Input frequency Encoder 1 and 2 at DNSL-DSV	≤ 500KHz Sin / Cos 1Vpp or TTL signals
Input frequency resolver 1 and 2 at DNSL-DRV	≤ 1200Hz Sin/ Cos 1 to 10Vpp
Input signals at DNSL-SIV	SSI interface signals
Accuracy of the analogue inputs	± 3% of the maximal input value over -10 to +60°C
Input impedance of the analogue inputs	With 4-20mA ca. 500Ω, with 0-10V > 5KΩ

Remark: current inputs (4-20mA) can be destroyed wit input voltage >12V

16.3 Technical data of the Semiconductor outputs

Technical data Semiconductor outputs	ZMV/ ZMVK		DSV, DRV		INV	IOV	NIV, SIV
Outputs	IO1 - IO4	O1 – O6	O1, O2	O3 – O7	IO1 - IO4	O1 – O7	O1 – O4
Performance level	PLe	PLe	PLc	PLe	PLe	PLe	PLd
Schematic of outputs							
Switch and continuous current Ω / L	0,1A	1A	0,25A	1A	100mA	1A	1A
Sum of Switch/continuous current Ω/L	0,4	3A	0,4A	2,5A	0,4A	3,5A	2A
Minimal Switch current Ω / L	1mA	1mA	1mA	1mA	1mA	1mA	1mA

- The power supply of the semiconductor outputs will be disconnected if the terminal A2 is not connected to 0V. Therefor residual voltage at the output loads is not possible.
- All semiconductor outputs are short circuit and overload proof.
- Every output has a recovery diode.

16.4 Technical data of the contact outputs

Technical data contact outputs	DNSL-ZMV/ ZMVK	DNSL-ZMVK	DNSL-RMV
Outputs	K1, K2	K3 – K6	K1, K2
outputs schematic, Performance level: PLe			
Minimum switch current	10mA	10mA	10mA
switch current, 0,1Hz cycles according to DIN EN 60947-4-1/ EN 60947-5-1	DC1: 24V/6A DC13: 24V/2A	DC1: 24V/6A DC13: 24V/5A	DC1: 24V/6A DC13: 24V/4A
switch current according to DIN EN 60947-4-1/ EN 60947-5-1	AC1:250V/6A AC15: 230V/3A		AC1:250V/6A AC15: 230V/3A
Sum of the switch and continuous current	K1, K2: ≤ 6A	K3, K4: ≤ 6A, K5, K6: ≤6A	K1, K2: ≤ 6A
Electrical life DC13: 24V/ 1A	1.5x10 ⁵	1x10 ⁵	9x10 ⁵
Electrical life DC13: 24V/ 4A	10 ⁴	4x10 ⁴	7x10 ⁴
Electrical life AC15: 230V/ 1A	2x10 ⁵		7x10 ⁵
Electrical life AC15: 230V/ 2A			5x10 ⁵
Mechanical life	> 50x10 ⁶	> 10 ⁷	> 40 x 10 ⁶
Maxim switch cycles DC13: 4A	360 cycles/h	360 cycles /h	360 cycles /h
Maxim switch cycles AC15: 3A	360 cycles /h		360 cycles /h
Contact fuse	6A slow	6A slow	6A slow
Short circuit strength: Automat safety fuse gG	200A/ B6 800A/ 6AgG	1000A SCPD 6A	200A/ B6 800A/ 6AgG
Rated insulation voltage	250V AC		250V AC
Impulse withstand voltage	4KV		4KV
Use in pollution degree 2 environment.			
Reaction time, drop out time	15mS/12mS	10mS/ 3mS	10mS
AC1: control of none or low inductive load, AC voltage AC15: control of electro-magnetically load, AC voltage		DC1: control of none or low inductive load, DC voltage DC13: control of electro-magnetically load, DC voltage	

16.5 Electrical life of the contact outputs

260 Work days / year/ 8h work time/ day/ switch voltage 24V DC

Modules	DNSL-ZMV, ZMVK: K1, K2					DNSL-ZMVK: K3-K6					DNSL-RMV: K1,K2					Jahre
	DC1	DC1	DC1	DC13	DC13	DC1	DC1	DC1	DC13	DC1	DC1	DC1	DC1	DC13	DC13	
Last Art	1.0A	4.0A	6.0A	1.0A	4A	1.0A	4.0A	6.0A	1.0A	4.0A	1.0A	4.0A	6.0A	1.0A	4.0A	
Schaltstrom	384	192	153	15	1	144	36	29	15	5	769	192	96	91	67	5
Schaltspiele/ Stunde	192	96	76	7	0.5	77	17	14	7	2	384	96	48	45	33	10
	96	48	38	3.6	0.25	38	8	7	3.6	1	192	48	24	23	17	20

260 Work days / year/ 8h work time/ day/ switch voltage 230V AC

Modules	DNSL-ZMV, ZMVK: K1, K2					DNSL-ZMVK: K3-K6					DNSL-RMV: K1,K2					Jahre
	AC1	AC1	AC1	AC15	AC15	AC1	AC1	AC1	AC15	AC15	AC1	AC1	AC1	AC15	AC15	
Last Art	0.5A	1.0A	3.0A	0.5A	1.0A						0.5A	1A	3.0A	0.5A	2A	
Schaltstrom	192	96	20	288	20						174	96	20	116	48	5
Schaltspiele/ Stunde	96	48	10	144	10						87	48	10	58	24	10
	48	24	5	72	5						44	24	15	28	12	20

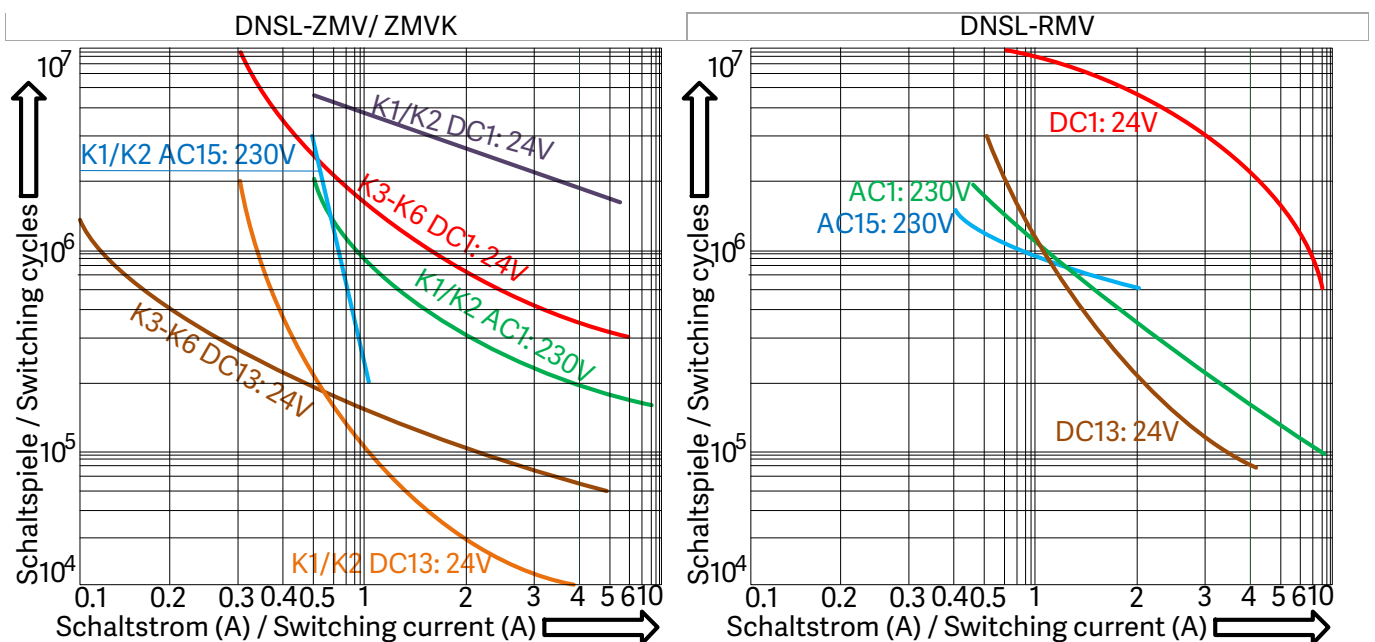

17 Dimensions

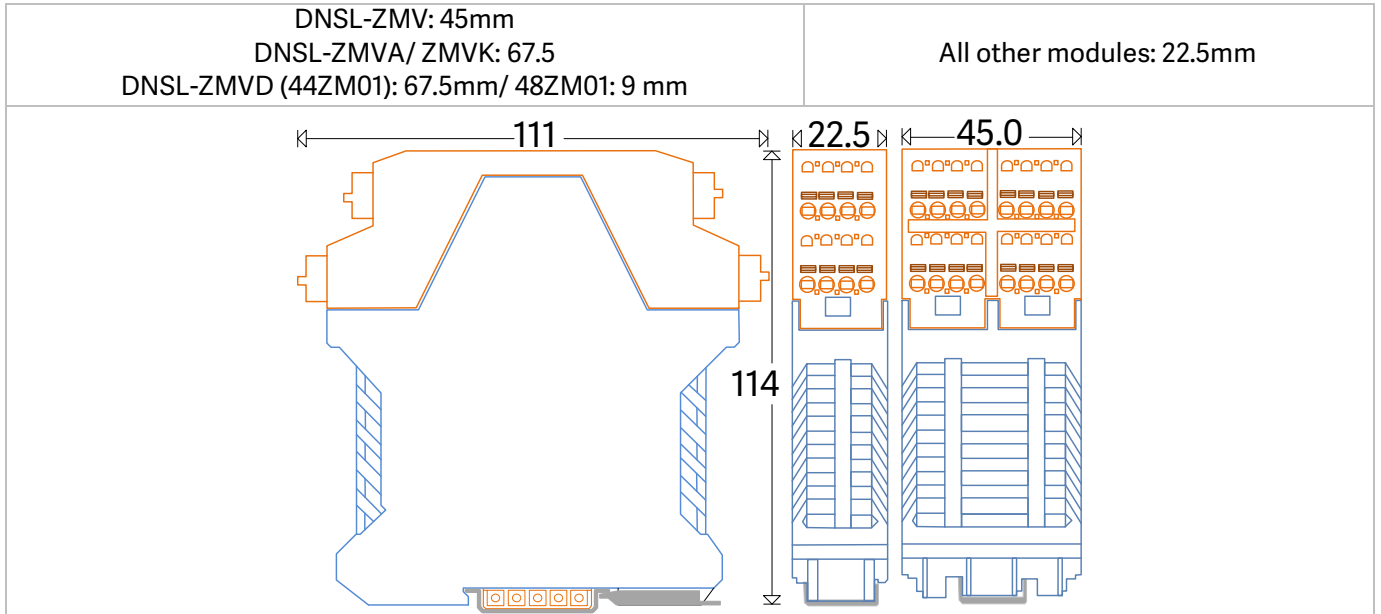

DNSL-ZMVD: 67.5 mm with 4 standstill and speed monitoring
 90.0 mm with 8 standstill and speed monitoring

17.1 Fitting and remove

<p>Fitting: Plug bus connector at the cap rail. Hook the module up side at the cap rail. Push it down.</p>	<p>Remove: Screwdriver to unlock the module from the cap rail. Move the module to the up direction and take it out.</p>
	<p style="text-align: center;">⚡ : Grounding via DIN rail</p>

- (1) Bus connector
- (2) Cap rail
- (3) Locking feeder
- (4) Cable channel