

MODEL 260 - INCREMENTAL ENCODER



Ø2.0"

FEATURES

- Low profile 1.19"
- Up to 12 pole commutation
- Available in Thru-Bore and Blind Hollow Bore
- Simple, innovative flexible mounting system
- Incorporates Opto-ASIC technology
- CE marking available

With a bore up to 0.625" and a low profile, the Model 260 Accu-Coder™ is the perfect solution for many machine and motor applications. Available in both hollow bore and a complete thru-bore, the Model 260 uses EPC's innovative anti-backlash mounting system, allowing simple, reliable, and precise encoder attachment. Unlike traditional kit or modular encoder designs, its integral bearing set provides stable and consistent operation without concerns for axial or radial shaft runout. For brushless servo motor applications, the Model 260 can be specified with three 120° electrical phase tracks to provide up to 12 pole commutation feedback. The optional extended temperature capability allows servo motors to operate at higher power outputs and duty cycles. And of course, the Model 260 uses EPC's pioneering Opto-ASIC design, so you'll always get a clean, reliable signal.

COMMON APPLICATIONS

Brushless Servo Motor Commutation, Robotics, Motor-Mounted Feedback, Assembly Machines, Digital Plotters, High Power Motors

MODEL 260 ORDERING GUIDE

Blue type indicates price adder options. Not all configuration combinations may be available. Contact Customer Service for details.

260	-	N	-	T	-	01	-	S	-	0256	-	Q	-	OC	-	1	-	S	-	SF	-	1	-	N
MODEL 260 Ultra-versatile commutated thru-bore								OPERATING TEMPERATURE³ L -40° to 70° C S 0° to 70° C H 0° to 100° C V 0° to 120° C ⁸						OUTPUT TYPE OC Open Collector PP Push-Pull HV Line Driver ⁵ OD Open Collector with Differential Outputs							SEALING 1 IP50 for Thru-Bore 2 IP64 for Thru-Bore 3 IP64 for Hollow Bore 4 IP50 for Hollow Bore			
COMMUTATION¹ N No commutation C4 4 Pole C6 6 Pole C8 8 Pole C10 10 Pole C12 12 Pole									BORE SIZE² 01 1/4", 0.250" 02 3/8", 0.375" 76 7/16", 0.4375" 10 1/2", 0.500" 11 5/8", 0.625" 06 5 mm 04 6 mm 14 8 mm 05 10 mm 09 11 mm 12 12 mm 13 14 mm 15 15 mm	CYCLES PER REVOLUTION 1-10,000 See CPR Options below Price adder for >1999				MAXIMUM FREQUENCY 1 Standard 2 Extended See Specifications for explanation.				MOUNTING SD 1.575" (40 mm) BC Flex Mount SF 1.811" (46 mm) BC Flex-Mount SL 2.36" (60 mm) BC Flex Mount XF 2.250" BC 3-point Flex Mount NF 2.375" BC 3-point Flex Mount FA 2.12" to 3.62" BC Flex Arm FB 3.00" to 6.26" BC Flex Arm						
HOUSING STYLE B Blind hollow bore T Front clamp thru-bore R Rear clamp thru-bore										NUMBER OF CHANNELS⁴ Channel A Leads B Q Quadrature A & B R Quadrature A & B with Index Channel B Leads A K Reverse Quadrature A & B D Reverse Quadrature A & B with Index See Quadrature Phasing and Index Gating Options for additional options and waveforms at encoder.com				CONNECTOR TYPE⁶ S 18" Cable ⁷ J00 18" Cable with 5-pin M12 ⁸ K00 18" Cable with 8-pin M12 ⁸ SMJ 5-pin Body Mount M12 ^{5,9} SMK 8-pin Body Mount M12 standard wiring ⁹ SMZ 8-pin Body Mount M12 optional wiring ⁹ SMH 10-pin Body Mount Bayonet ⁹				CERTIFICATION N None (Std) CE CE Marked ¹⁰						

NOTES:

- Not available in all configurations. Contact Customer Service for availability.
- Contact Customer Service for additional options not shown.
- 5 to 16 VDC supply only for H option; 5 VDC supply only for V option. Contact Customer Service for availability and additional information.
- Contact Customer Service for non-standard index gating options.
- Line Driver not available with 5-pin Body Mount M12 connector type.
- For mating connectors, cables, and cordsets see Accessories at encoder.com. For Connector Pin Configuration Diagrams, see Technical Information or see Connector Pin Configuration Diagrams at encoder.com.
- For non-standard cable lengths add a forward slash (/) plus cable length expressed in feet. Example: S/6 = 6 feet of cable. Frequency above 300 kHz standard cable lengths only.
- M12 Connector Type not available with commutation or with V temperature option. Additional cable lengths available. Please consult Customer Service.
- Not available with commutation.
- Please refer to Technical Bulletin TB-100: When to Choose the CE Mark at encoder.com.

Model 260 CPR Options

0001 thru 0189*	0198	0200	0250	0254	0256	0300
0360	0400*	0500	0512	0600	0720	1000
1024	1200	1250	1270	1500	1800	2000
2500	2540	3000	3600	4000	4096	5000
7200	8192	10,000				6000

*Contact Customer Service for availability. New CPR values are periodically added to those listed. Contact Customer Service to determine all currently available values. Special disk resolutions are available upon request and may be subject to a one-time NRE fee.

MODEL 260 - INCREMENTAL ENCODER

MODEL 260 SPECIFICATIONS

Electrical

Input Voltage.....	4.75 to 28 VDC for temperatures up to 70° C 5 to 16 VDC for 0° to 100° C operating temperature 5 VDC for 0° to 120° C operating temperature
Input Current.....	130 mA max (< 100 mA typical) with no output load
Output Format	Incremental – Two square waves in quadrature with channel A leading B for clockwise shaft rotation, as viewed from the mounting face. See Waveform Diagrams.
Output Types	Open Collector – 20 mA max per channel Push-Pull – 20 mA max per channel Line Driver – 20 mA max per channel (Meets RS 422 at 5 VDC supply)
Index.....	Once per revolution gated to channel A. See Waveform Diagrams.
Max. Frequency.....	Standard Frequency Response is 200 kHz for CPR 1 to 2540 500 kHz for CPR 2541 to 5000 1 MHz for CPR 5001 to 10,000 Extended Frequency Response (optional) is 300 kHz for CPR 2000, 2048, 2500, and 2540
Electrical Protection.....	Reverse voltage and output short circuit protected. NOTE: Sustained reverse voltage may result in permanent damage.
Noise Immunity	Tested to BS EN61000-6-2; BS EN50081-2; BS EN61000-4-2; BS EN61000-4-3; BS EN61000-4-6, BS EN55011
Quadrature Edge Separation.....	67.5° electrical or better is typical, 54° electrical minimum at temperatures > 99° C
Accuracy.....	Within 0.01° mechanical from one cycle to any other cycle, or 0.6 arc minutes.
Commutation	Up to 12 pole. Contact Customer Service for availability.
Comm. Accuracy.....	1° mechanical.

Mechanical

Max Shaft Speed.....	7500 RPM. Higher shaft speeds may be achievable, contact Customer Service. Note: For extreme temperature operation, de-rate temperature by 5° C for every 1000 RPM above 3000 RPM.
Bore Tolerance.....	-0.0000" / +0.0006"
User Shaft Tolerances	
Radial Runout.....	0.007" max
Axial Endplay.....	±0.030" max
Starting Torque	IP50 Thru-Bore: 0.50 oz-in IP50 Hollow Bore: 0.30 oz-in IP64 Thru-Bore: 2.50 oz-in IP64 Hollow Bore: 2.0 oz-in Note: Add 3.0 oz-in for -40° C operation
Moment of Inertia.....	3.9 x 10 ⁻⁴ oz-in-sec ²
Housing.....	Non-corrosive material
Weight.....	3.5 oz typical

Environmental

Storage Temp.....	-40° to 100° C
Humidity.....	98% RH non-condensing
Vibration	10 g @ 58 to 500 Hz
Shock.....	50 g @ 11 ms duration
Sealing.....	IP50; IP64 available

MODEL 260 WITH FRONT SHAFT CLAMP (T)

With 1.811" (46 mm) BC Slotted Flex (SF)

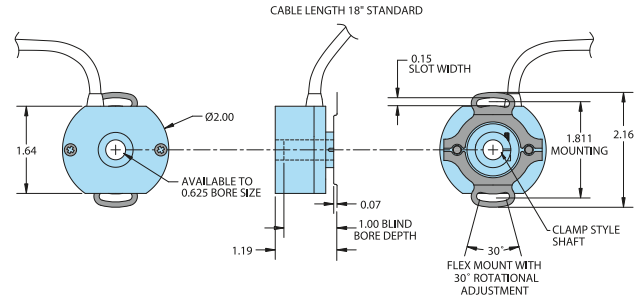

MODEL 260 REAR CLAMP (R)

With 1.811" (46 mm) BC Slotted Flex (SF)

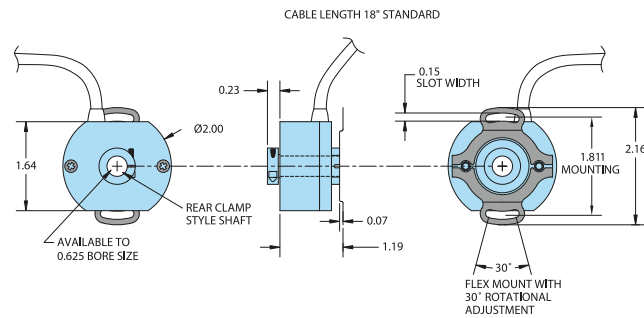

THREE POINT FLEX MOUNT (XF, NF)

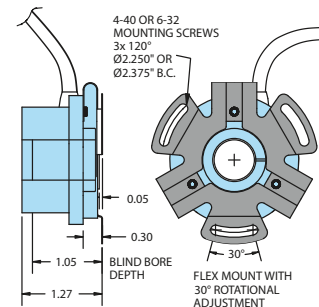

1.575" (40 MM) BC FLEX MOUNT (SD)

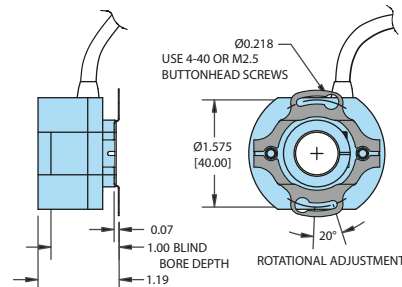

All dimensions are in inches with a tolerance of ±0.005" or ±0.01" unless otherwise specified.

MODEL 260 - INCREMENTAL ENCODER

1.06" TO 1.81" FLEX ARM (FA)

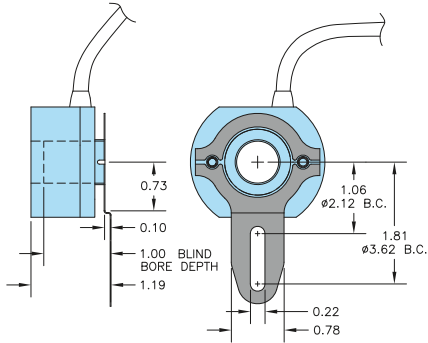

2.36" (60 MM) BC FLEX MOUNT (SL)

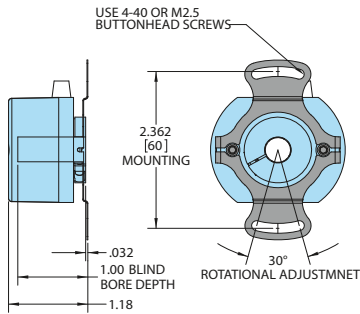

1.50" TO 3.13" FLEX ARM (FB)

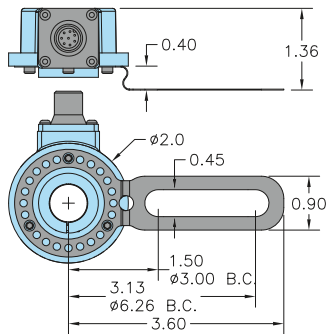

MODEL 260 CONNECTOR OPTIONS

Body Mount 10-Pin Bayonet (SMH)

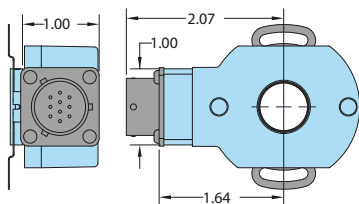

Body Mount M12 (SMJ, SMK)

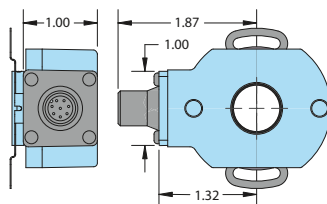

All dimensions are in inches with a tolerance of $\pm 0.005"$ or $\pm 0.01"$ unless otherwise specified.

MODEL 260 - INCREMENTAL ENCODER

WAVEFORM DIAGRAMS

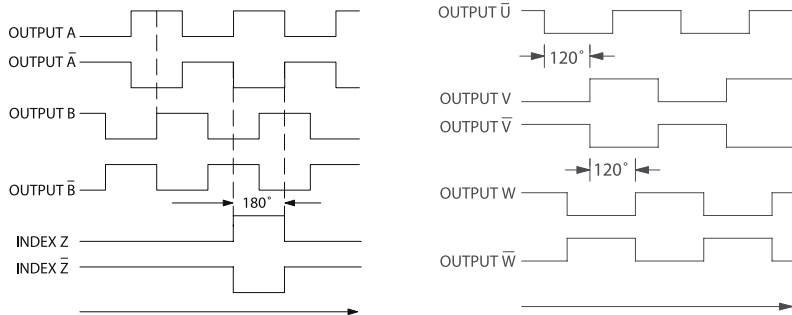

CLOCKWISE ROTATION AS VIEWED FROM THE MOUNTING FACE

NOTE: ALL DEGREE REFERENCES ARE ELECTRICAL DEGREES. Waveform shown with optional complementary signals \bar{A} , \bar{B} , \bar{Z} for HV and OD outputs only.

WIRING TABLE

For EPC-supplied mating cables, refer to wiring table provided with cable. Trim back and insulate unused wires.

Function	Flying Leads Cable† Wire Color	5-pin M12**	8-pin M12** standard wiring	8-pin M12** optional wiring	10-pin Bayonet‡
Com	Black	3	7	1	F
+VDC	White	1	2	2	D
A	Brown	4	1	3	A
A'	Yellow	--	3	4	H
B	Red	2	4	5	B
B'	Green	--	5	6	J
Z	Orange	5	6	7	C
Z'	Blue	--	8	8	K
U	Violet	--	--	--	--
U'	Gray	--	--	--	--
V	Pink	--	--	--	--
V'	Tan	--	--	--	--
W	Red/Green	--	--	--	--
W'	Red/Yellow	--	--	--	--
Shield	Bare*	--	--	--	--

†Standard cable for non-commutated models is 24 AWG. For commutated units, conductors are 28 AWG.

*CE Option: Cable shield (bare wire) is connected to internal case.

**CE Option: Use cable cordset with shield connected to M12 connector coupling nut.

‡CE Option: Pin G is connected to internal case.